

SmartHandle AX

Manual

27.07.2021

Simons  Voss
technologies

Contents

1	Intended use	5
2	General	6
3	General safety instructions.....	8
4	Product-specific safety instructions.....	11
5	Meaning of the text formatting	12
6	Versions.....	13
6.1	Mechanical Override (MO).....	13
6.2	Profiles.....	13
6.3	Fastening.....	13
6.4	Distances and door thicknesses.....	14
6.5	PAS24.....	15
6.6	SmartHandle AX without electronics.....	15
6.7	Spindle	15
6.8	Network	16
6.9	Handle variants.....	16
6.10	Surface finishes.....	17
6.11	Reader technology.....	18
6.12	Access control (ZK) and time zone control.....	18
7	Installation	20
7.1	Installation instructions.....	20
7.2	Variant A0 (vertical installation).....	21
7.2.1	Contents of packaging.....	21
7.2.2	Tools.....	22
7.2.3	Procedure.....	23
7.3	Variants A1 and A2 (suspended mounting)	44
7.3.1	Contents of packaging.....	44
7.3.2	Tools.....	45
7.3.3	Procedure.....	46
7.3.4	Glass door fitting.....	63
7.4	Variant A3 (steel frame)	64
7.4.1	Contents of packaging.....	64
7.4.2	Tools.....	65
7.4.3	Procedure.....	66
7.5	Variant A4 (Panic bar)	79
7.5.1	Package contents (BKS).....	79

7.5.2	Package contents (CISA)	81
7.5.3	Tools.....	81
7.5.4	Procedure (BKS)	83
7.5.5	Procedure (CISA).....	97
7.5.6	Information for panic bar.....	109
7.6	DS variant (reader on both sides)	109
7.6.1	Contents of packaging.....	109
7.6.2	Tool.....	110
7.6.3	Procedure.....	111
7.7	Variants E0 and E1 (Scandinavian Oval)	127
7.7.1	Contents of packaging.....	128
7.7.2	Tools.....	129
7.7.3	Procedure.....	129
7.8	LockNode (LNI)	145
7.8.1	Contents of packaging.....	145
7.8.2	Tools.....	145
7.8.3	Procedure.....	146
8	Programming.....	154
9	Configuration.....	155
9.1	Pulse length	155
9.2	Access control	155
9.3	Time zone control.....	155
9.4	Logging unauthorised attempted access events.....	156
9.5	Flip flop	156
9.6	Close range mode.....	157
9.7	Time switch-over function	157
9.8	Ignore activation or expiry date.....	158
9.9	No audible programming feedback signals.....	159
9.10	Card interface	159
9.11	Extended configuration.....	159
9.11.1	Time-controlled changeover.....	159
9.11.2	Turn off LED/beeper.....	160
10	Operation.....	162
11	Status messages.....	163
11.1	Battery status feedback	163
11.2	Emergency release.....	163
11.3	Deactivated	163
11.4	Engaged.....	163

11.5	Possible DoorMonitoring states of SmartHandle AX.....	163
12	Signal	164
13	Battery warning	165
13.1	Warning level	165
14	Battery replacement.....	166
14.1	Instructions on battery replacement.....	166
14.2	Procedure	166
15	Maintenance, cleaning and disinfection.....	169
16	Disassembly.....	170
16.1	Variant A0 (vertical).....	170
16.2	Variant A1/A2 (suspended short/long).....	171
16.3	Variant A3 (steel frame)	173
16.4	Variant A4 (Panic bar)	174
16.4.1	BKS.....	174
16.4.2	CISA.....	176
16.5	DS variant (reader on both sides)	177
16.6	Variant E0 and E1 (Scandinavian Oval).....	179
17	Accessories	181
18	Technical specifications	185
18.1	Electronics	185
18.2	Mechanical system	186
18.2.1	Dimensional drawings SmartHandle AX.....	190
18.2.2	Dimensional drawings handles	196
18.3	Configuration.....	197
19	EU/UK Declaration of conformity.....	198
20	Help and other information	199

1 Intended use

Products in the SmartHandle AX range consist of electronic door fittings. Users can engage SmartHandle AX and open the door onto which it is fitted with an authorised ID medium, such as a transponder.

The corresponding authorisations need to be issued using an electronic locking plan.

Products in the SmartHandle AX range may only be used for locking and unlocking doors. No other use is permitted.

2 General

The SmartHandle AX is an electronic fitting that can be used to open and close a door.

Electronic fittings in the this range are available in the following models (also see *Versions* [▶ 13]):

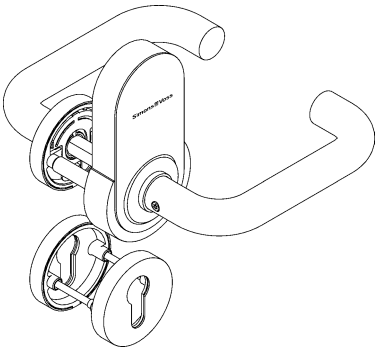
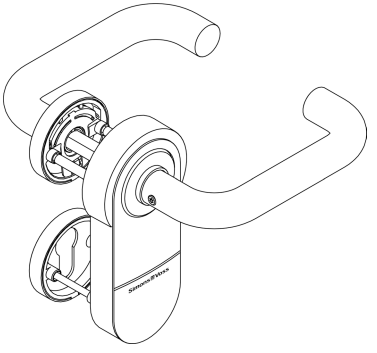
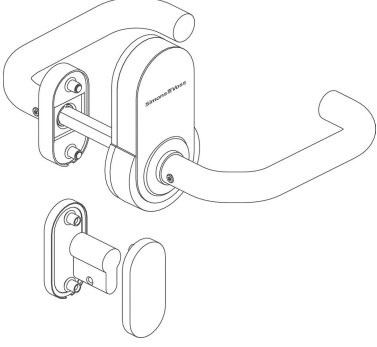
Digital SmartHandle AX	Description
<p data-bbox="119 600 327 633">Variant A0/B0</p> 	<ul style="list-style-type: none"> <li data-bbox="582 600 1310 674">■ Electronic door handle for mounting on prepared escutcheon holes for stationary installation <li data-bbox="582 696 1302 770">■ Suitable for handle locks with Euro profile (A) or SwissRound (B) <li data-bbox="582 792 1358 826">■ Outer side operated with identification medium only <li data-bbox="582 848 1193 882">■ Inner side permanently engaged to open <li data-bbox="582 904 1134 938">■ Optional: Mechanical Override (MO) <li data-bbox="582 960 932 994">■ Optional: FH approval
<p data-bbox="119 1039 432 1072">Variants A1/ A1, B1/ A2</p> 	<ul style="list-style-type: none"> <li data-bbox="582 1039 1310 1113">■ Electronic door handle for mounting on prepared escutcheon holes for suspended installation <li data-bbox="582 1135 1302 1209">■ Suitable for handle locks with Euro profile (A) or SwissRound (B) <li data-bbox="582 1232 1358 1265">■ Outer side operated with identification medium only <li data-bbox="582 1288 1193 1321">■ Inner side permanently engaged to open <li data-bbox="582 1344 932 1377">■ Optional: FH approval <li data-bbox="582 1400 1034 1433">■ Optional: PAS24 certification
<p data-bbox="119 1473 268 1507">Variant A3</p> 	<ul style="list-style-type: none"> <li data-bbox="582 1473 1401 1547">■ Electronic door handle for mounting on prepared metal frame doors <li data-bbox="582 1570 1235 1603">■ Suitable for handle locks with a Euro Profile <li data-bbox="582 1626 1358 1659">■ Outer side operated with identification medium only <li data-bbox="582 1682 1193 1715">■ Inner side permanently engaged to open <li data-bbox="582 1738 1134 1771">■ Optional: Mechanical Override (MO) <li data-bbox="582 1794 932 1827">■ Optional: FH approval

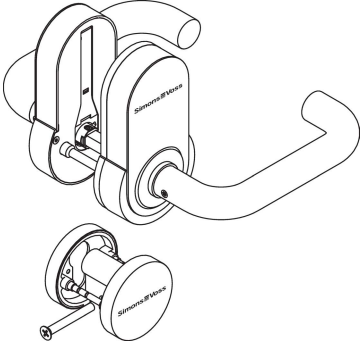
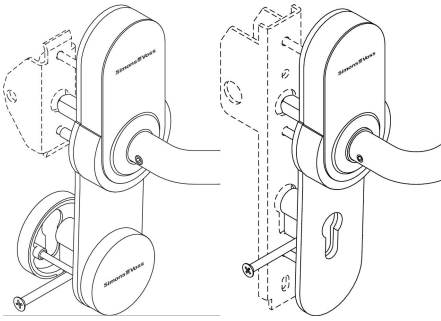
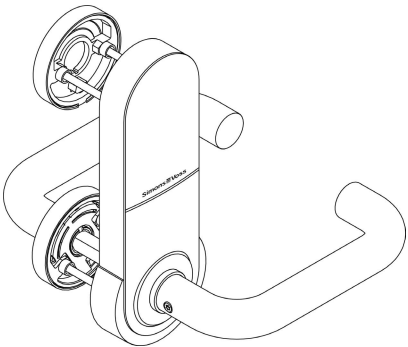
Digital SmartHandle AX	Description
<p>DS version</p> 	<ul style="list-style-type: none"> ■ Electronic door handle for mounting on prepared escutcheon holes for stationary installation ■ Suitable for handle locks with Euro profile (A) or SwissRound (B) ■ Outside and inside can only be operated with identification medium ■ Optional: Mechanical Override (MO)
<p>Variant A4</p> 	<ul style="list-style-type: none"> ■ Electronic door handle for stationary installation with panic bar adaptation ■ Suitable for handle locks with a Euro Profile ■ Outer side operated with identification medium only ■ Inner side permanently engaged to open ■ Optional: Mechanical Override (MO) ■ Optional: FH approval
<p>Variants E0, E1</p> 	<ul style="list-style-type: none"> ■ Electronic door handle for mounting on predrilled holes for Scandinavian Oval ■ Outer side operated with identification medium only ■ Inner side permanently engaged to open ■ Optional: Mechanical Override (MO) ■ Optional: FH approval

3 General safety instructions

Signal word (ANSI Z535.6)	Possible immediate effects of non-compliance
DANGER	Death or serious injury (likely)
WARNING	Death or serious injury (possible, but unlikely)
CAUTION	Minor injury
IMPORTANT	Property damage or malfunction
NOTE	Low or none



WARNING

Blocked access

Access through a door may stay blocked due to incorrectly fitted and/or incorrectly programmed components. SimonsVoss Technologies GmbH is not liable for the consequences of blocked access such as access to injured or endangered persons, material damage or other damage!

Blocked access through manipulation of the product

If you change the product on your own, malfunctions can occur and access through a door can be blocked.

- Modify the product only when needed and only in the manner described in the documentation.

Do not swallow battery. Danger of burns from hazardous substances

This product contains lithium button cell batteries. Swallowing the button cell battery, in can result in severe internal burns leading to death in as little as two hours.

1. Keep new and used batteries away from children.
2. If the battery compartment does not close securely, cease using the product and keep it away from children.
3. If you think batteries have been swallowed or are in any part of the body, seek medical attention immediately.

Risk of explosion due to incorrect battery type

Inserting the wrong type of battery can cause an explosion.

- Only use the batteries specified in the technical data.

**CAUTION****Fire hazard posed by batteries**

The batteries used may pose a fire or burn hazard if handled incorrectly.

1. Do not try to charge, open, heat or burn the batteries.
2. Do not short-circuit the batteries.

IMPORTANT**Damage resulting from electrostatic discharge (ESD)**

This product contains electronic components that may be damaged by electrostatic discharges.

1. Use ESD-compliant working materials (e.g. Grounding strap).
2. Ground yourself before carrying out any work that could bring you into contact with the electronics. For this purpose, touch earthed metallic surfaces (e.g. door frames, water pipes or heating valves).

Damage resulting from liquids

This product contains electronic components that may be damaged by liquids of any kind.

- ❑ Keep liquids away from the electronics.

Damage resulting from aggressive cleaning agents

The surface of this product may be damaged as a result of the use of unsuitable cleaning agents.

- ❑ Only use cleaning agents that are suitable for plastic or metal surfaces.

Damage as a result of mechanical impact

This product contains electronic components that may be damaged by mechanical impacts of any kind.

1. Avoid touching the electronics.
2. Avoid other mechanical influences on the electronics.

Damage due to polarity reversal

This product contains electronic components that may be damaged by reverse polarity of the power source.

- ❑ Do not reverse the polarity of the voltage source (batteries or mains adapters).

Operational malfunction due to radio interference

This product may be affected by electromagnetic or magnetic interference.

- ❑ Do not mount or place the product directly next to devices that could cause electromagnetic or magnetic interference (switching power supplies!).

Communication interference due to metallic surfaces

This product communicates wirelessly. Metallic surfaces can greatly reduce the range of the product.

- ❑ Do not mount or place the product on or near metallic surfaces.



NOTE

Intended use

SimonsVoss-products are designed exclusively for opening and closing doors and similar objects.

- ❑ Do not use SimonsVoss products for any other purposes.

Malfunctions due to poor contact or different discharge

Contact surfaces that are too small/contaminated or different discharged batteries can lead to malfunctions.

1. Only use batteries that are approved by SimonsVoss.
2. Do not touch the contacts of the new batteries with your hands.
3. Use clean and grease-free gloves.
4. Always replace all batteries at the same time.

Different times for G2 locks

The internal time unit of the G2 locks has a technical tolerance of up to ± 15 minutes per year.

Qualifications required

The installation and commissioning requires specialized knowledge.

- ❑ Only trained personnel may install and commission the product.

Incorrect installation

SimonsVoss Technologies GmbH accepts no liability for damage caused to doors or components due to incorrect fitting or installation.

Modifications or further technical developments cannot be excluded and may be implemented without notice.

The German language version is the original instruction manual. Other languages (drafting in the contract language) are translations of the original instructions.

Read and follow all installation, installation, and commissioning instructions. Pass these instructions and any maintenance instructions to the user.

4 Product-specific safety instructions

IMPORTANT

Damage by drilling

You drill at your own risk. SimonsVoss Technologies GmbH is not liable for damage caused by drilling.

- ❑ Please also observe the safety instructions of the drilling machine.

Damage caused by unsuitable tools

If you try to open the case with unsuitable tools, the case may be damaged.

- ❑ Use only the supplied SimonsVoss opening tool.



NOTE

Effect on the mortise lock

The SmartHandle AX acts exclusively on the latch of the mortise lock.

Locking and insurances

Insurance companies place increased demands on a closure.

1. If you want to lock the door under insurance law, use a self-locking panic lock or a locking cylinder in addition to the SmartHandle AX.
2. Pay attention to the approvals according to EN 179.

SmartHandle AX with self-locking panic lock

The SmartHandle AX only offers full functionality with a self-locking panic lock.

1. Combine the SmartHandle AX with a self-locking panic lock.
2. Pay attention to the declarations of conformity of the lock manufacturers according to EN 179.

5 Meaning of the text formatting

This documentation uses text formatting and design elements to facilitate understanding. The table explains the meaning of possible text formatting:

Example	button
<input checked="" type="checkbox"/> Example	checkbox
<input type="checkbox"/> Example	
<input checked="" type="radio"/> Example	Option
[Example]	Tab
"Example"	Name of a displayed window
Example	Upper programme bar
Example	Entry in the expanded upper programme bar
Example	Context menu entry
▼ Example	Name of a drop-down menu
"Example"	Selection option in a drop-down menu
"Example"	Area
Example	Field
<i>Example</i>	Name of a (Windows) service
<i>Example</i>	Commands (e.g. Windows CMD commands)
Example	Database entry
[Example]	MobileKey type selection

6 Versions

6.1 Mechanical Override (MO)

You can also install a mechanical locking cylinder (see *Profiles* [▶ 13]).

This enables you to open the door without using the electronics and open the door with a mechanical key.

This allows you to set up a mechanical fire brigade lock for rescue services.

Order according to your aesthetic needs:

- Cut-out for the cylinder open on both sides
- Cut-out for the cylinder open on one side
- Cut-out for the cylinder concealed on both sides (completely concealed and invisible cylinder)

6.2 Profiles

Choose from the following mortise lock profiles for your SmartHandle AX:

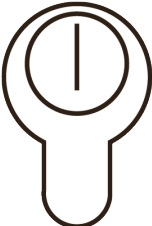
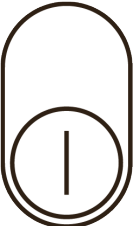
Euro profile cylinder	Swiss Round	Scandinavian Oval
		

6.3 Fastening

You can use the following fastening types:

Fastening		
Escutcheon fastening with (optional) mechanical over-locking	<ul style="list-style-type: none"> ■ <i>Variant A0 (vertical installation) [▶ 21]</i> ■ <i>Variants A1 and A2 (suspended mounting) [▶ 44]</i> ■ <i>DS variant (reader on both sides) [▶ 109]</i> ■ <i>Variants E0 and E1 (Scandinavian Oval) [▶ 127]</i> 	You fix the SmartHandle AX with drill holes and holes in the mortise lock.

Fastening		
Mortise frame fastening with (optional) mechanical overlocking	<i>Variant A3 (steel frame) [▶ 64]</i>	You fix the SmartHandle AX on adapter plates. These adapter plates are screwed to the metal frame using rivet nuts.
Escutcheon fastening with panic bar adapter	<i>Variant A4 (Panic bar) [▶ 79]</i>	You fix the SmartHandle AX by means of adapter plates through drilled holes and holes in the mortise lock. On the inside, you can then mount a panic bar, which must be ordered separately.

6.4 Distances and door thicknesses

A* = Euro profile, B* = Swiss round, E* = Scandinavian Oval

Versions	Centres distance	Door thickness
A0/B0 Stationary	not relevant (stationary installation: Handle shaft axis and profile cylinder axis not connected at the fitting)	S: 38 - 60 mm
		M: 59 - 80 mm
		L: 79 - 100 mm
		X: 100-200 mm
A1/B1 Suspended, short	70 - 79 mm	S: 38 - 60 mm
		M: 59 - 80 mm
		L: 79 - 100 mm
		X: 100-200 mm
A2/B2 Suspended, long	70 - 110 mm	S: 38 - 60 mm
		M: 59 - 80 mm
		L: 79 - 100 mm
		X: 100-200 mm
A3 Metal frames	not relevant (stationary installation: Handle shaft axis and profile cylinder axis not connected at the fitting)	S: 38 - 57 mm
		M: 58 - 77 mm
		L: 78 - 97 mm
		X: 97 - 196 mm

Versions	Centres distance	Door thickness
A4 Panic bar	92 mm (BKS full-leaf door without plate) 72 mm (CISA full-leaf door, with plate or BKS full-leaf door without sign)	S: 38 - 60 mm
		M: 59 - 80 mm
		L: 79 - 100 mm
		X: 100–200 mm
DS Reader on both sides (double-sided)	not relevant (stationary installation: Handle shaft axis and profile cylinder axis not connected at the fitting)	S: 38 - 58 mm
		M: 59 - 78 mm
		L: 79 - 99 mm
		X: 100–200 mm
E0, E1 Scandinavian Oval	105 mm	S: 38 - 60 mm
		M: 59 - 80 mm
		L: 79 - 100 mm
		X: 100–200 mm

6.5 PAS24

SmartHandle AX is also available with PAS24 certification (see <https://www.simons-voss.com/de/zertifikate.html>)

This version also meets the highest security requirements, guarantees sustainable functionality even in extreme situations and provides optimum protection against break-ins or attempted manipulation.

6.6 SmartHandle AX without electronics

SmartHandle AX is also available (for example for design purposes) without electronics. The square is then always continuous and the door can therefore be operated from both sides without an identification medium.

If you want to lock the door, you need a variant with mechanical override (MO). Here you can lock the door with an additional cylinder (see *Profiles* [▶ 13]).

6.7 Spindle

You can use the following square sizes:

Square size	
7 mm	
8 mm	

Square size	
8.5 mm	<ul style="list-style-type: none">■ with sleeve attached to 8 mm (not included in delivery)■ sold separately
9 mm	Order the fire-retardant version of the SmartHandle AX or fire doors and emergency exit locks.
10 mm	With sleeve attached to 8 mm (already included in the scope of delivery for ordered 10 mm version of the SmartHandle AX)

6.8 Network

You can equip the SmartHandle AX with a network node at any time (see *LockNode (LNI)* [▶ 145]). You do not need to exchange components to do this. Instead, you simply plug the board of the network node into the slot provided.

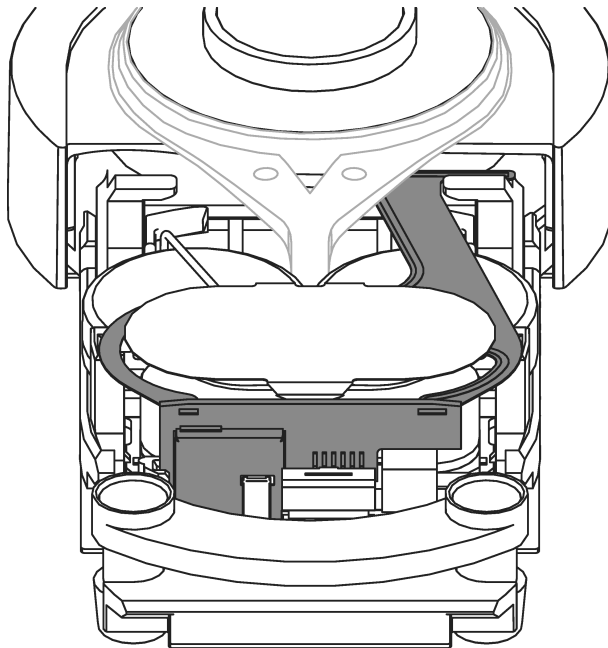

6.9 Handle variants

You can personalise your SmartHandle AX with the following handle variants:

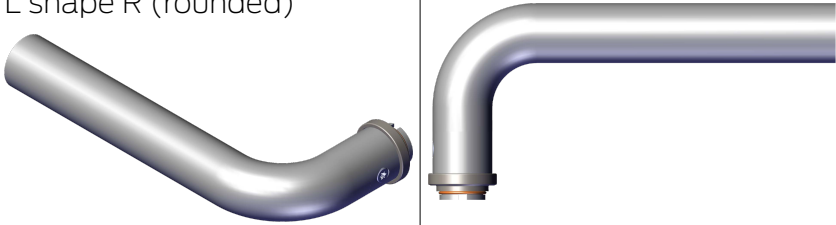
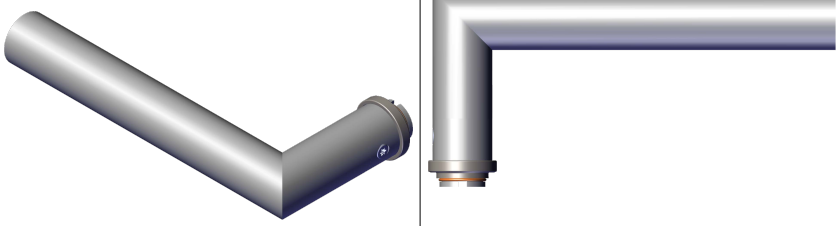
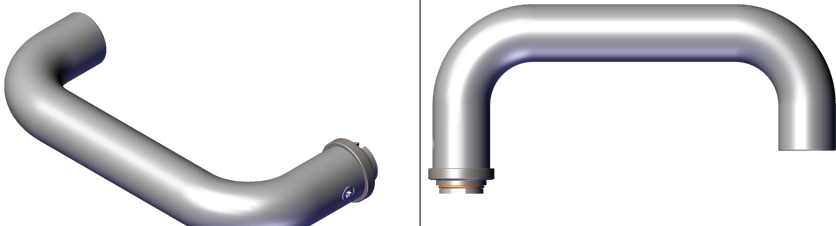
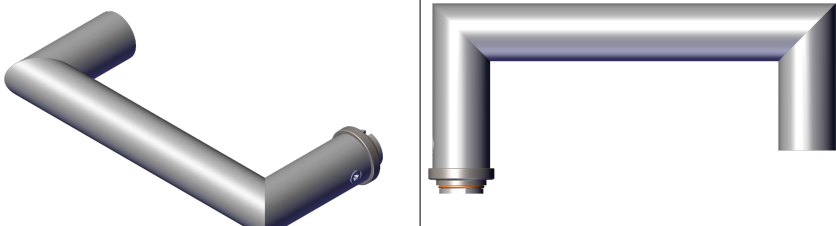
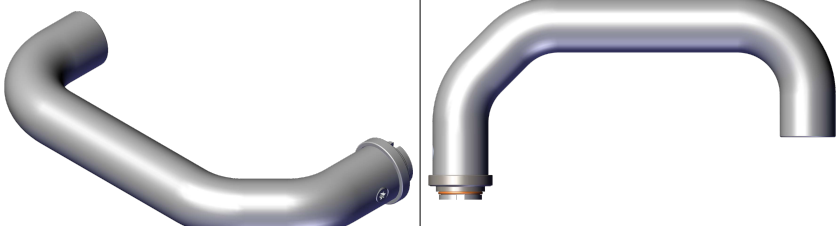
Letter	Description	
A	L shape R (rounded)	
B	L shape G (mitred)	
C	U shape R (rounded)	
D	U shape G (mitred)	
L	U shape (round and offset)	
O	Supplied without handle (for use with adapter sets and third-party handles, see Accessories [▶ 181])	

6.10 Surface finishes

Select the upper surface for your SmartHandle AX:



6.11 Reader technology

Depending on the product features, your SmartHandle AX supports the following reading methods:

- Active (25 kHz) - initial programming also possible passively
- Passive (MIFARE Classic, Plus, DESFire)
- Hybrid (active and passive in one SmartHandle AX)
- BLE (Bluetooth Low Energy. SmartHandle AX is prepared and can be retrofitted after release)

The 2L variant is a special version of the stationary SmartHandle AX, which can be combined with an additional stationary SmartHandle AX to form a fitting that reads from both sides.

Alternatively, the SmartHandle AX is also available without electronics or permanently coupled.

6.12 Access control (ZK) and time zone control

Access Control

With this option, your SmartHandle AX can store up to 1500 accesses.

A saved entry consists of:

- Date
- Time
- Transponder ID (TID)

You can read this data at any time with a programming device or via the network and thus trace which transponder was used when to operate the SmartHandle AX.

Time zone control

In addition, the time zone option also allows you to control the time zone. You can then program your SmartHandle AX in such a way that certain identification media are only authorised for access at certain times. You

can create up to 64000 different time zone plans in each G2 locking system or 100+1 time zone groups in each G2 lock. For detailed information on time zone control, see the LSM manual.

7 Installation

You can programme the SmartHandle AX while it is still in the packaging (except MP) and then install it.

You will also find information on installing the SmartHandle AX in the accompanying quick guide.

7.1 Installation instructions

- The batteries are already fitted.
- Do not touch electronics/components; do not allow them to come into contact with oil, paint, moisture, alkali or acids.
- Keep away from sources of interference, such as power supply units.
- You must not strike the product while installing the cylinder.
- Attach plan to the door. Do not install while bent or tensioned.
- Use the supplied drilling template.
- If required, fit the supplied dummy cylinder to comply with approval requirements for FH variants.
- Only undo the indicated screws.

7.2 Variant A0 (vertical installation)

7.2.1 Contents of packaging

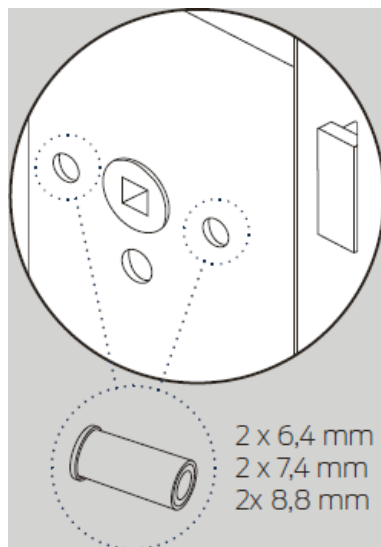
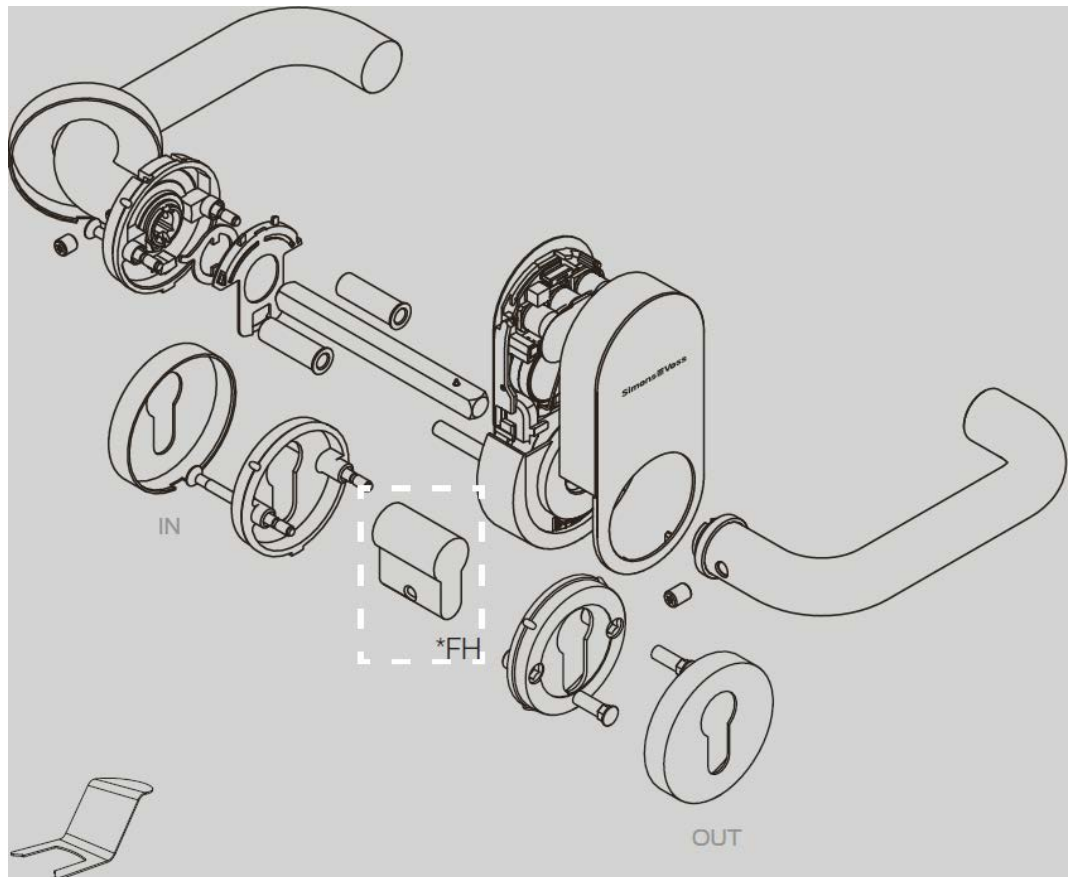

Quantity	Object	
1x	External fitting assembly, incl:	
	4x	Battery (CR2450)
	1x	Inlay

Quantity	Object
1×	Exterior handle, incl:
	1× Headless screw
1×	Interior handle, incl:
	1× Headless screw
	1× pre-assembled escutcheon base
1×	Exchangeable plate
1×	Spring element
2×	Escutcheon base for cylinder opening
1×	Escutcheon cover for interior handle
2×	Escutcheon cover for cylinder opening
4×	Screw with predetermined breaking points
2×	Sleeve nuts for escutcheon base
2×	Adapter sleeve 6.4 mm
2×	Adapter sleeve 7.4 mm
2×	Adapter sleeve 8.8 mm
1×	Spindle
1×	Installation tool
1×	Dummy cylinder (FH version only)
1×	Quick guide with integrated drilling template

7.2.2 Tools

You require the following tools for installation:

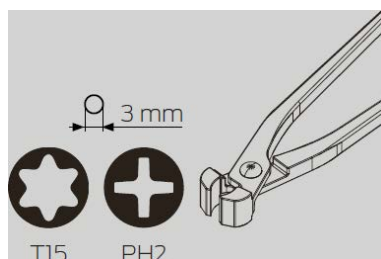

- TX-15 screwdriver
- PH2 screwdriver
- Suitable pliers for shortening screws, e.g. mechanic's nippers
- (X-variant: Saw for shortening square, e.g. hacksaw)

7.2.3 Procedure

Preparing drill holes

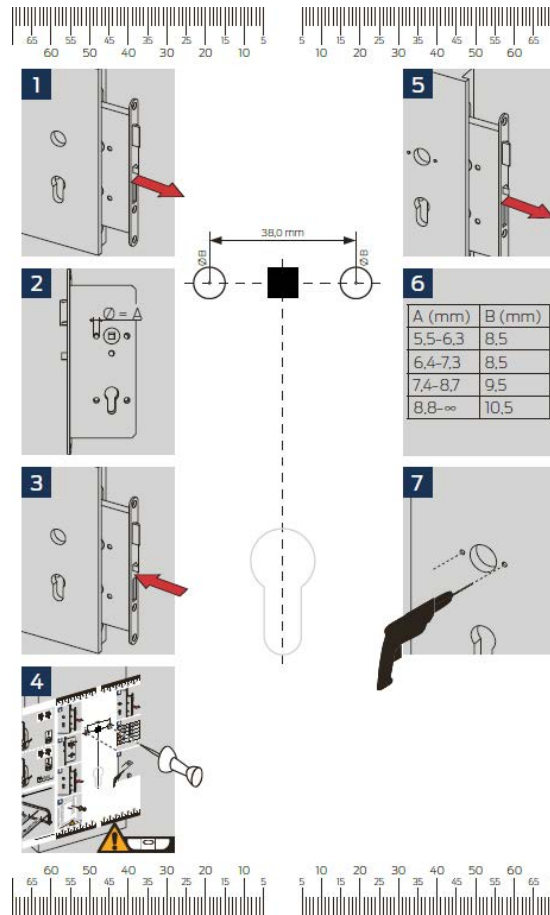

Diameter A	Drill B
5.5 - 6.3 mm	8.5 mm
6.4 - 7.3 mm	8.5 mm
7.4 - 8.7 mm	9.5 mm
8.8 or larger	10.5 mm

1. Pull out the mortise lock.



2. Measure the diameter of the fixing holes on the mortise lock.

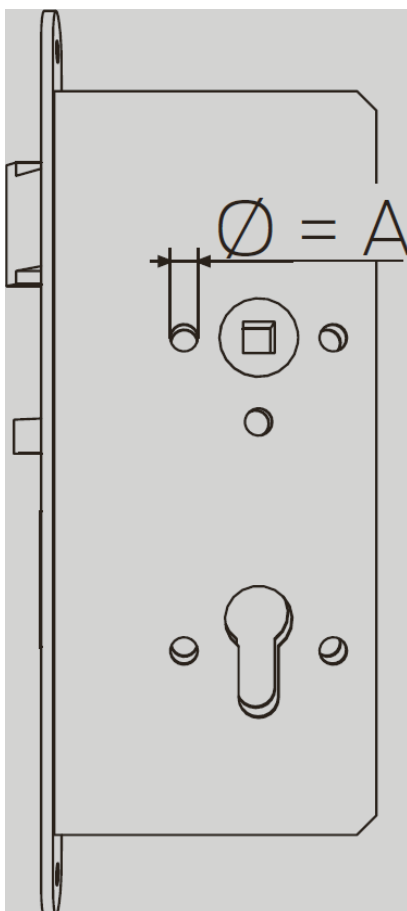

3. Slide the mortise lock back into the door.



4. Insert the square into the mortise lock.
5. Using the square and the recess in the drilling template, position the drilling template on the door.

IMPORTANT

Horizontal alignment required

The drill holes must be aligned horizontally.

- Use the printed scale to ensure that the drilling template is aligned horizontally (equal distances).
-

6. Use a pointed object (e.g. pin needle) to pierce the position of the drill holes in the door.

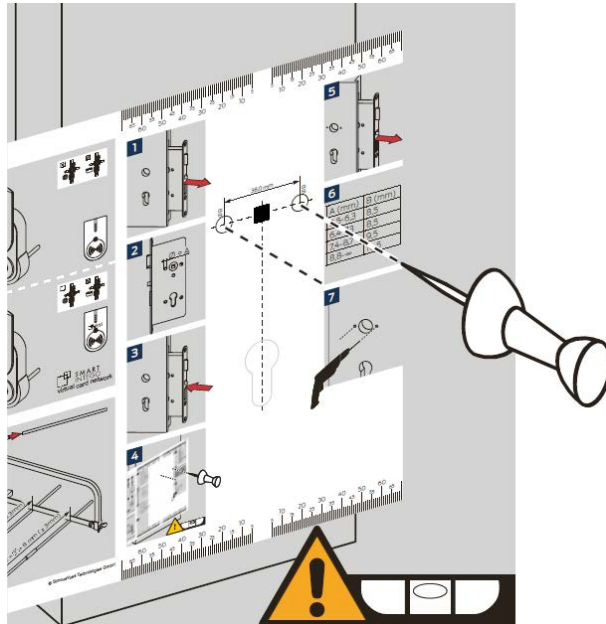

7. Remove the drilling template.
8. Remove the square.
9. Remove the mortise lock.

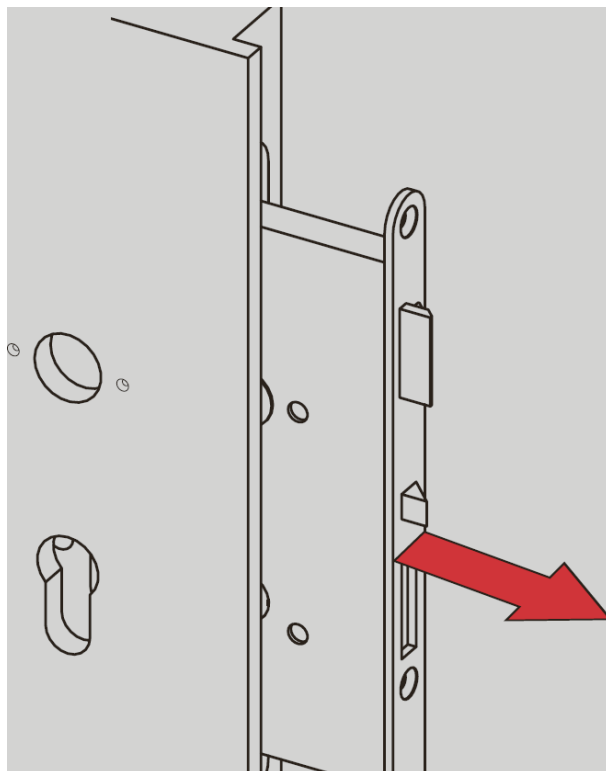

10. Select a suitable drill, depending on the diameter of the mounting holes of your mortise lock (see table).

11. Drill the holes in the door.

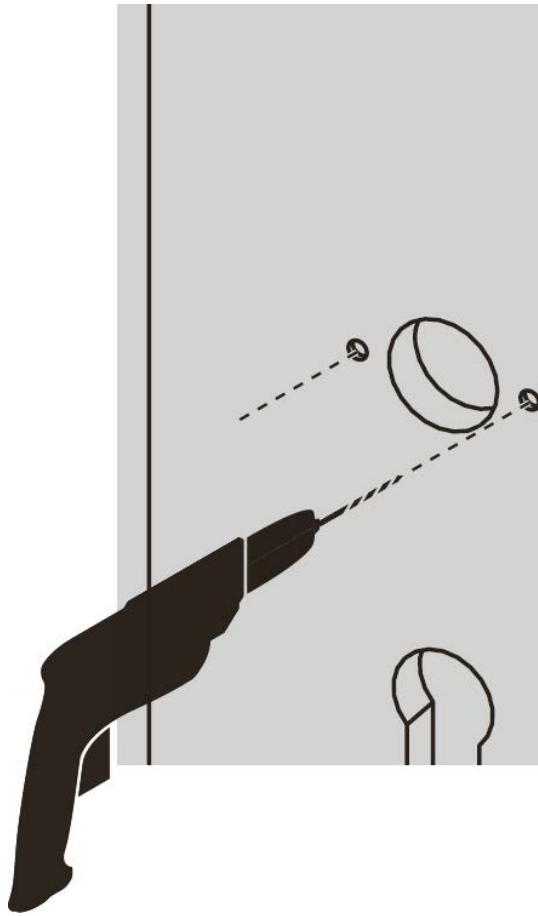

12. Reassemble the mortise lock.

↳ The drill holes are prepared.

Performing programming



NOTE

Duration of initial programming

A large amount of data is transferred during initial programming. The data transfer speed is significantly higher with a SmartStick AX or a SmartCD.MP (and the programming time is therefore shorter).

- If possible, use a SmartStick AX or a SmartCD.MP for initial programming.

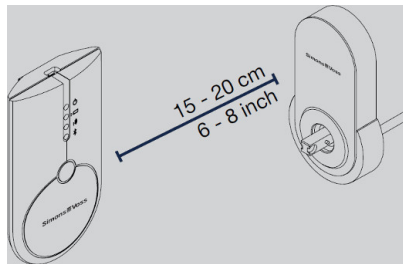

Fig. 1: Programming active (SmartCD.G2)

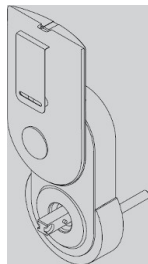

Fig. 2: Programming passive (SmartCD.MP)

- ✓ Locking device added in LSM software.
- ✓ LSM software launched.
- ✓ Programming device connected.

1. Position the programming device.
 2. Programme the SmartHandle AX (see , quick guide or LSM manual for details).
- ↳ SmartHandle AX is programmed.

Shorten screws

Screw/square	Length
2× L1	T - 8 mm (± 3 mm)
2× L2	T + 8 mm (± 3 mm)
Spindle	T + 37 mm (± 3 mm)

1. Measure the thickness of the door (T).

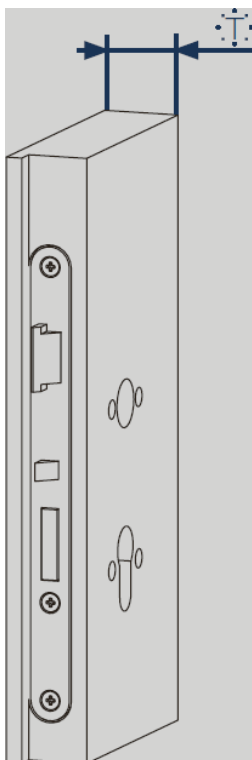

2. Calculate the screw lengths (see table).
3. Select suitable predetermined breaking points that are no more than 3 mm from the calculated length.
4. Separate the predetermined breaking points with pliers.

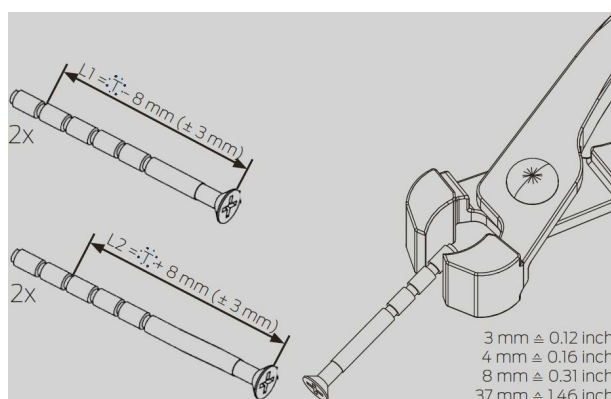

↳ Screws are shortened.

X-variant

If you have ordered version X for very thick doors, your delivery includes an extra long square rod and threaded rods together with extension sleeves. In this case the length specification refers to the total length of the screw (= screw, extension sleeve and threaded rod).

- Proceed as described below.

1. Assemble the screws, the extension sleeves and the threaded rods.

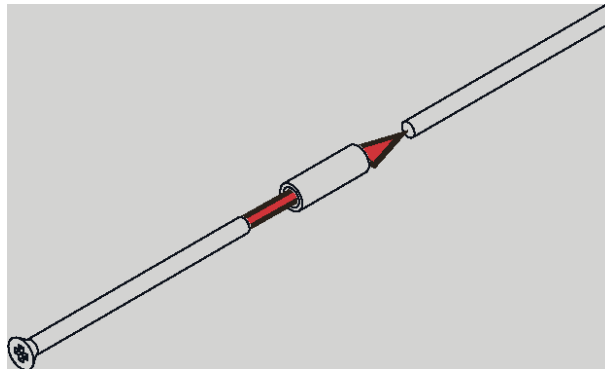

2. Shorten the screws and the square.

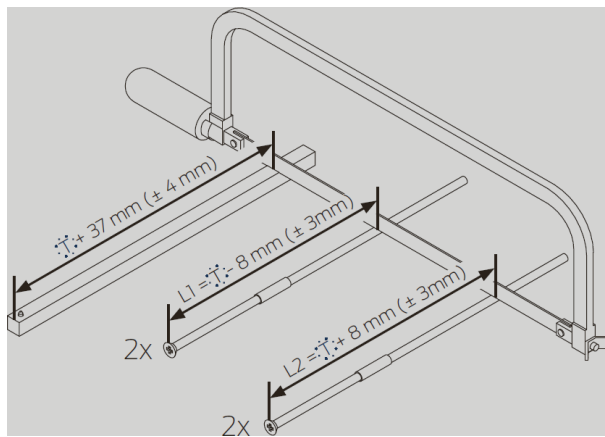

↳ Screws and square of the X-variant are shortened.

Identify door direction

The preparation of the inside handle varies depending on the opening side of the door (DIN R or DIN L).

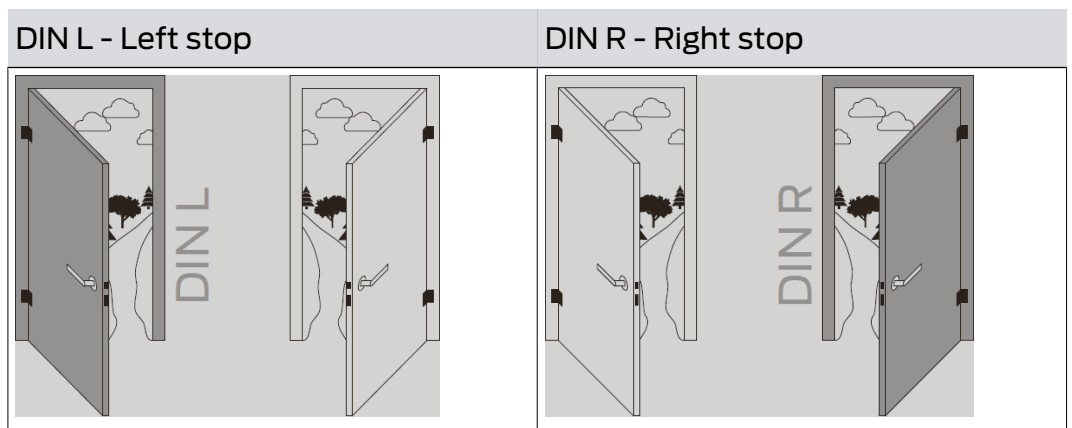

- Compare the illustration with your door and prepare the inside lever handle accordingly (DIN R or DIN L).

Prepare the interior handle (*DIN L)

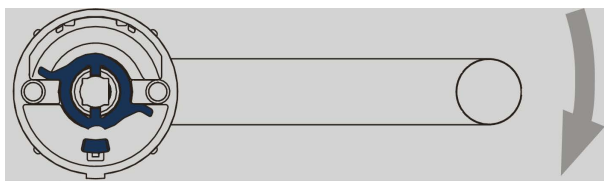

1. Insert the switching plate as shown.

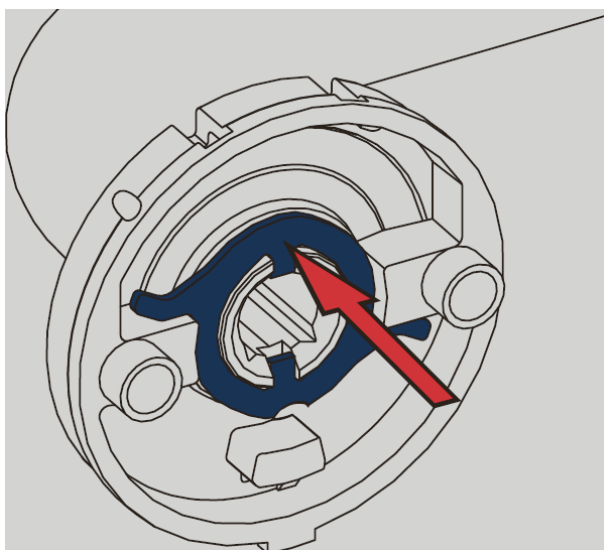

2. Position the spring sub-assembly at an angle to the escutcheon base until it touches the switching plate.

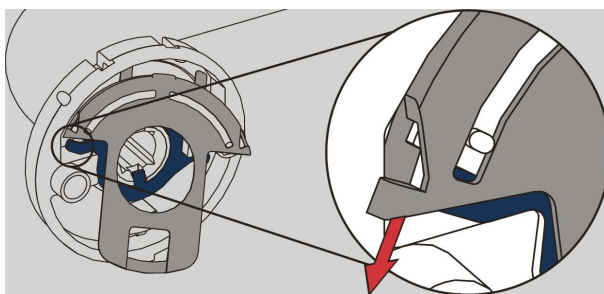

3. Draw the spring sub-assembly back, so that the spring is compressed.

4. Slide the spring sub-assembly pawls into the escutcheon base.

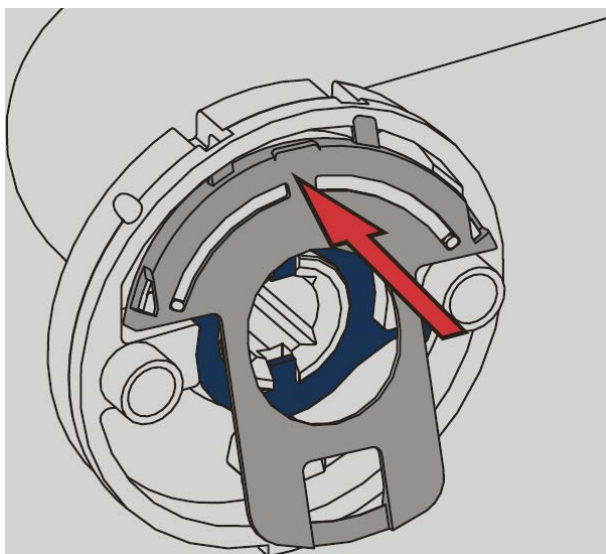

5. Press the rear clip into the designated pawl.

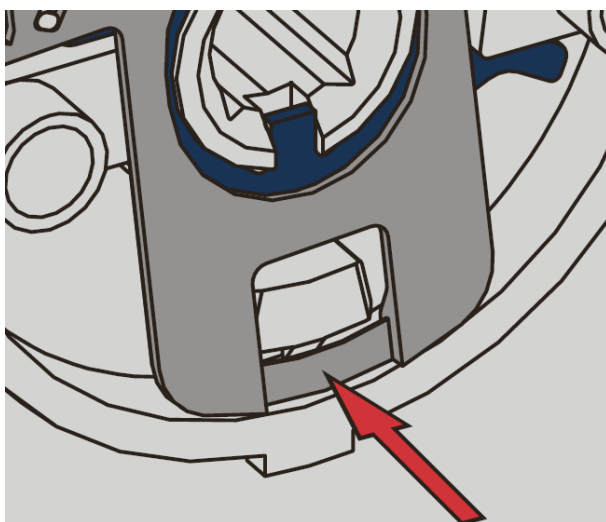

↳ Spring plate is inserted.

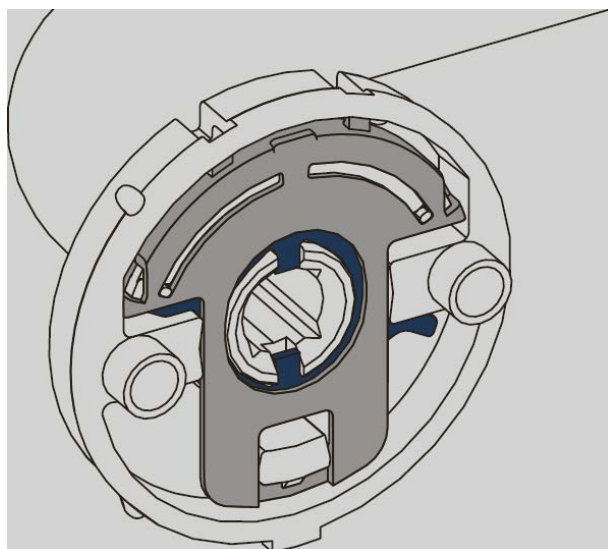

Prepare the interior handle (*DIN R)

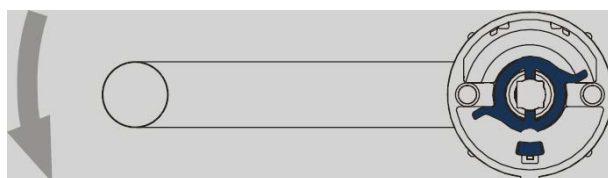

1. Insert the switching plate as shown.

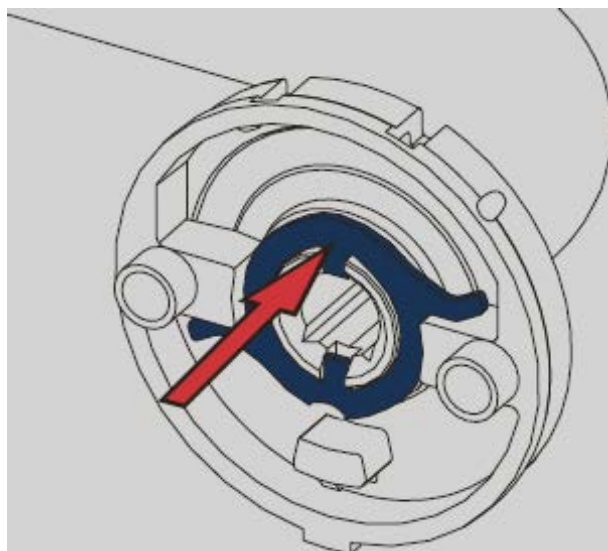

2. Position the spring sub-assembly at an angle to the escutcheon base until it touches the switching plate.

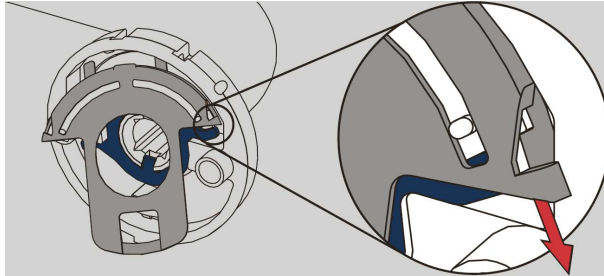

3. Draw the spring sub-assembly back, so that the spring is compressed.
4. Slide the spring sub-assembly pawls into the escutcheon base.

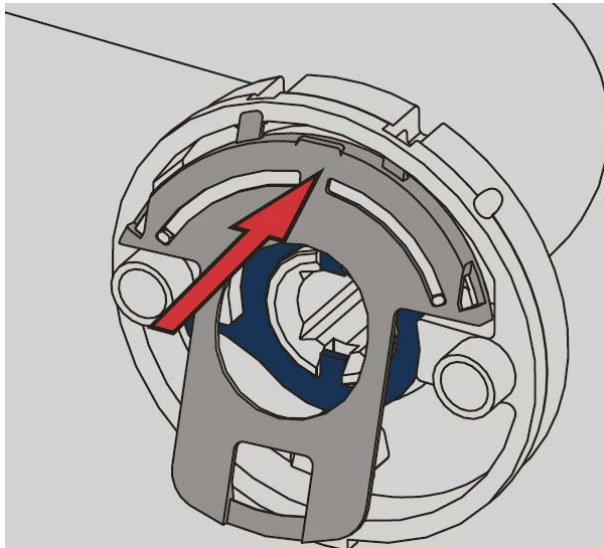

5. Press the rear clip into the designated pawl.

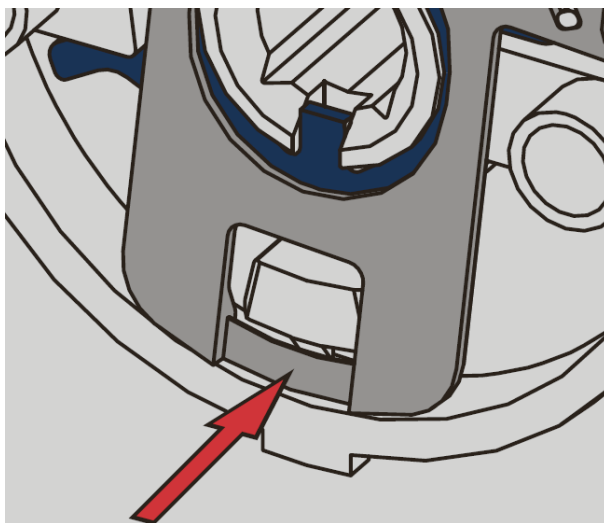

↳ Spring plate is inserted.

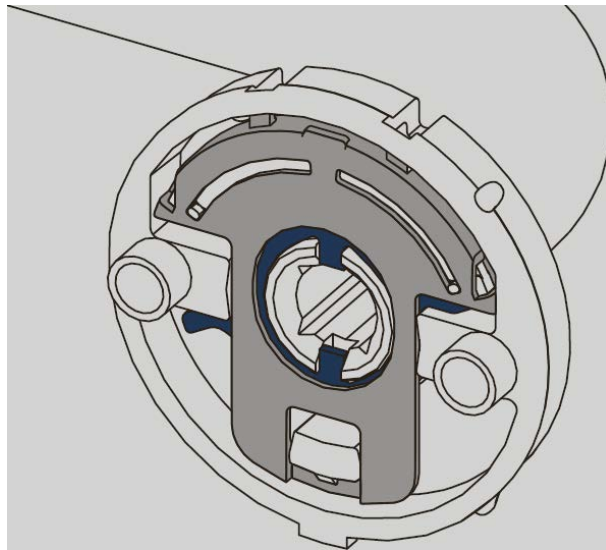

Insert square

7 mm square

The 7 mm square only fits into the 8 mm receptacle of the SmartHandle AX with an adapter shoe (included in the scope of delivery for the 7 mm version).

- Before mounting the 7 mm square, place the adapter shoe on the square.

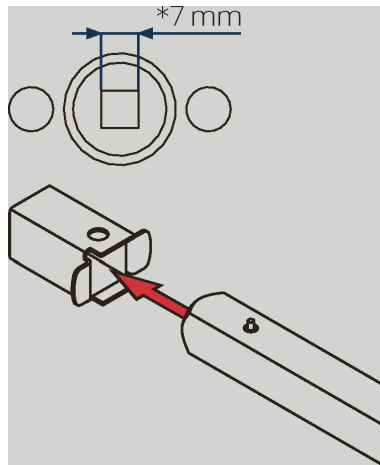

- Slide the square into the outer assembly of the SmartHandle AX until the pin engages the square.

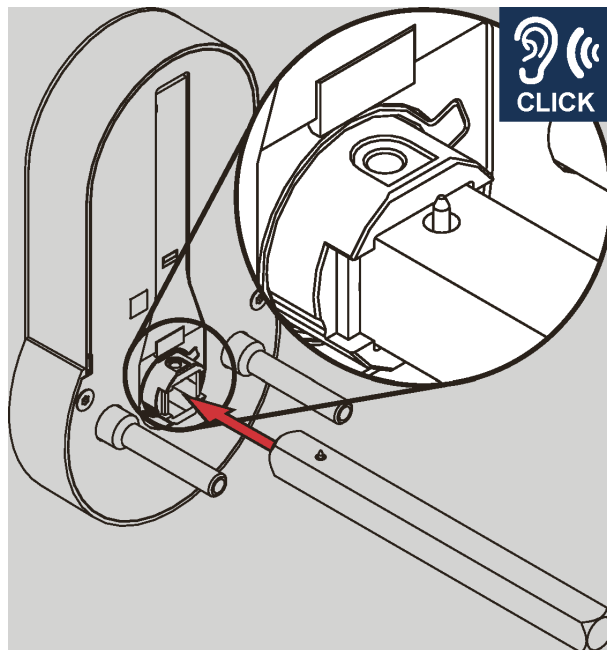

↳ Square is inserted.

Mounting the assembly 1

Square > 8 mm

The SmartHandle AX is supplied with 8 mm square. If the slot of the mortise lock is larger than 8 mm, the square has play.

1. Thicken the square with the push-on sleeve.
2. Use a hammer and centre punch to carefully make a dent in the assembled push-on sleeve.

↳ The slip-on sleeve fits snugly on the square and does not slip easily.

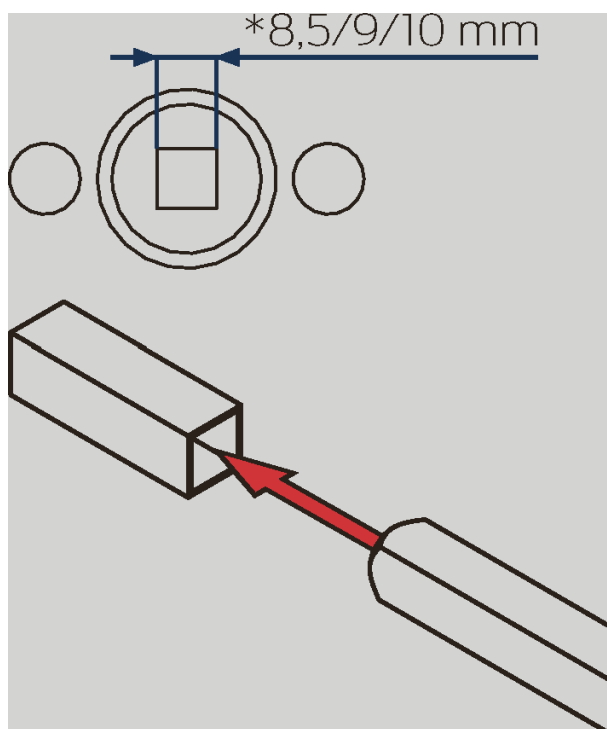

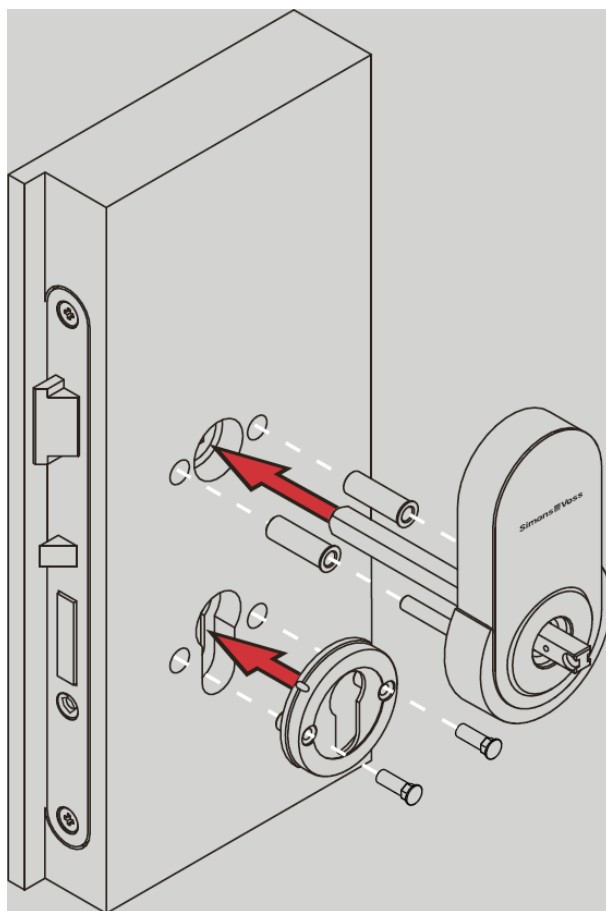

1. Select the appropriate adapter sleeves according to the diameter of the mounting holes of your mortise lock.

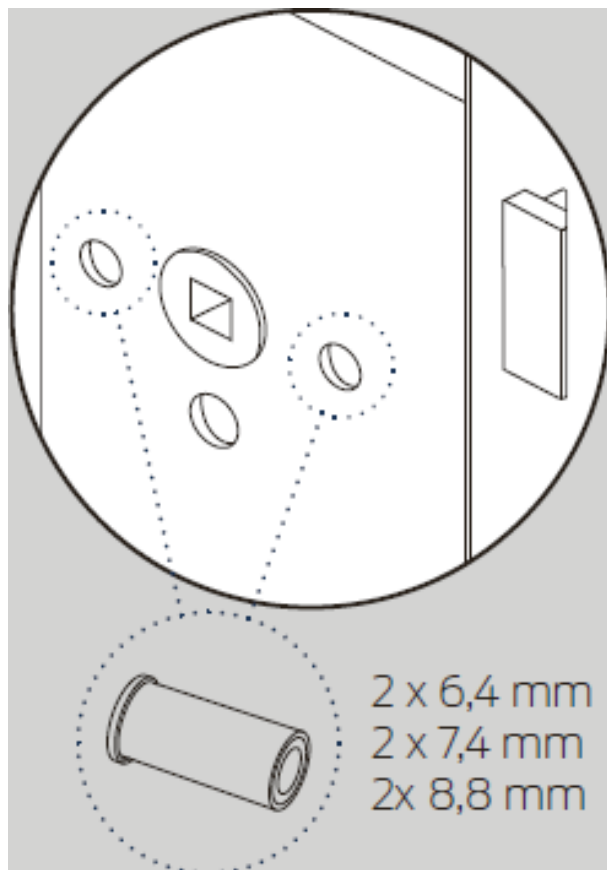

2. Push the adapter sleeves onto your SmartHandle AX.
3. Insert your SmartHandle AX into the door from the outside.
4. Insert the rosette base into the door from the outside.
5. Insert the special sleeve nuts into the rosette base.

Mounting the assembly 2

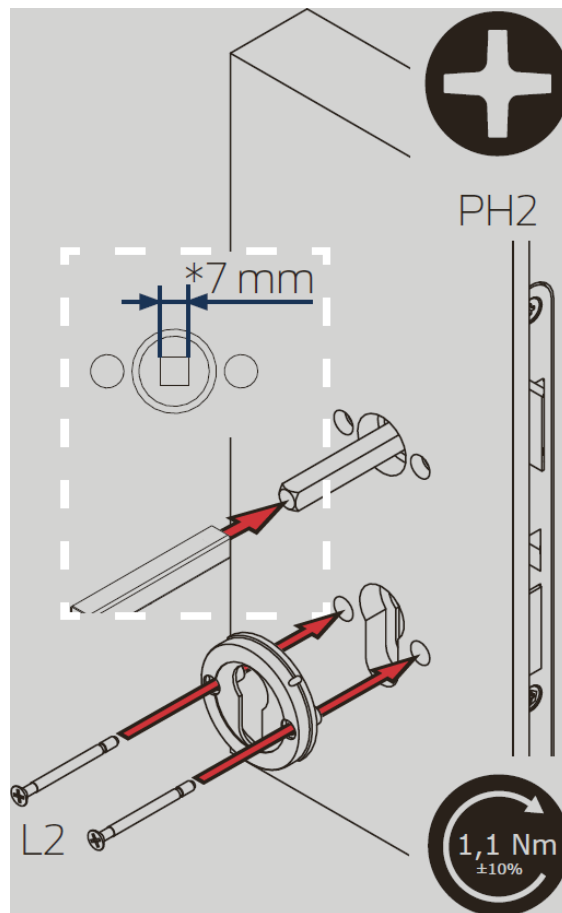
**7 mm square**

The 7 mm square only fits into the 8 mm receptacle of the inside handle of the SmartHandle AX with an adapter sleeve (supplied with the 7 mm version).

❏ Before mounting, insert the adapter sleeve on the free side of the square.

1. Insert the escutcheon base into the door from the inside.
2. Tighten the escutcheon base with the L2 screws (PH2, torque: 1.1 Nm).

Mounting the assembly 3

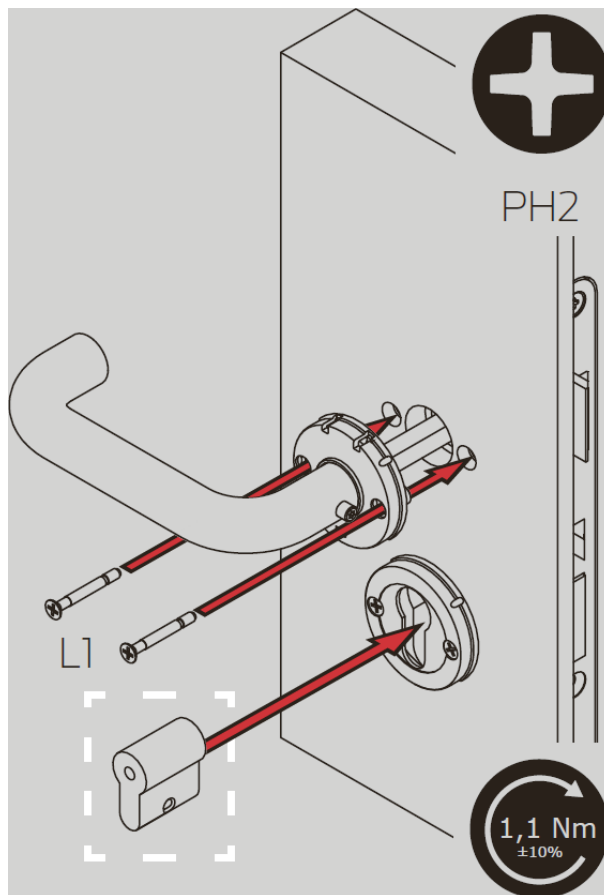

1. If necessary (FH variant), insert the dummy cylinder into the cylinder opening.
2. Place the interior handle on the square.
3. Tighten the base of the interior handle with the L1 screws (PH2, torque: 1.1 Nm).

**NOTE**

Press the handle downwards if there is not enough room.

Mounting the assembly 4

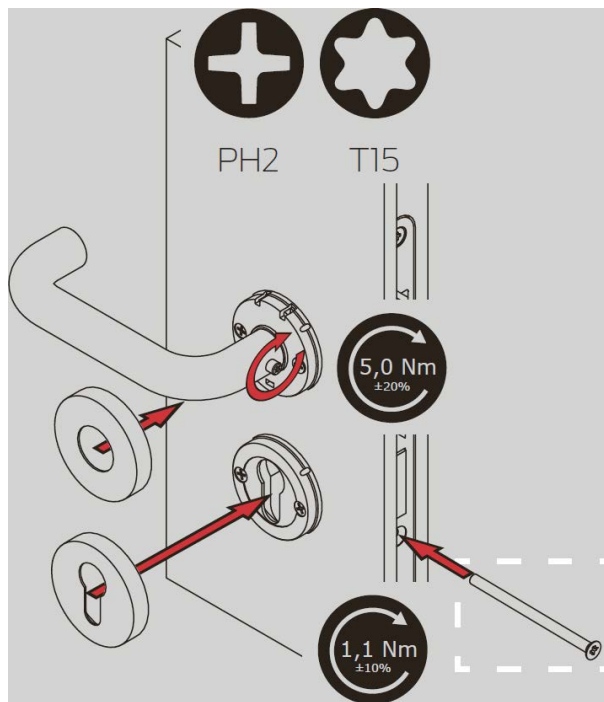

1. Screw the dummy cylinder tight (PH2, torque: 1.1 Nm).
2. Tighten the set screw of the interior handle (T15, torque: 5.0 Nm).
3. Push the cover onto the base of the interior handle until it clicks into place (recess in the cover fits the teeth of the base).
4. Push the escutcheon cover onto the inner rosette base until it clicks into place (recess in the cover fits the teeth of the escutcheon base).

Mounting the assembly 5

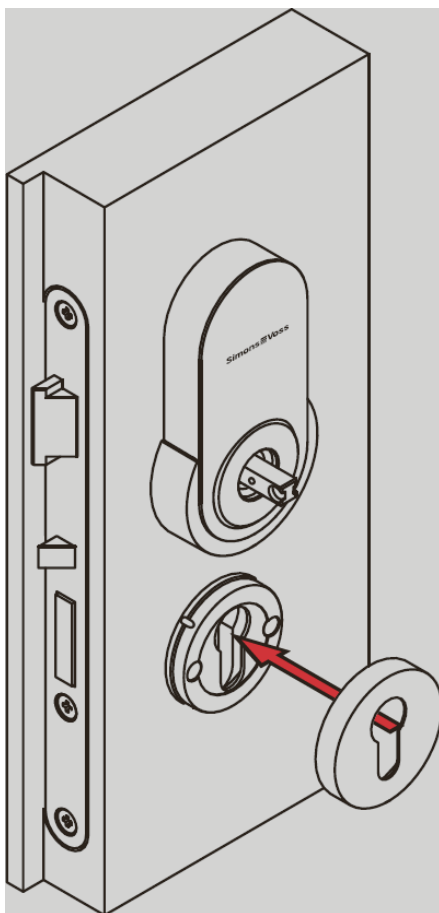

- Slide the escutcheon cover onto the outer escutcheon base until it clicks into place (recess in the cover fits the teeth of the escutcheon base).
- ↳ SmartHandle AX is mounted without an external lever handle.

Mounting the exterior handle

1. Push the exterior handle onto the mount on the SmartHandle AX until it engages.

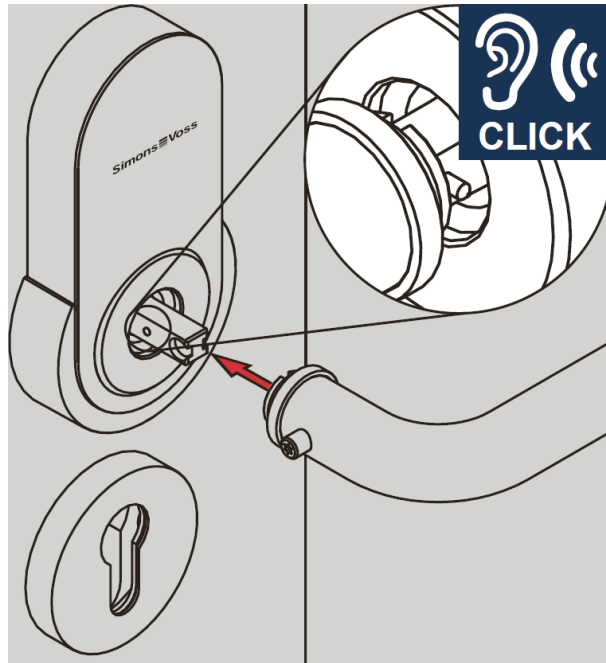

2. Tighten the set screw of the exterior handle (T15, torque: 5.0 Nm).

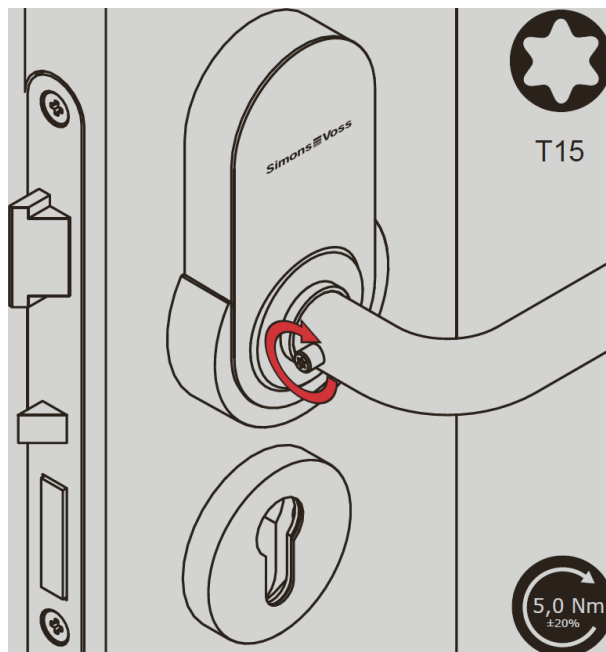

3. SmartHandle AX variable is fully assembled.

7.3 Variants A1 and A2 (suspended mounting)

7.3.1 Contents of packaging

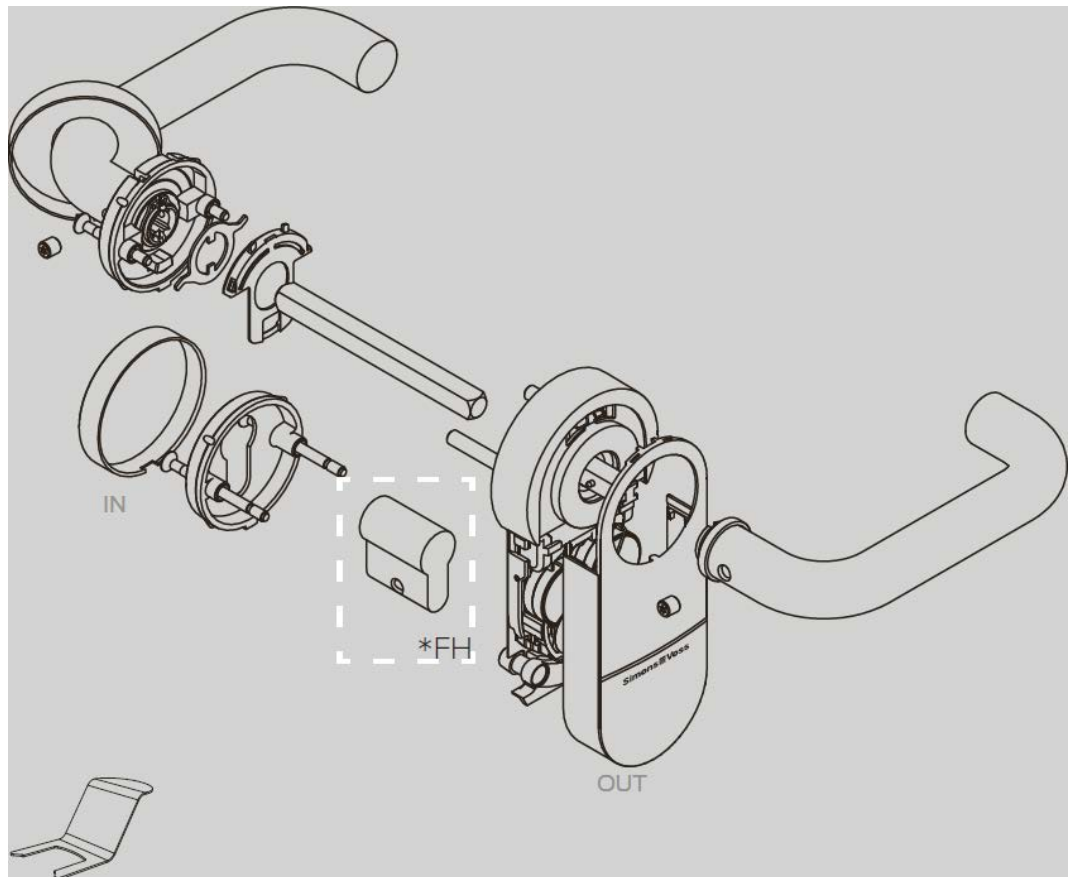

Quantity	Object	
1×	External fitting assembly, incl:	
	4×	Battery (CR2450)
	1×	Inlay
1×	Exterior handle, incl:	
	1×	Headless screw
1×	Interior handle, incl:	
	1×	Headless screw
	1×	pre-assembled escutcheon base
1×	Exchangeable plate	
1×	Spring element	
1×	Escutcheon base for cylinder opening	
1×	Escutcheon cover for interior handle	
1×	Escutcheon cover for cylinder opening	

Quantity	Object
4×	Screw with predetermined breaking points
1×	Spindle
1×	Installation tool
1×	Dummy cylinder (FH version only)
1×	Quick guide with integrated drilling template

7.3.2 Tools

You require the following tools for installation:

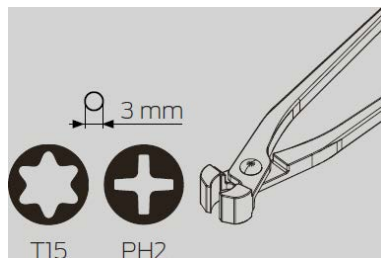

- TX-15 screwdriver
- PH2 screwdriver
- Suitable pliers for shortening screws, e.g. mechanic's nippers
- (X-variant: Saw for shortening square, e.g. hacksaw)

7.3.3 Procedure

Preparing drill holes

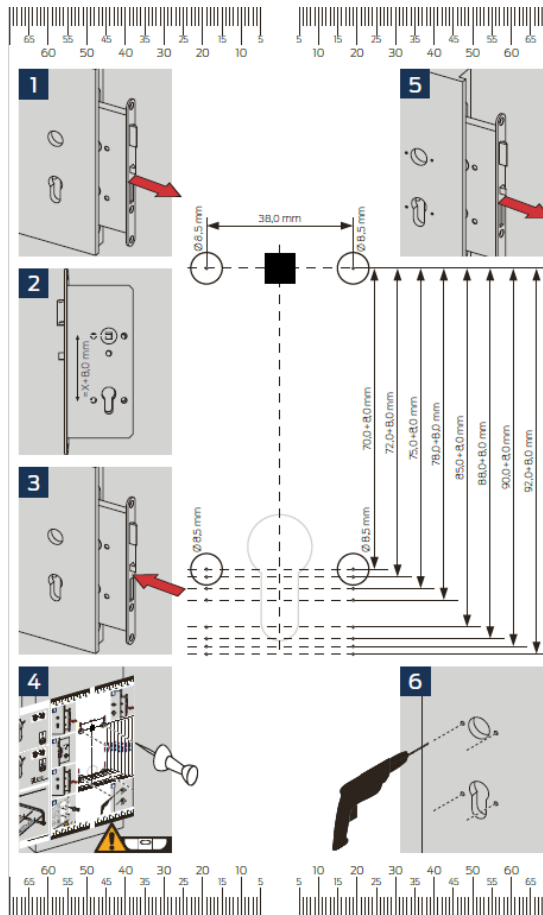

1. Pull out the mortise lock.



2. Measure the distance between the fixing holes of your mortise lock (distance).

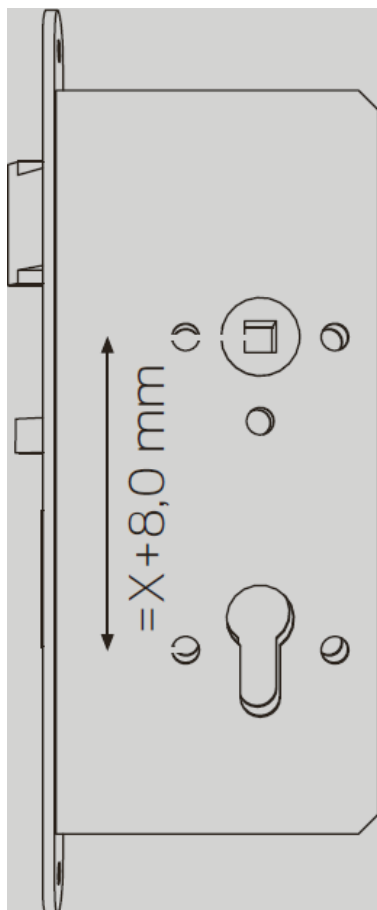

3. Slide the mortise lock back into the door.



4. Insert the square into the mortise lock.
5. Using the square and the recess in the drilling template, position the drilling template on the door.

IMPORTANT

Horizontal alignment required

The drill holes must be aligned horizontally.

- Use the printed scale to ensure that the drilling template is aligned horizontally (equal distances).

6. Select the correct drill holes for the distance of your mortise lock (X+8 mm).
7. Use a pointed object (e.g. pin needle) to pierce the position of the drill holes in the door.

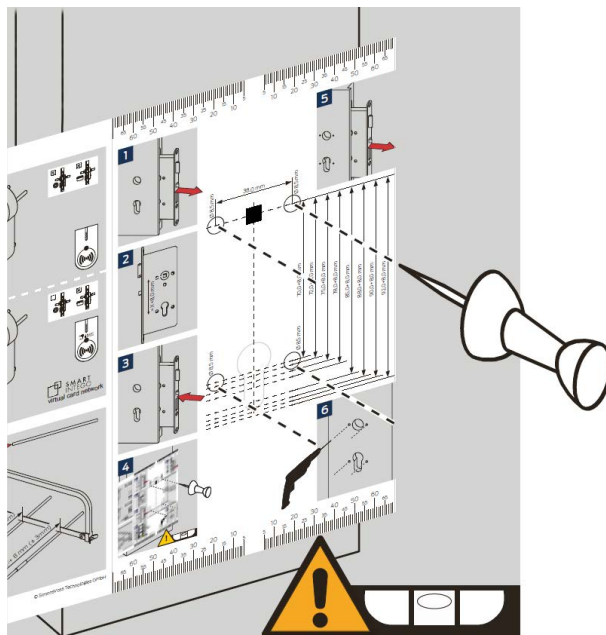

8. Remove the drilling template.
9. Remove the square.

10. Remove the mortise lock.

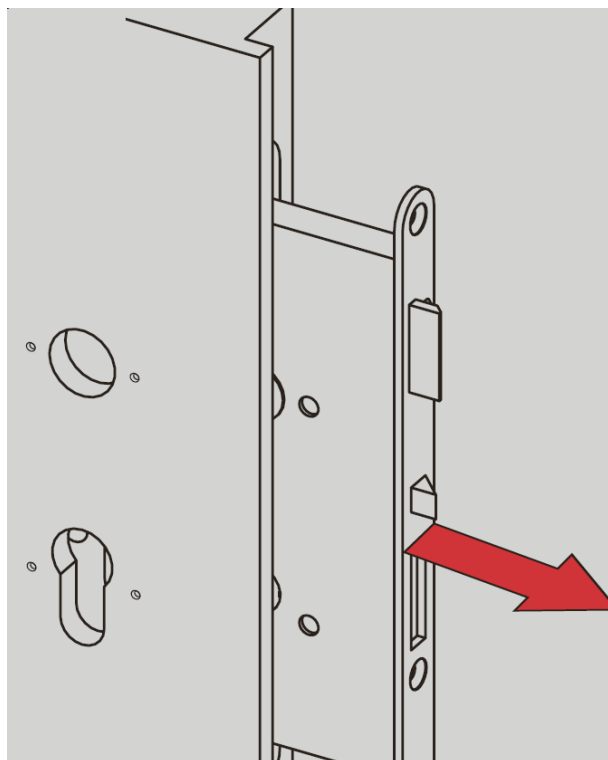

11. Drill the holes in the door (\varnothing 8.5 mm).

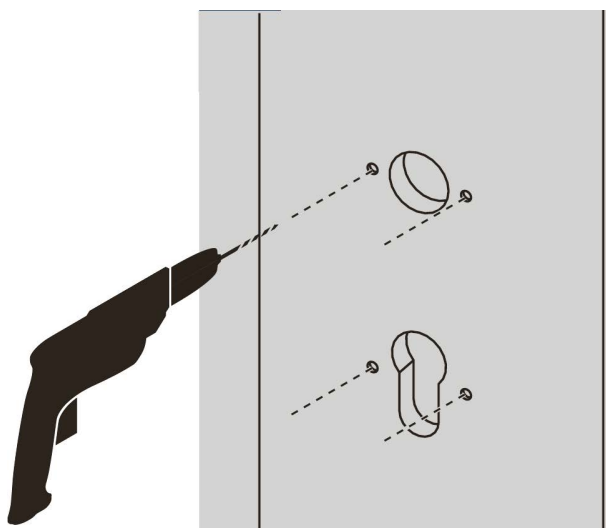

12. Reassemble the mortise lock.

↳ The drill holes are prepared.

Programme

**NOTE****Duration of initial programming**

A large amount of data is transferred during initial programming. The data transfer speed is significantly higher with a SmartStick AX or a SmartCD.MP (and the programming time is therefore shorter).

- If possible, use a SmartStick AX or a SmartCD.MP for initial programming.

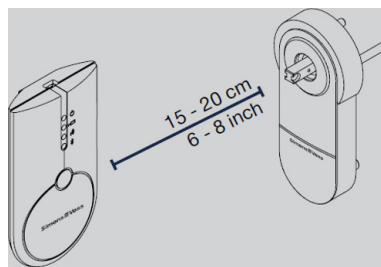

Fig. 3: Programming active (SmartCD.G2)

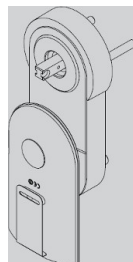

Fig. 4: Programming passive (SmartCD.MP)

- ✓ Locking device added in LSM software.
- ✓ LSM software launched.
- ✓ Programming device connected.

1. Position the programming device.
2. Programme the SmartHandle AX (see , quick guide or LSM manual for details).

↳ SmartHandle AX is programmed.

Shorten screws

Screw/square	Length
2× L1	T - 8 mm (± 3 mm)
2× L2	T + 8 mm (± 3 mm)
Spindle	T + 37 mm (± 4 mm)

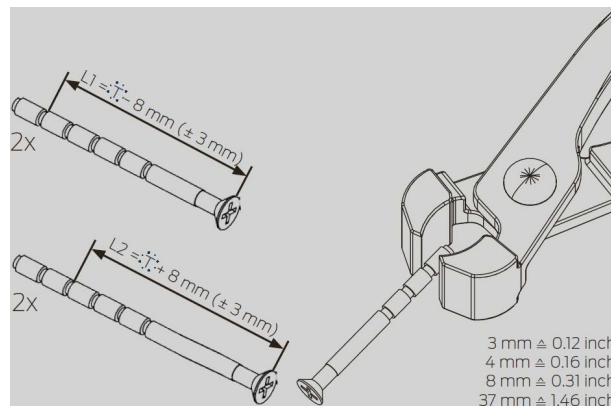

1. Measure the thickness of the door (T).
 2. Calculate the screw lengths.
 3. Select suitable predetermined breaking points which are no more than 3 mm longer than the calculated length.
 4. Separate the predetermined breaking points with the pliers.
- ↳ Screws are trimmed.

X-variant

If you have ordered version X for very thick doors, your delivery includes an extra long square rod and threaded rods together with extension sleeves. In this case the length specification refers to the total length of the screw (= screw, extension sleeve and threaded rod).

▣ Proceed as described below.

1. Assemble the screws, the extension sleeves and the threaded rods.

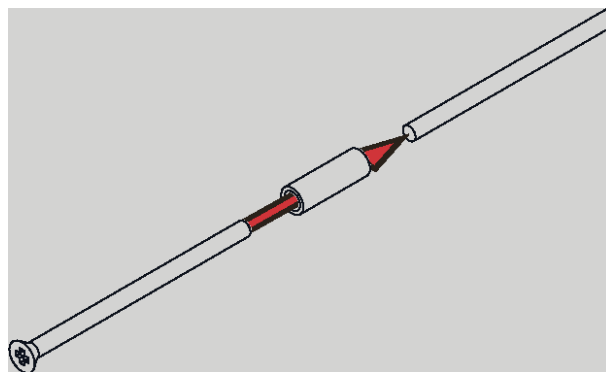

2. Shorten the screws and the square.

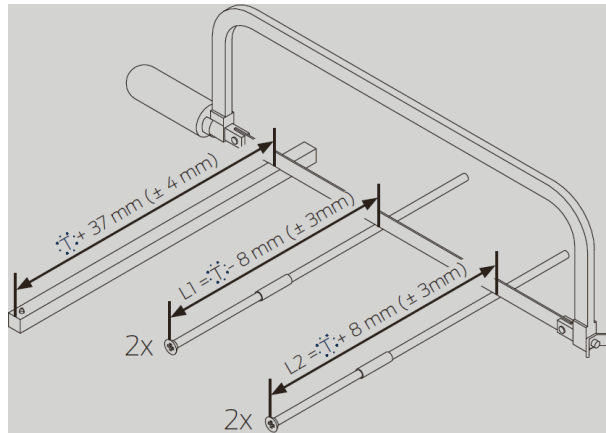

↳ Screws and square of the X-variant are shortened.

Identify door direction

The preparation of the inside handle varies depending on the opening side of the door (DIN R or DIN L).

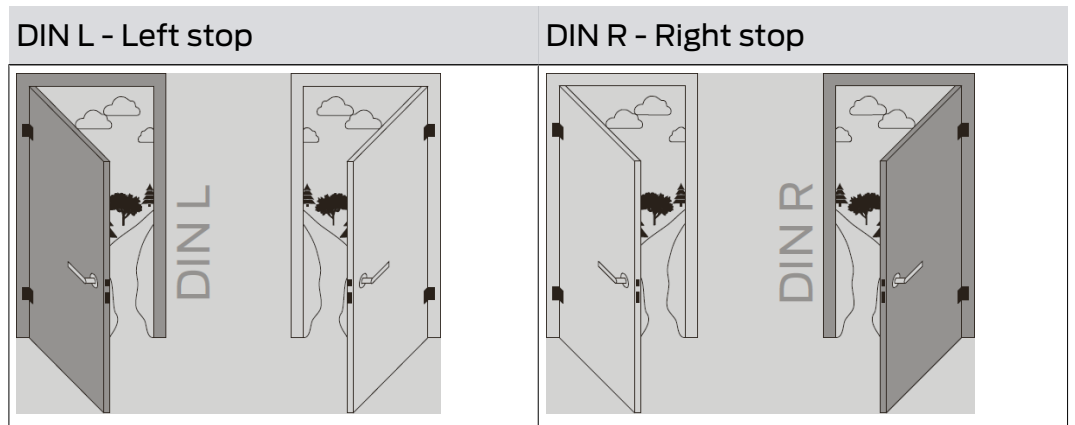

Prepare the interior handle (DIN R)

The mounting is different depending on the opening side of the door (DIN R or DIN L).



1. Insert the switching plate as shown.

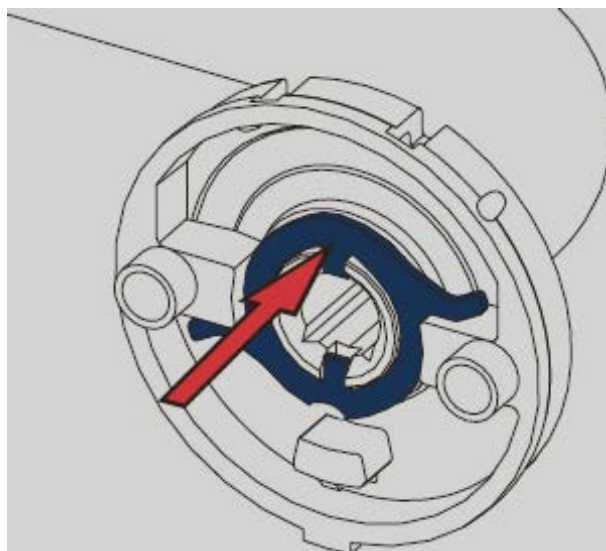

2. Position the spring sub-assembly at an angle to the escutcheon base until it touches the switching plate.

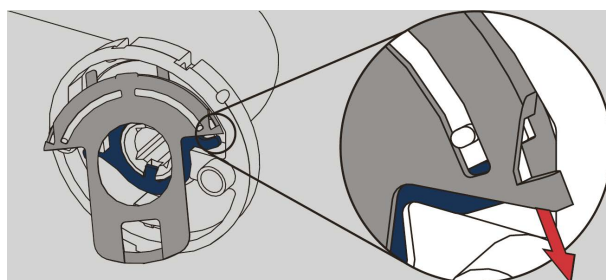

3. Draw the spring sub-assembly back, so that the spring is compressed.
4. Slide the spring sub-assembly pawls into the escutcheon base.

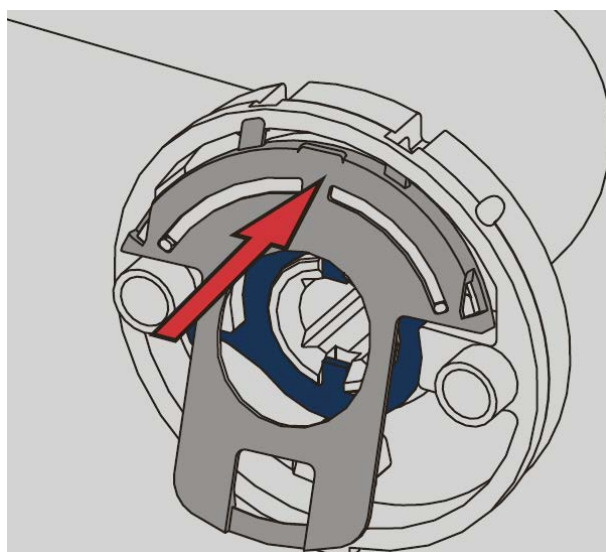

5. Press the rear clip into the designated pawl.

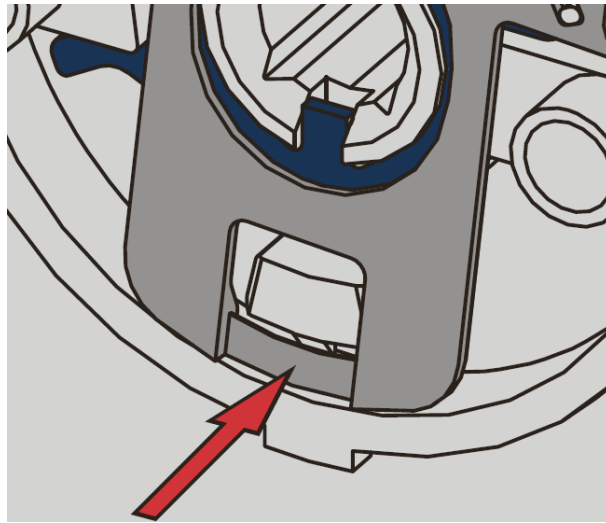

↳ Spring plate is inserted.

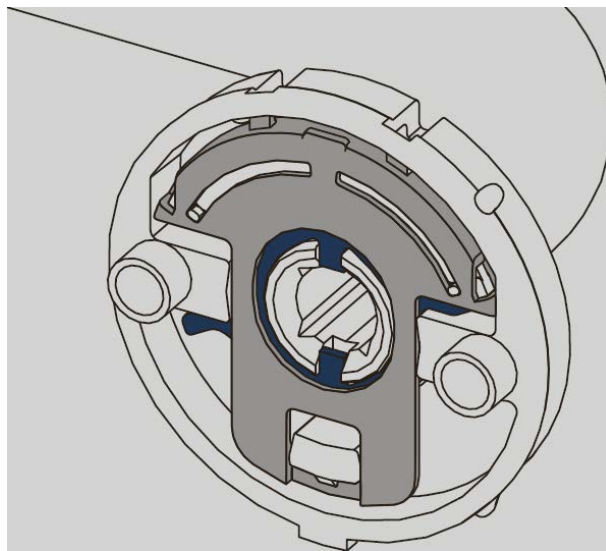

Prepare the interior handle (DIN L)

The mounting is different depending on the opening side of the door (DIN R or DIN L).

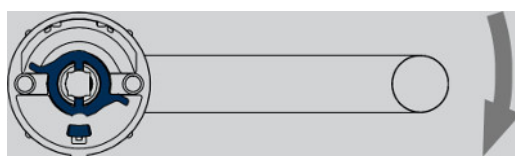

1. Insert the switching plate as shown.

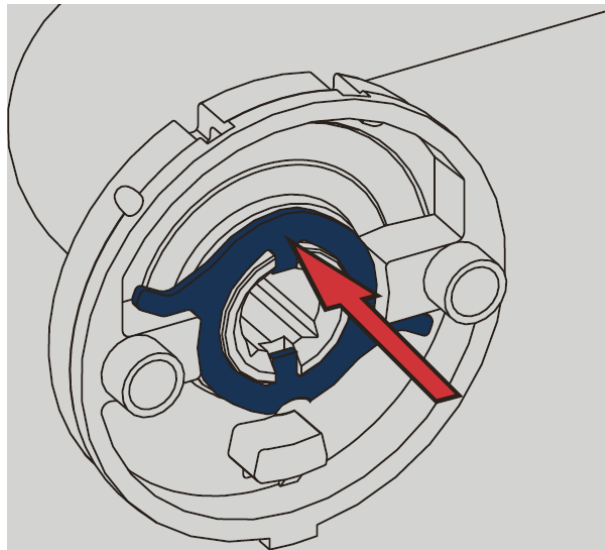

2. Position the spring sub-assembly at an angle to the escutcheon base until it touches the switching plate.

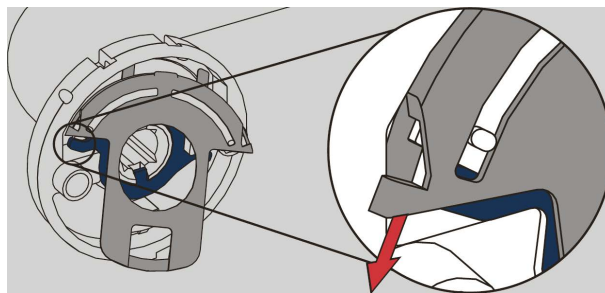

3. Draw the spring sub-assembly back, so that the spring is compressed.
4. Slide the spring sub-assembly pawls into the escutcheon base.

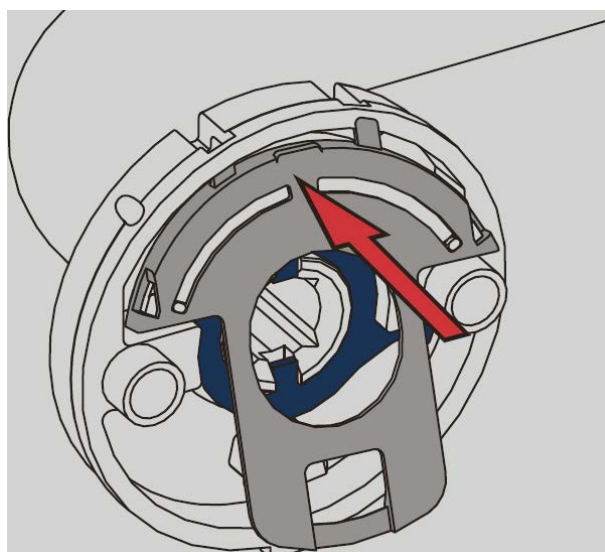

5. Press the rear clip into the designated pawl.

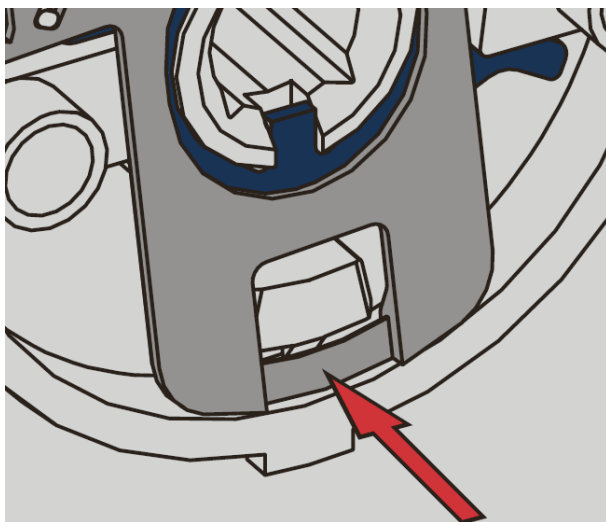

↳ Spring plate is inserted.

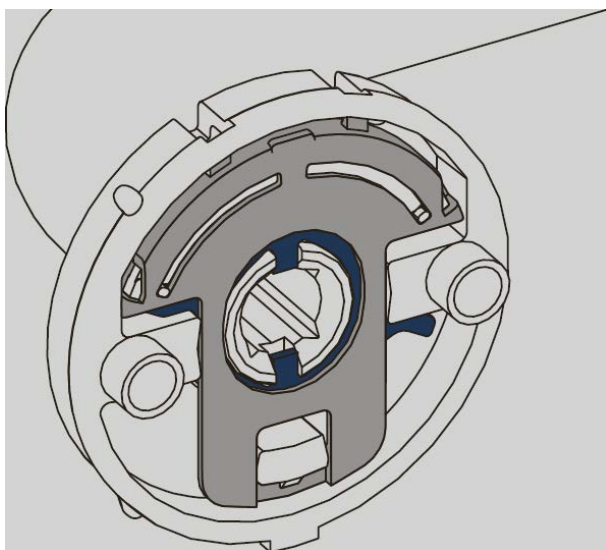

Insert square

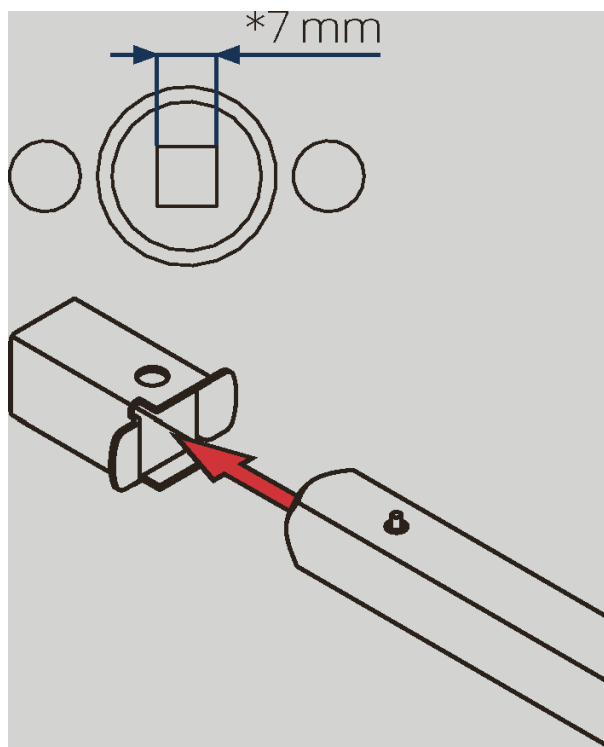
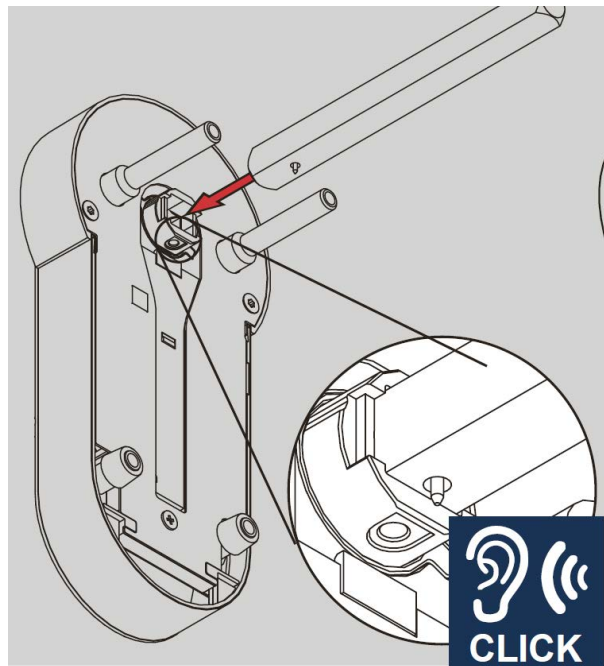

If you use a 7 mm spindle, attach the adapter shoe to the spindle before fitting the spindle.

- Insert the spindle into the outer sub-assembly until the pin locks into the spindle.
- ↳ Spindle is inserted.

Mount the assembly

**NOTE****Square > 8 mm**

The SmartHandle AX is supplied with 8 mm square. If the slot of the mortise lock is larger than 8 mm, the square has play.

1. Thicken the square with the push-on sleeve.
2. Use a hammer and centre punch to carefully make a dent in the assembled push-on sleeve.

↳ The slip-on sleeve fits snugly on the square and does not slip easily.

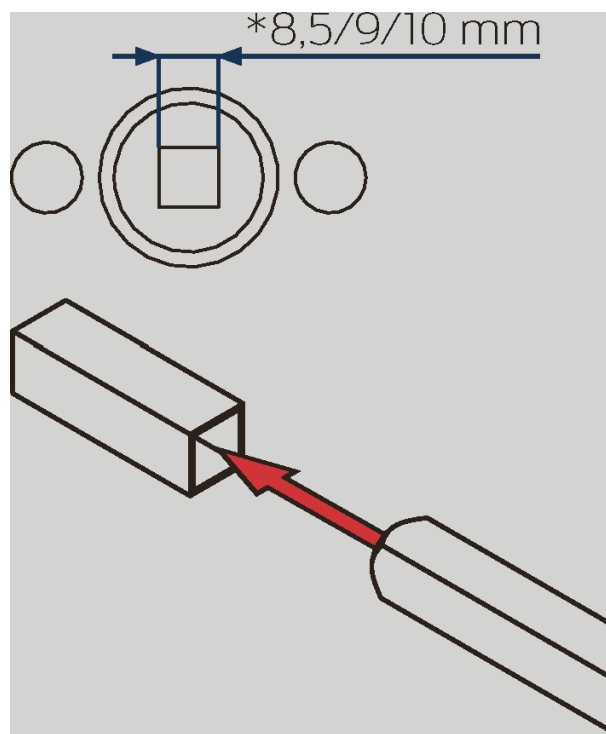

1. Push the sub-assembly with the spindle into the door from the outer side.

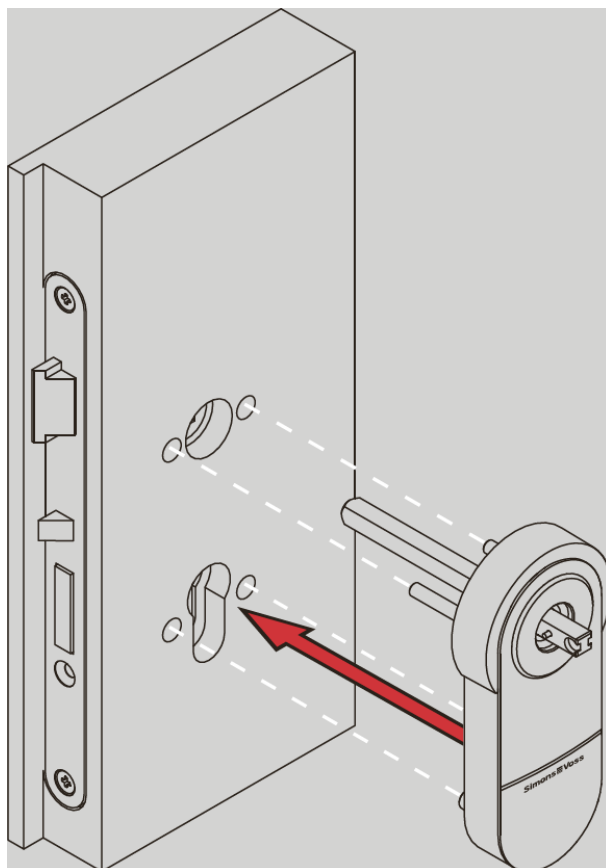

2. Position the escutcheon base for the cylinder opening on the other side of the door.
3. Screw the escutcheon base to the assembly using the L2 screws (PH2, torque: 1.1 Nm).

**NOTE**

If you use a 7 mm spindle, place the adapter sleeve on the free side of the spindle.

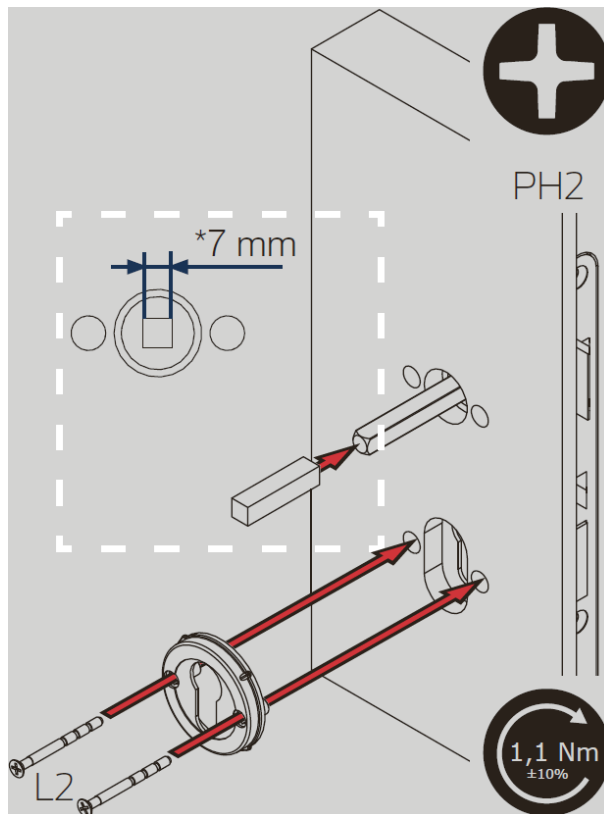

4. Place the inner side handle on the spindle.
5. Screw the handle to the assembly with the L1 screws (PH2, torque: 1.1 Nm).

**NOTE**

Press the handle downwards if there is not enough room.

**NOTE****Mount the dummy cylinder (FH only)**

Slide the dummy cylinder through the mounted escutcheon base into the mortise lock and tighten the dummy cylinder with a suitable screw (PH2, torque: 1.1 Nm).

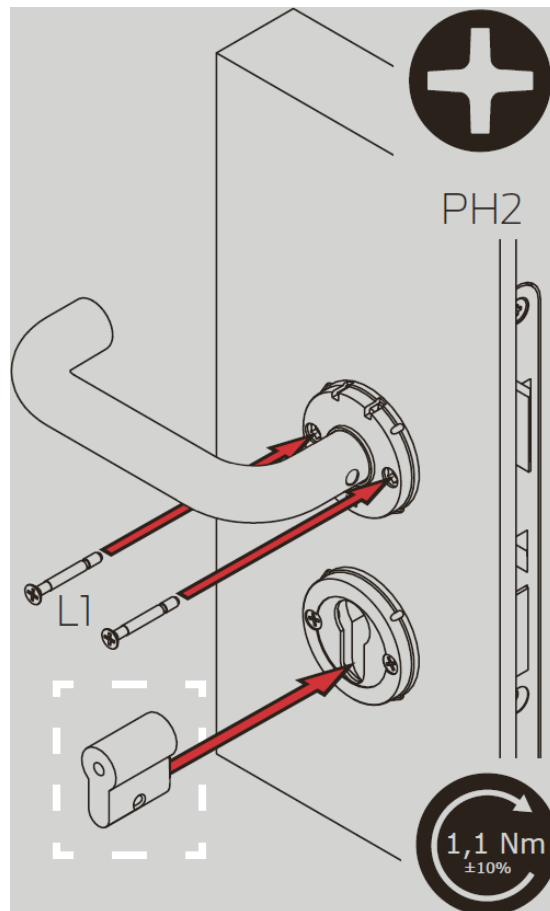

6. Screw the headless screw into the handle to fix it in place (T15, torque: 5.0 Nm)

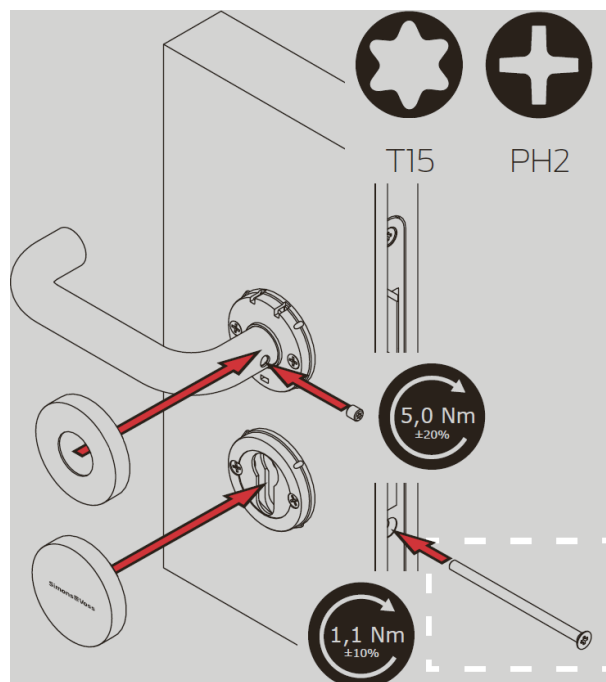

7. Slide the escutcheon along the handle and press the escutcheon onto the escutcheon base until it locks into position.

8. Press the escutcheon onto the escutcheon base on the cylinder opening until it locks into place.

↳ The sub-assembly is mounted.

Fit exterior handle

1. Push the outer handle into the sub-assembly until the pin locks into the spindle.

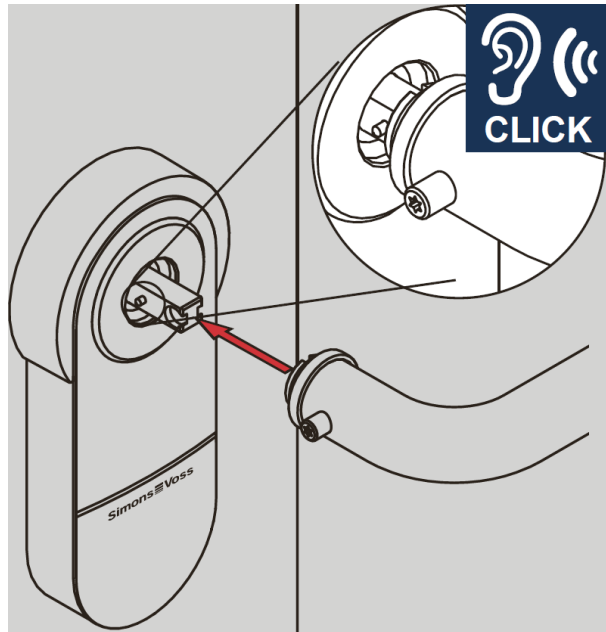

2. Screw the headless screw into the handle to fix it in place (T15, torque: 5.0 Nm)

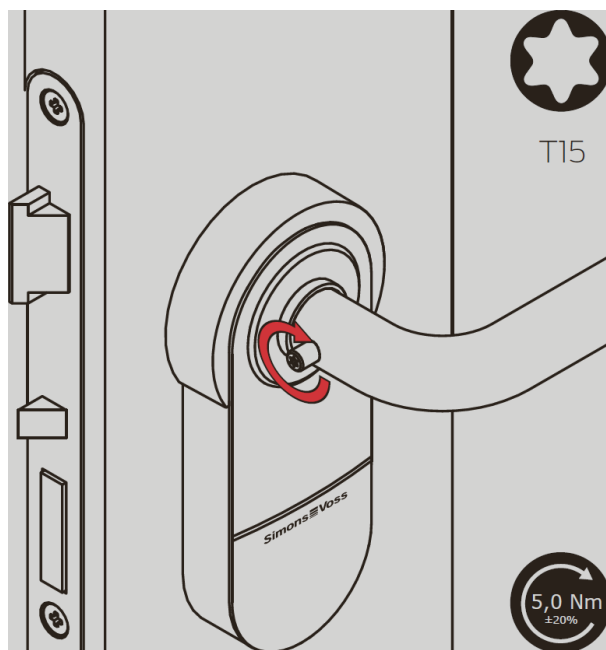

↳ SmartHandle AX mounted.

7.3.4 Glass door fitting

You can also use an A1 SmartHandle AX design with an optional lock case on glass doors.

The glass door must feature the following holes for SimonsVoss glass door fittings (dimensions in mm):

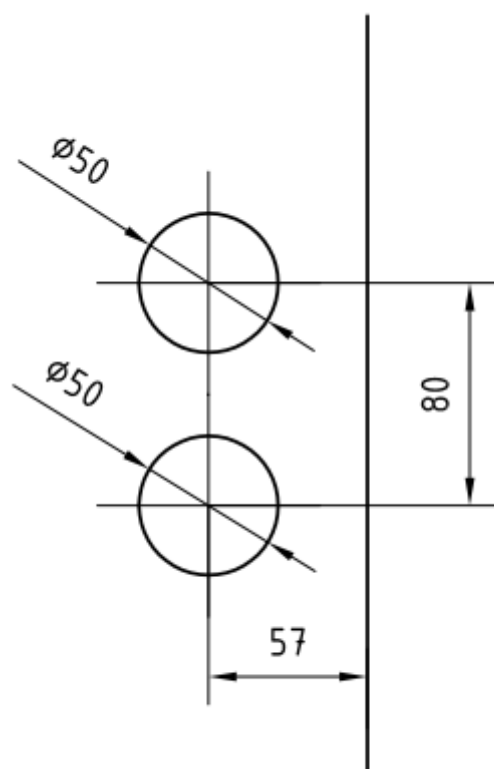

7.4 Variant A3 (steel frame)

7.4.1 Contents of packaging

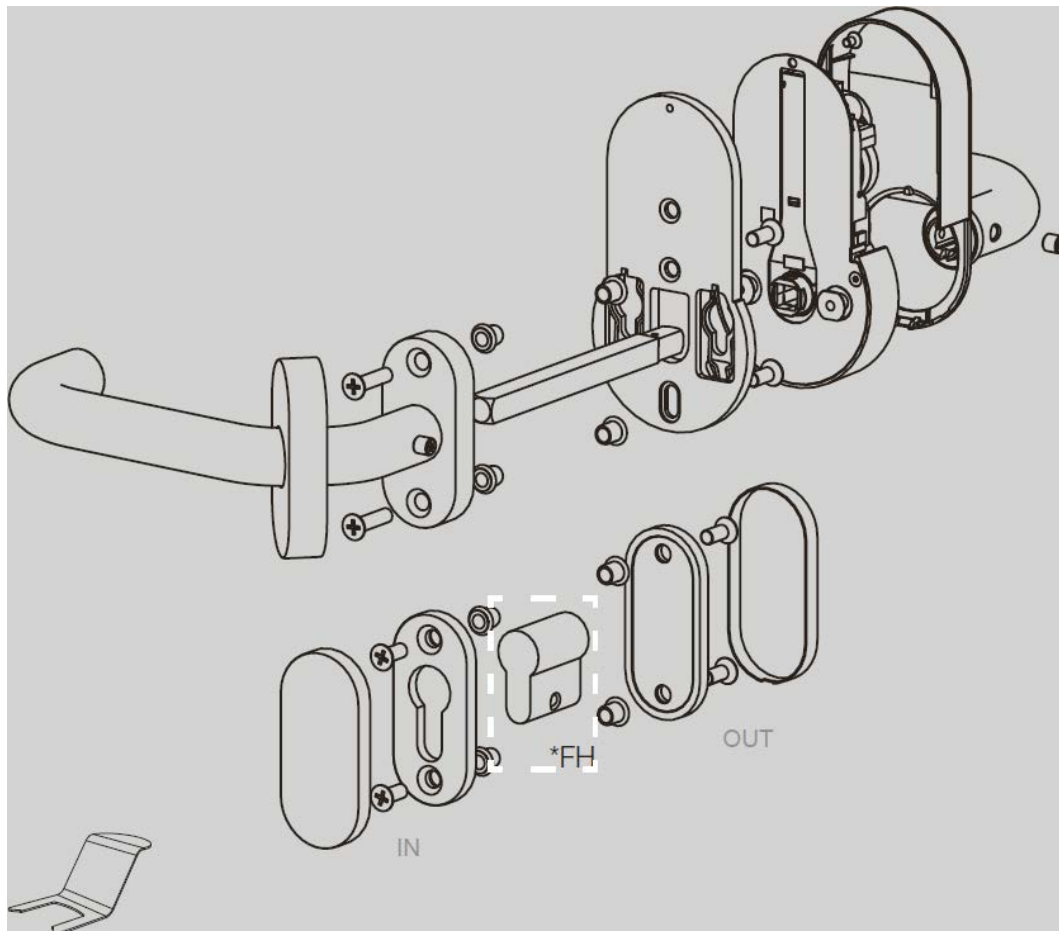

Quantity	Object	
1x	External fitting assembly, incl:	
	4x	Battery (CR2450)
	1x	Inlay
1x	Exterior handle, incl:	
	1x	Headless screw
1x	Interior handle, incl:	
	1x	Headless screw
	1x	pre-assembled escutcheon base
1x	adapter plate	
2x	Screws for adapter plate	
4 x	Screws for escutcheon base (cylinder)	
2x	Screws for inside handle escutcheon base	

Quantity	Object
1×	Escutcheon base for cylinder opening (plastic with metal insert)
1×	Escutcheon covers for inside handle
2×	Escutcheon covers for cylinder opening
8×	Blind rivet nut
1×	Square with circlip
1×	Installation tool
1×	Dummy cylinder (FH version only)
1×	Quick guide with integrated drilling template

7.4.2 Tools

You require the following tools for installation:

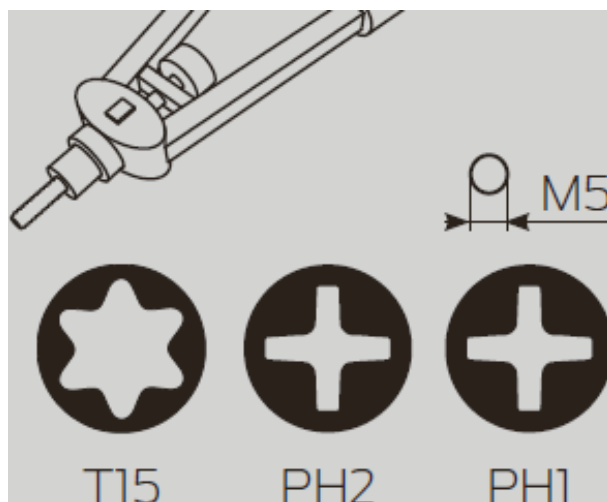

- TX-15 screwdriver
- PH2 screwdriver
- PH1screwdriver
- Rivet nut pliers for M5 thread
- (X-variant: Saw for shortening square, e.g. hacksaw)

7.4.3 Procedure

Preparing drill holes

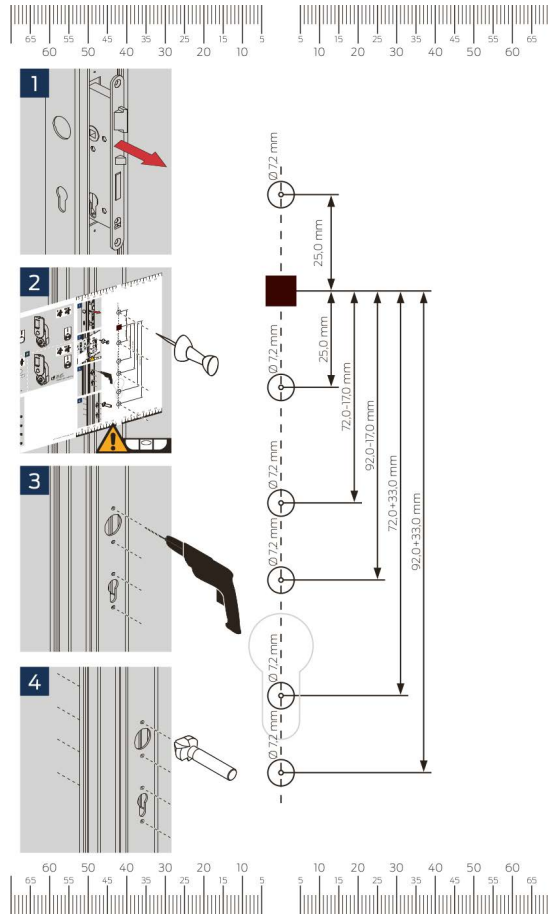

1. Pull out the mortise lock.

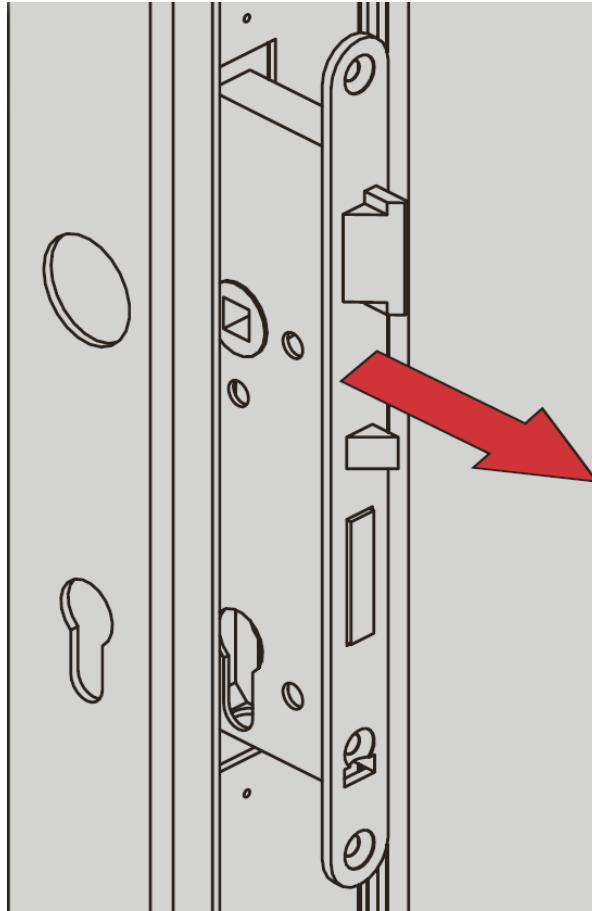

2. Measure the distance between the fixing holes of your mortise lock (distance).
3. Slide the mortise lock back into the door.
4. Insert the square into the mortise lock.
5. Using the square and the recess in the drilling template, position the drilling template on the door.

IMPORTANT

Horizontal alignment required

The drill holes must be aligned horizontally.

- Use the printed scale to ensure that the drilling template is aligned horizontally (equal distances).

6. Select the correct drill holes for the removal of your mortise lock (X-17 mm or X+33 mm).

7. Use a pointed object (e.g. pin needle) to pierce the position of the drill holes in the door.

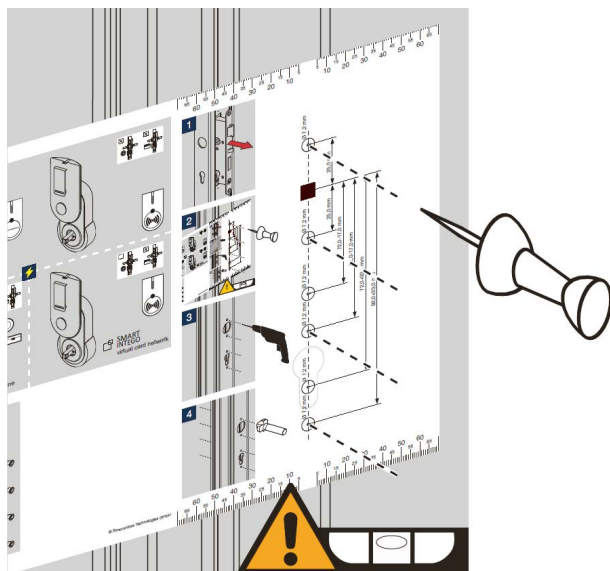

8. Remove the drilling template.
9. Remove the square.
10. Remove the mortise lock.
11. Drill the holes in the door ($\text{Ø } 7.2 \text{ mm}$).

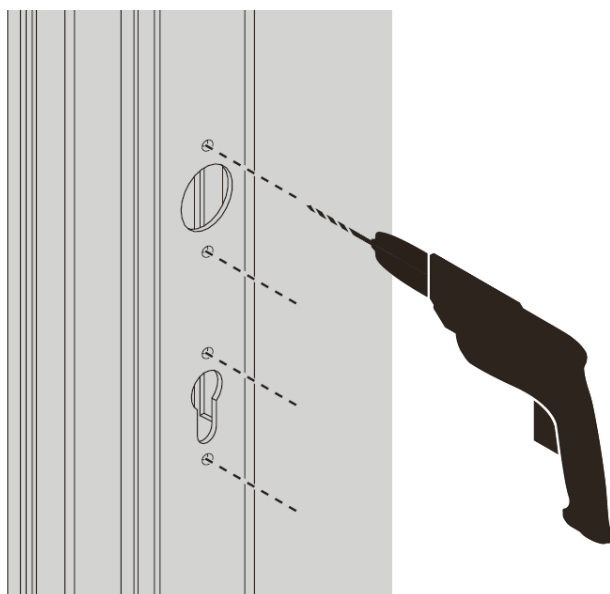

12. Debur the drill holes so that the blind rivet nuts will later lie flat.

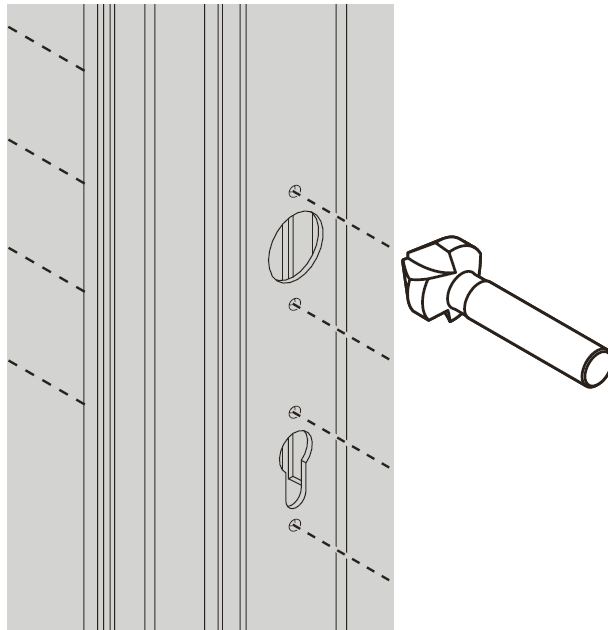

13. Reassemble the mortise lock.

↳ The drill holes are prepared.

Programme



NOTE

Duration of initial programming

A large amount of data is transferred during initial programming. The data transfer speed is significantly higher with a SmartStick AX or a SmartCD.MP (and the programming time is therefore shorter).

- If possible, use a SmartStick AX or a SmartCD.MP for initial programming.

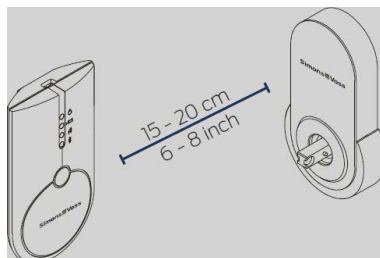

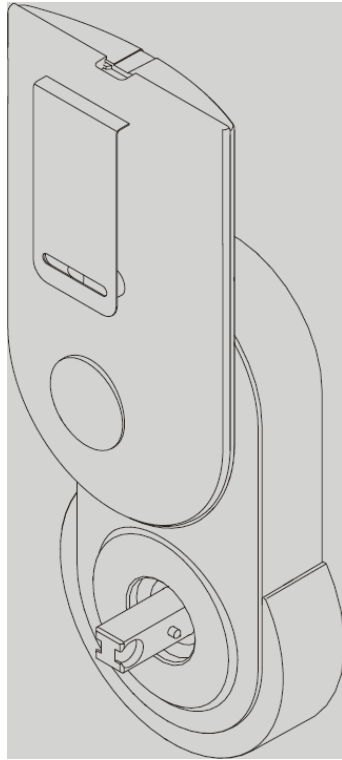

- ✓ Locking device added in LSM software.
 - ✓ LSM software launched.
 - ✓ Programming device connected.
1. Position the programming device.
 2. Programme the SmartHandle AX (see , quick guide or LSM manual for details).
- ↳ SmartHandle AX is programmed.

Prepare the square

Shorten the square of the extra long version (X)

The square of the extra long version is supplied with 200 mm.

- If you have the extra-long version, you shorten the square yourself with a suitable saw (e.g. hacksaw): Length = door thickness + 58 mm, tolerance ± 1 mm).
-

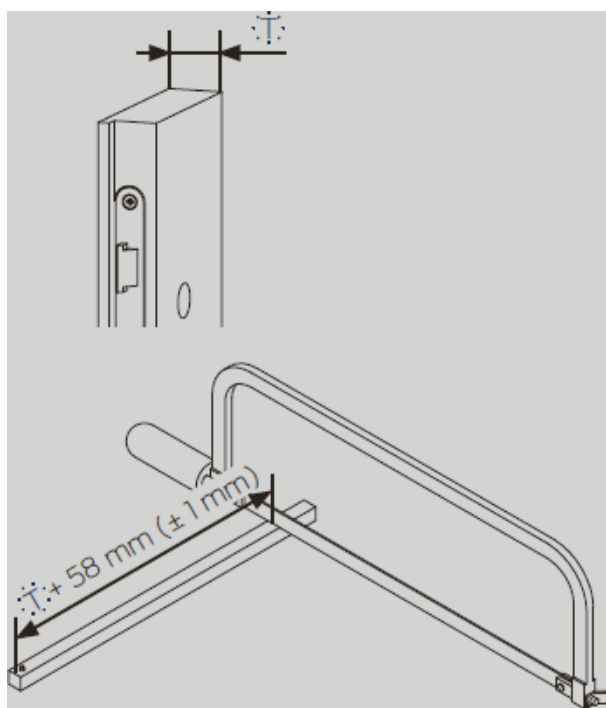

Place blind rivet nuts

- ✓ Holes for blind rivet nuts available.
- Mount the blind rivet nuts with the rivet nut pliers in the holes of the tubular frame.

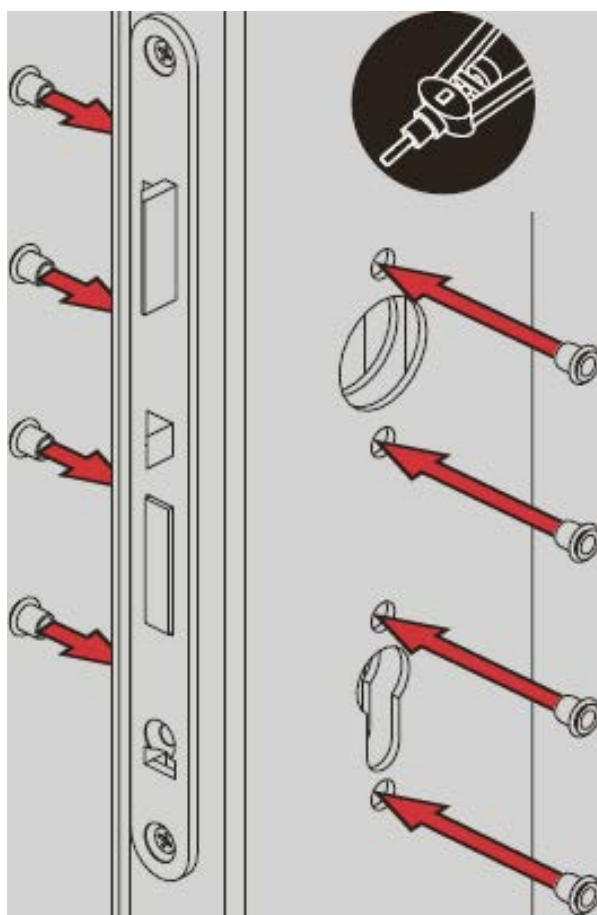

↳ Blind rivet nuts are set.

Mount external fitting

✓ Blind rivet nuts set.

1. Tighten the adapter plate on the outside (PH2, torque: 1.1 Nm).

2. Screw the escutcheon base to the outside (PH2, torque: 1.1 Nm).

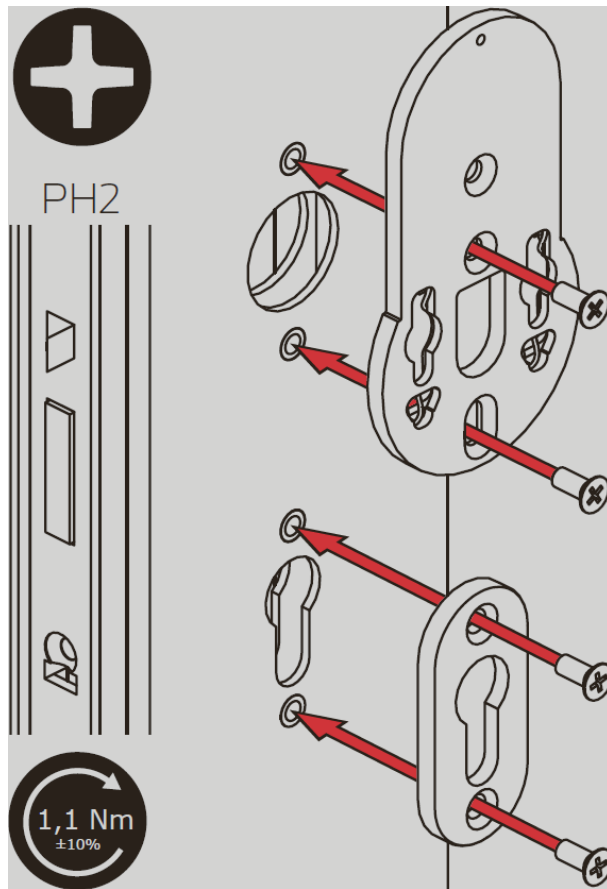

NOTE

Alignment of the adapter plate

The adapter plate contains spring elements and creates a form fit with the fitting.

- Make sure that the spring elements are located on the adapter plate on the door side.

3. Insert the fitting into the adapter plate.

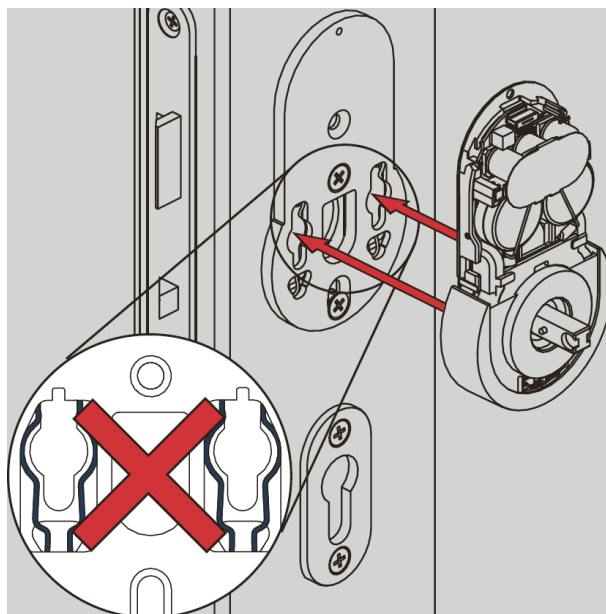

4. Slide the fitting down as far as it will go.

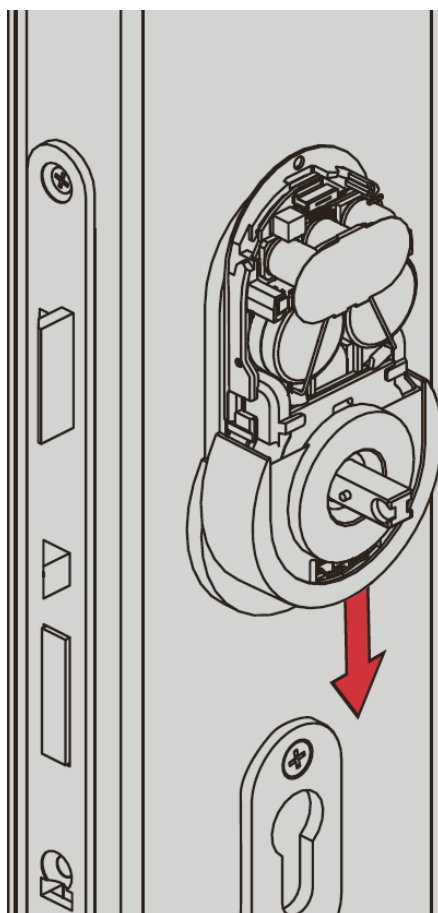

5. Screw the fitting tight (PH1, torque: 0.8 Nm).

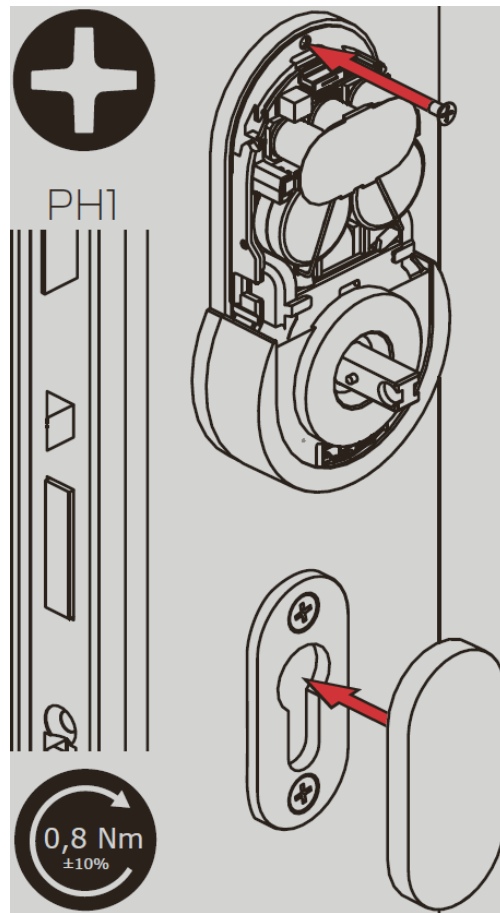

6. Replace the outer escutcheon base cover.

7. Attach the outer handle.

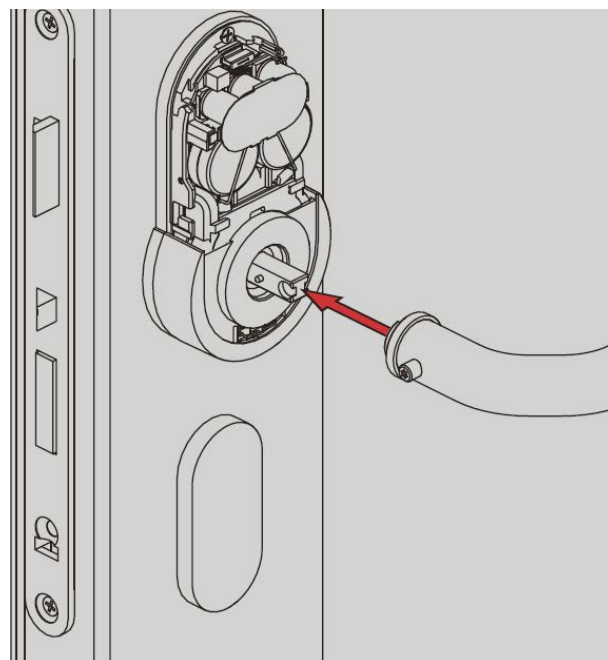

8. Put on the outer cover.



↳ Outer fitting is mounted.

Prepare the square

Door thickness (S, M, L or X) and ring position				
	Notch 1	Notch 2	Notch 3	Notch 4
S	38-43 mm	43-48 mm	48-53 mm	53-58 mm
M	58-63 mm	63-68 mm	68-73 mm	73-78 mm
L	78-83 mm	83-88 mm	88-93 mm	93-98 mm
X	Ring is not used.			

■ Slide the ring onto the correct notch of the square.

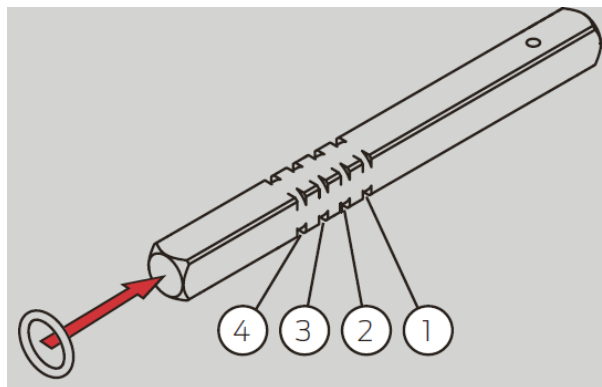

Door thickness to ring position				
Groove #	1	2	3	4
S	38-43	43-48	48-53	53-58
M	58-63	63-68	68-73	73-78
L	78-83	83-88	88-93	93-98
XL	no ring			

↳ Square is prepared.

Mount square and dummy cylinder

1. Insert the square with the side facing away from the circlip.

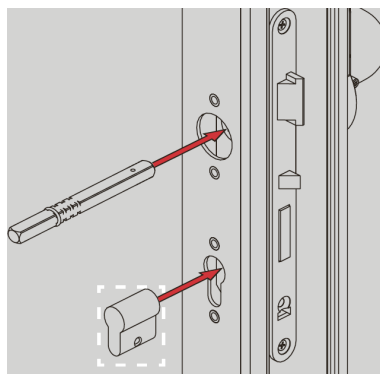

2. If necessary, insert the dummy cylinder.

3. If necessary, screw the dummy cylinder tight (torque: 1.1 Nm).

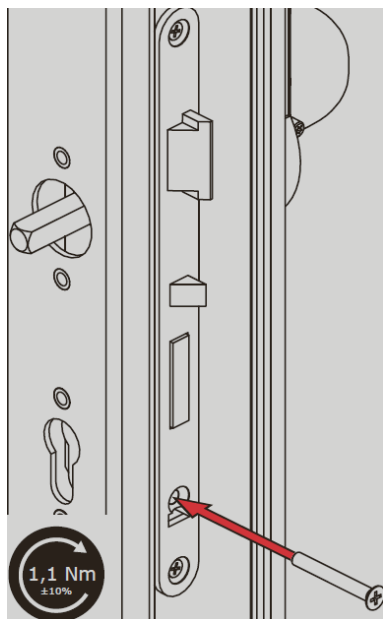

↳ Square and dummy cylinder mounted.

Mounting the inside handle

1. Screw down the inside handle (PH2, torque: 1.1 Nm).

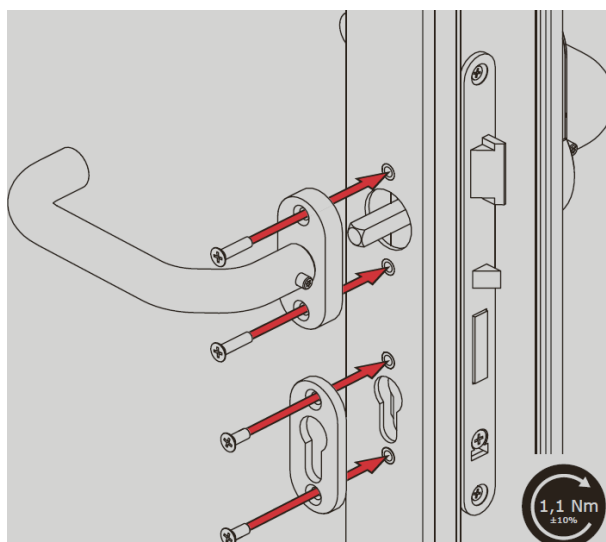

2. Screw the escutcheon base on the inside (PH2, torque: 1.1 Nm).

3. Tighten the set screws on both lever handles (T15, torque: 5.0 Nm).

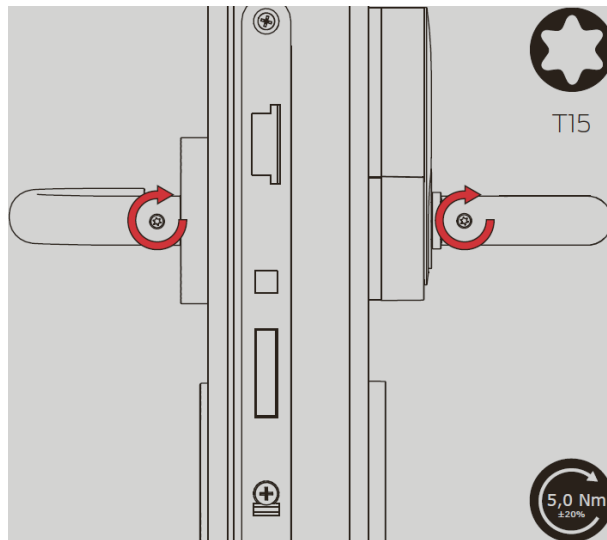

4. Fit the cover of the inside handle.

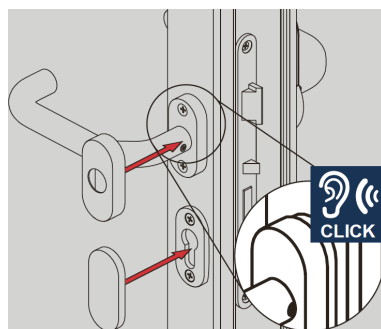

5. Replace the inlay of the inner escutcheon base.

↳ SmartHandle AX variable is fully assembled.

7.5 Variant A4 (Panic bar)

7.5.1 Package contents (BKS)

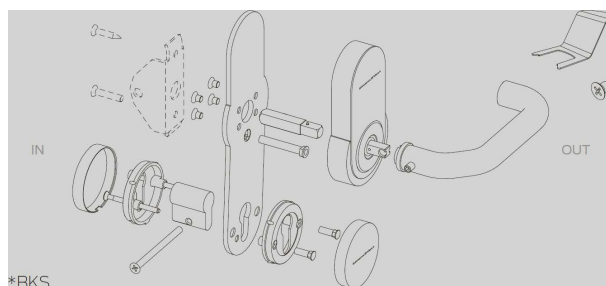

Quantity	Object	
1×	External fitting assembly, incl:	
	4×	Battery (CR2450)
	1×	Inlay
1×	Exterior handle, incl:	
	1×	Headless screw
1×	Adapter plate (pre-bent)	
1×	Spacer sleeve for adapter plate with square head	
5×	Screw for mounting the fitting to the adapter plate (1× reserve)	
2×	Cylinder escutcheon base with opening	
2×	Sleeve nut	
2×	Screw for connecting the escutcheon bases	
2×	Escutcheon covers for cylinders	
1×	Spindle	
1×	Dummy cylinders	
1×	Fastening screw for blind cylinder	
1×	Installation tool	
1×	Quick guide with integrated drilling template	

You also need the following (to be ordered from BKS or included in the scope of delivery of your panic bar):

Quantity	Object
1×	Support plate for panic bar attachment
1×	Screw for fastening to adapter plate (bolt nut as counterpart) Depending on the door thickness Please order at BKS.
1×	Wood screw for fixing the support plate to the door

7.5.2 Package contents (CISA)

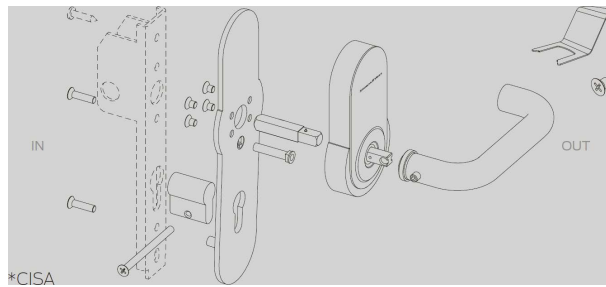

Quantity	Object	
1×	External fitting assembly, incl:	
	4×	Battery (CR2450)
	1×	Inlay
1×	Exterior handle, incl:	
	1×	Headless screw
1×	Adapter plate (pre-bent) with welded-on sleeve nut	
1×	Spacer sleeve for adapter plate with square head	
5×	Screw for mounting the fitting to the adapter plate (1× reserve)	
2×	Screw for connecting the CISA hardware to the adapter plate	
1×	Spindle	
1×	Dummy cylinders	
1×	Fastening screw for blind cylinder	
1×	Installation tool	
1×	Quick guide with integrated drilling template	

You will also need the following (supplied with your panic bar):

Quantity	Object
1×	Support plate for panic bar attachment
1×	Wood screw for fixing the support plate to the door

7.5.3 Tools

You require the following tools for installation:

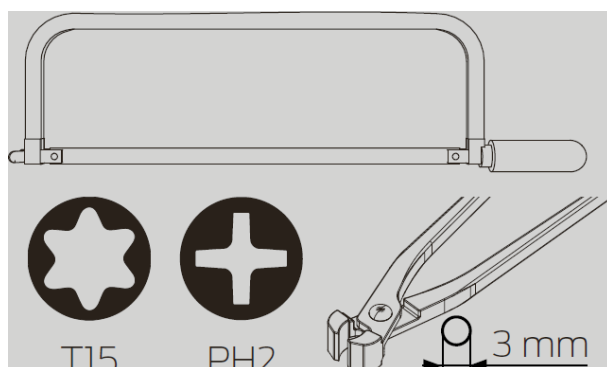
**NOTE****Use saw instead of pliers for shortening**

If no suitable pliers are available to shorten the screws, you can alternatively use a hacksaw.

- T15 screwdriver
- PH2 screwdriver
- Suitable pliers for shortening the screws, e.g. mechanic's nippers
- Hacksaw for shortening the square

7.5.4 Procedure (BKS)

Preparing drill holes

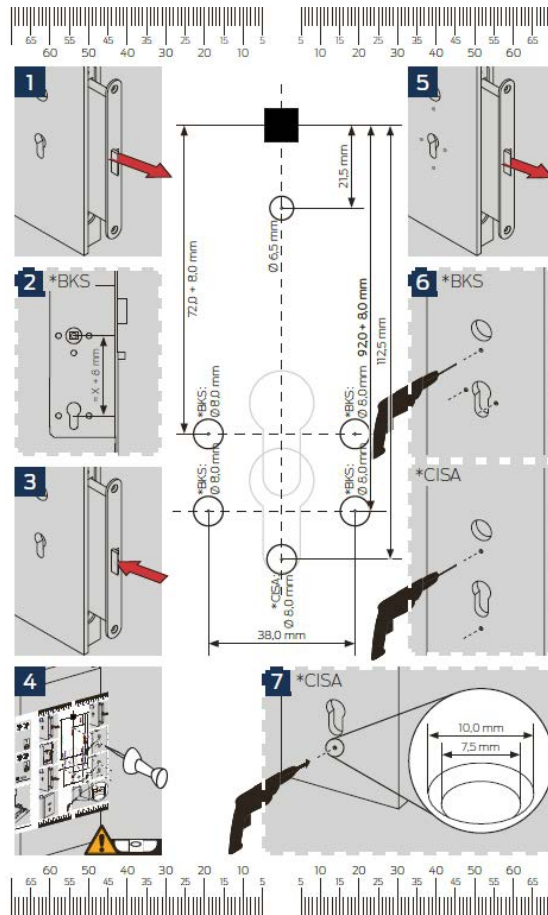

1. Remove the mortise lock.

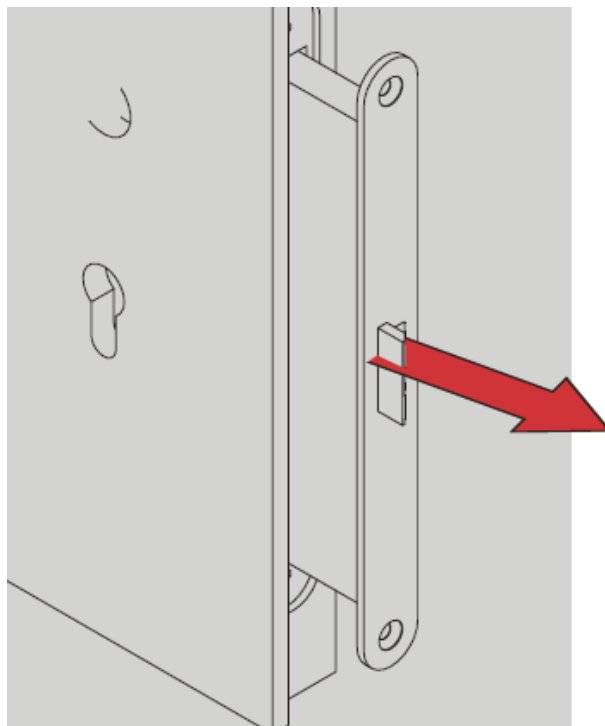

2. Measure the distance between the mounting holes of your mortise lock (distance).

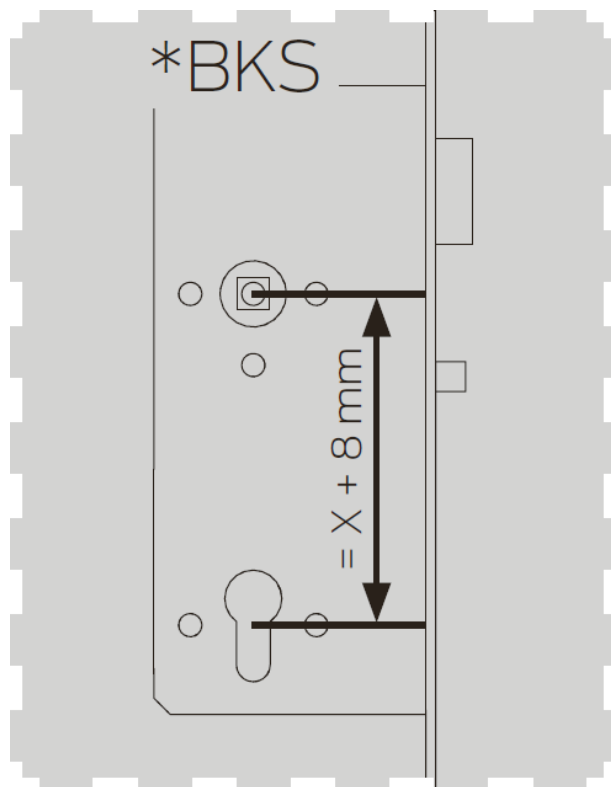

3. Slide the mortise lock back into the door.



4. Insert the square into the mortise lock.

- Using the square and the recess in the drilling template, position the drilling template on the door.

IMPORTANT

Horizontal alignment required

The drill holes must be aligned horizontally.

- Use the printed scale to ensure that the drilling template is aligned horizontally (equal distances).

- Select the correct drill holes for the distance of your mortise lock (72+8 mm or 92+8 mm).
- Use a pointed object (e.g. pin needle) to pierce the position of the BKS drill holes in the door.

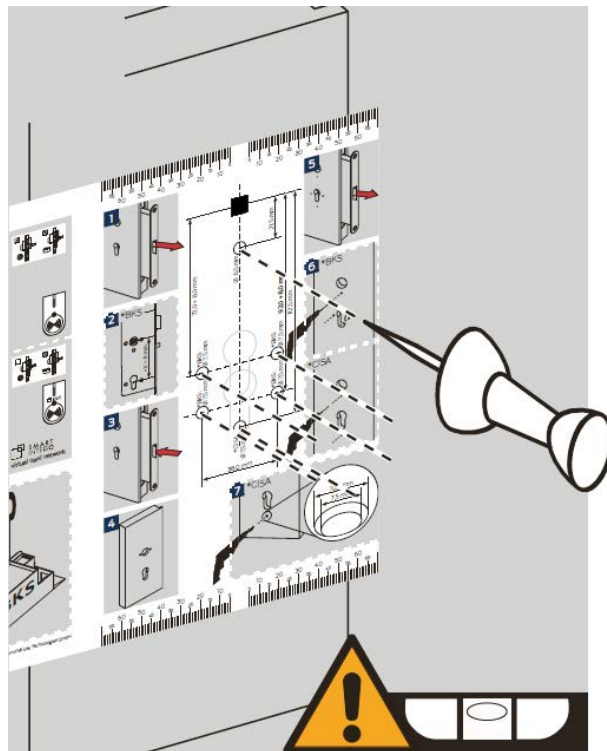

- Remove the drilling template.
- Remove the square.
- Remove the mortise lock.

11. Drill the holes in the door (BKS-specific: \varnothing 8.0 mm or independent of the variant: \varnothing 6.5 mm).

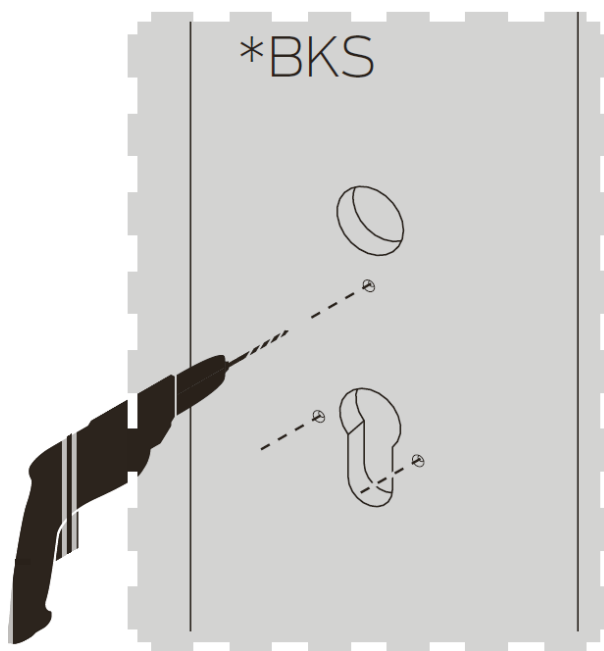

12. Reassemble the mortise lock.
↳ The drill holes are prepared.

Programme



NOTE

Duration of initial programming

A large amount of data is transferred during initial programming. The data transfer speed is significantly higher with a SmartStick AX or a SmartCD.MP (and the programming time is therefore shorter).

- If possible, use a SmartStick AX or a SmartCD.MP for initial programming.

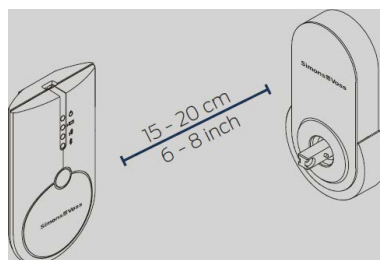

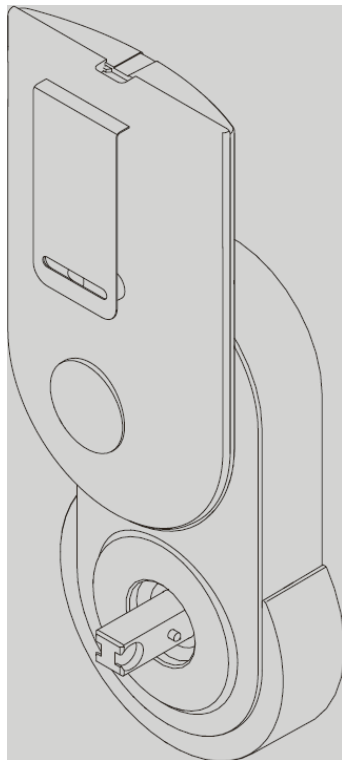

- ✓ Locking device added in LSM software.
 - ✓ LSM software launched.
 - ✓ Programming device connected.
1. Position the programming device.
 2. Programme the SmartHandle AX (see , quick guide or LSM manual for details).
- ↳ SmartHandle AX is programmed.

Prepare square and screws

1. Measure the thickness of your door.

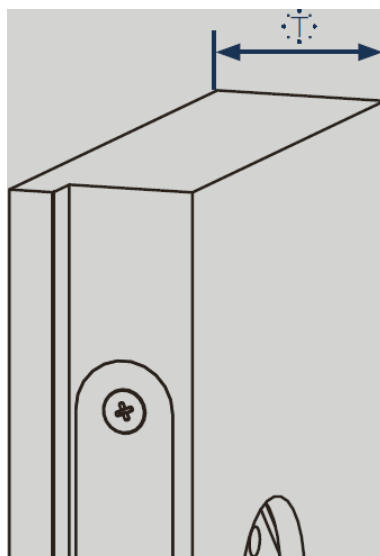

- Use a saw to shorten the supplied screws and the square (screws: door thickness+12 mm, square_(panic bar): door thickness+23 mm/ square_(panic bar): door thickness+32 mm).

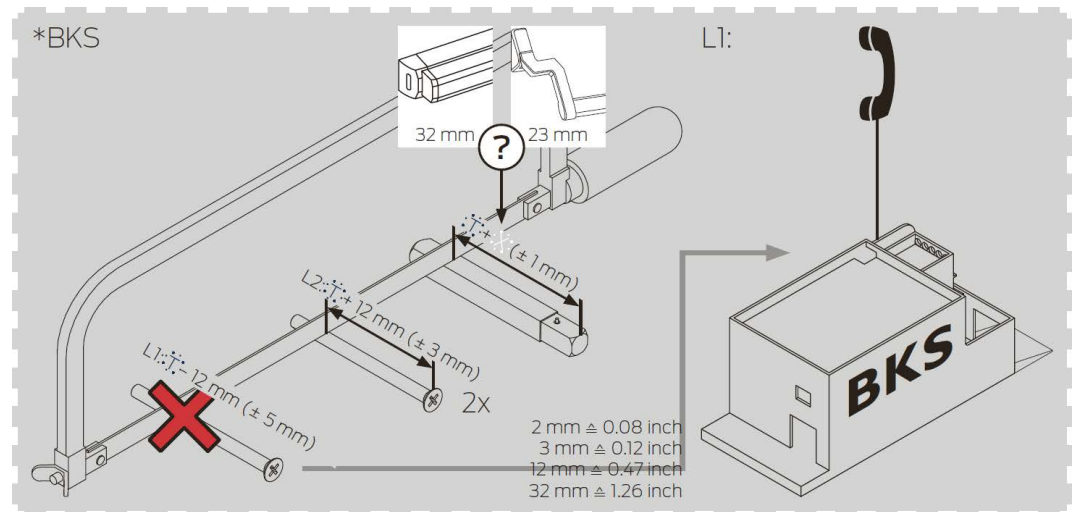

↳ Square and screws prepared.

The L1 screw must meet increased requirements and is not included in the scope of delivery. Order this screw directly from BKS.

Preparing the fitting

- Insert the spacer sleeve into the adapter plate.

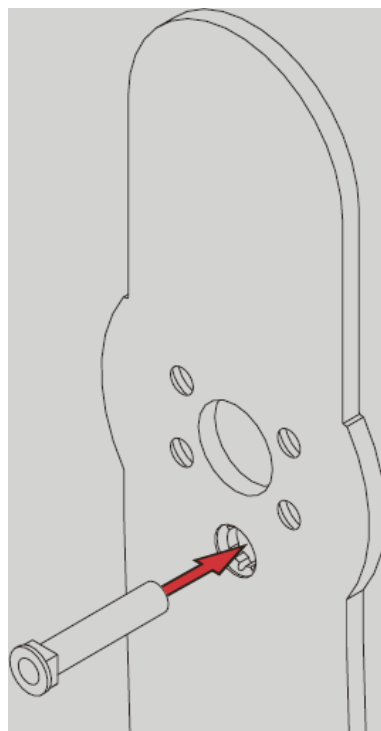

- Place the fitting against the adapter plate from the opposite side.

**NOTE****Aligning the holes of the fitting and adapter plate**

Offset holes in the adapter plate and threaded mountings in the fitting make installation more difficult.

- Align the holes in the adapter plate and the threaded holders in the fitting.

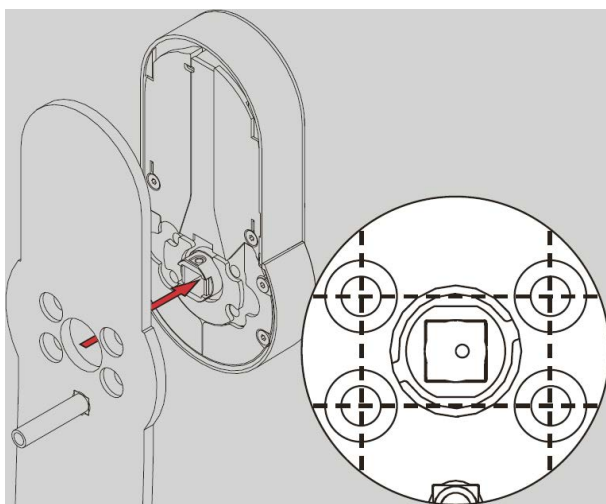

3. Tighten the fitting crosswise with the first two fixing screws (PH2, torque: 1.1 Nm).

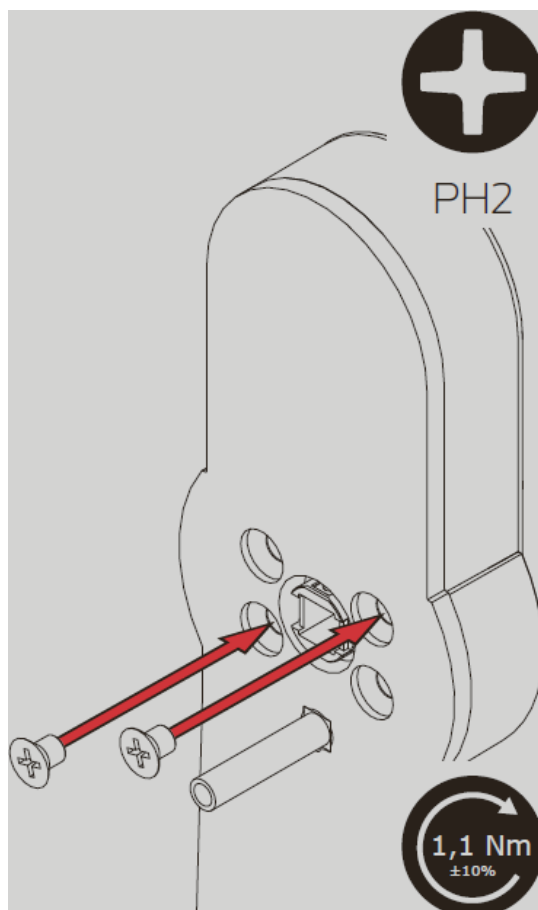

4. Tighten the other two screws crosswise (PH2, torque: 1.1 Nm).

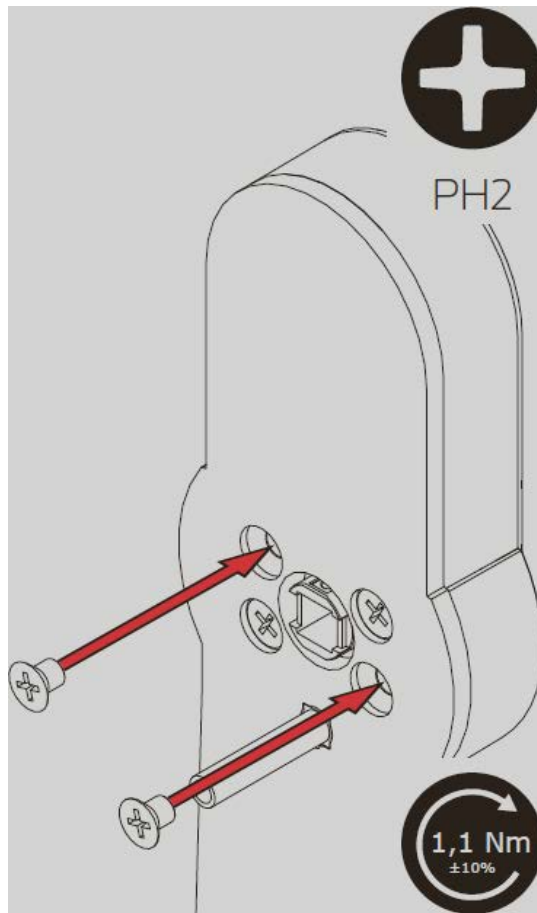

5. Slide the square into the square socket of the fitting.

Mount the fitting and fix the support plate

1. Insert the prepared fitting into the door from the outside.

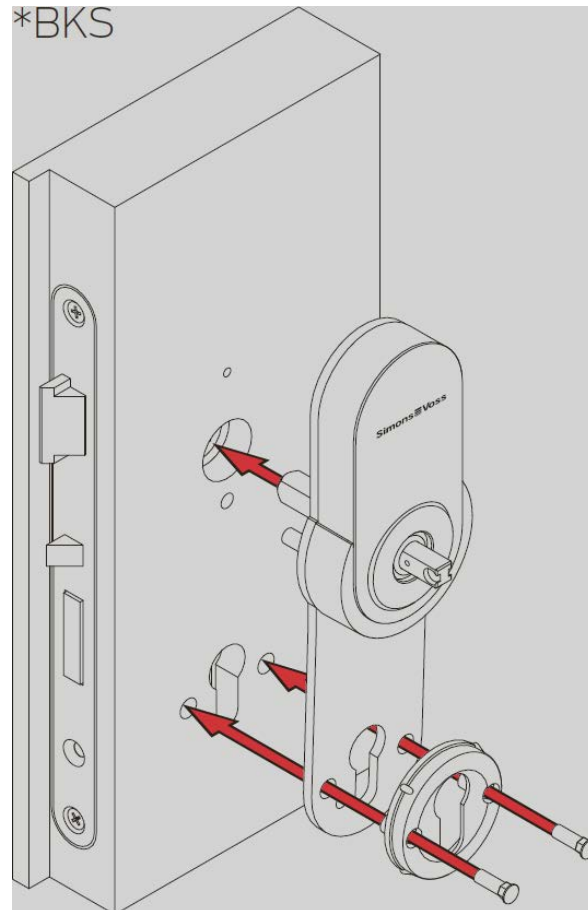

2. Insert the escutcheon base onto the adapter plate.
3. Insert the two sleeve nuts into the escutcheon base.
4. Tighten the BKS mounting (wood screw and L1 screw).



NOTE

Third party product with own documentation

The panic bar holder is a third-party product.

- Please follow the manufacturer's instructions and safety instructions.

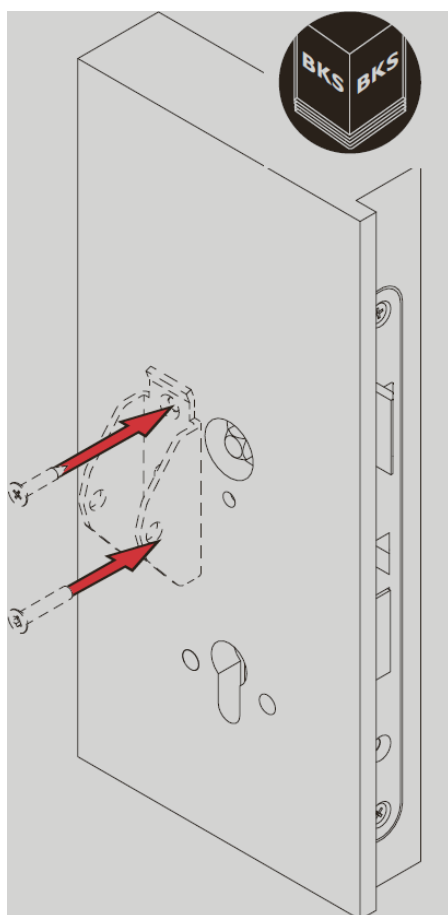

5. Screw the escutcheon base tight on the inside (L2 screws with PH2, 1.1 Nm).

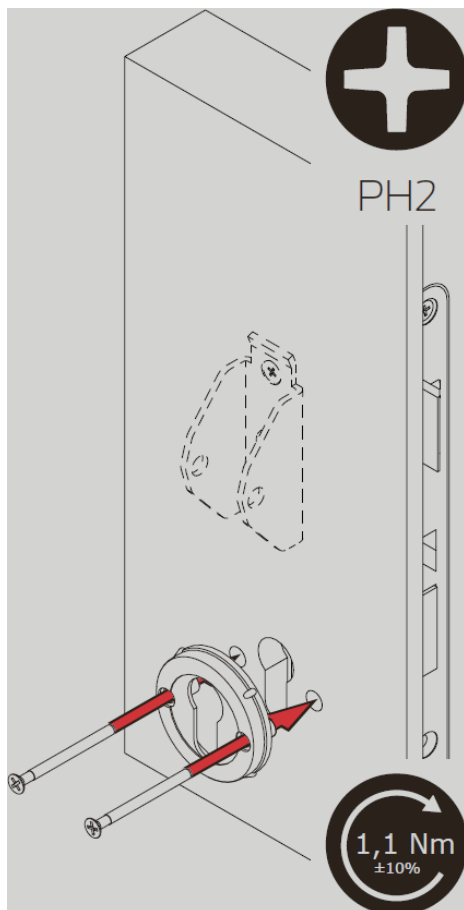

↳ The fitting is fastened.

Mount dummy cylinder and handle

1. Insert the dummy cylinder.

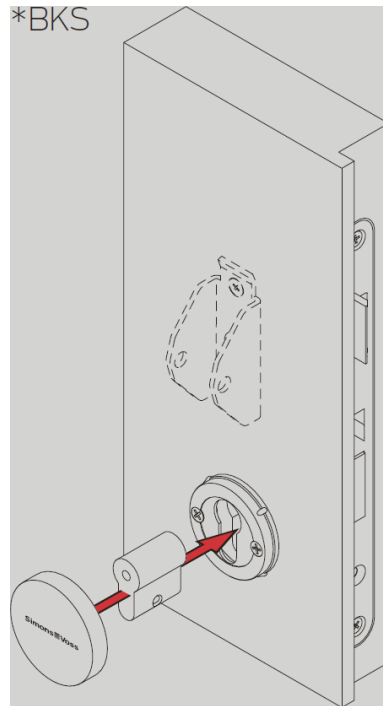

2. Insert the escutcheon cover on the inner escutcheon base.
3. Push the handle onto the fitting.

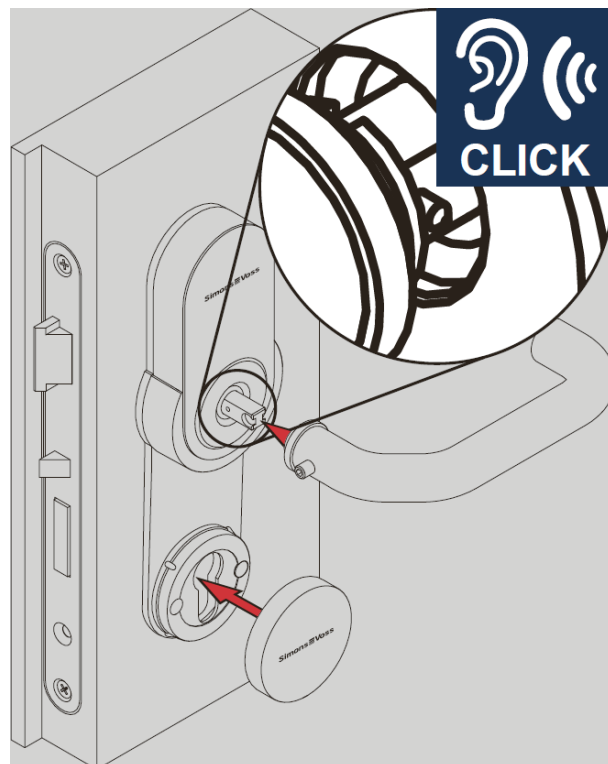

4. Push the escutcheon cover onto the outer escutcheon base.

5. Tighten the handle (T15, torque: 5.0 Nm).

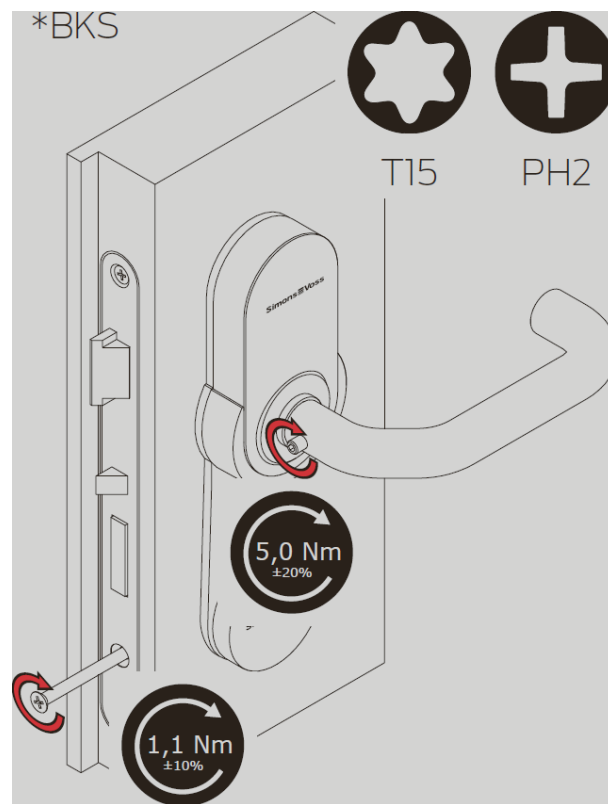

6. Screw the dummy cylinder tight (PH2, torque: 1.1 Nm).

↳ SmartHandle AX completely assembled.

Mounting the panic bar



NOTE

Third party product with own documentation

The panic bar holder is a third-party product.

■ Please follow the manufacturer's instructions and safety instructions.

7.5.5 Procedure (CISA)

Preparing drill holes

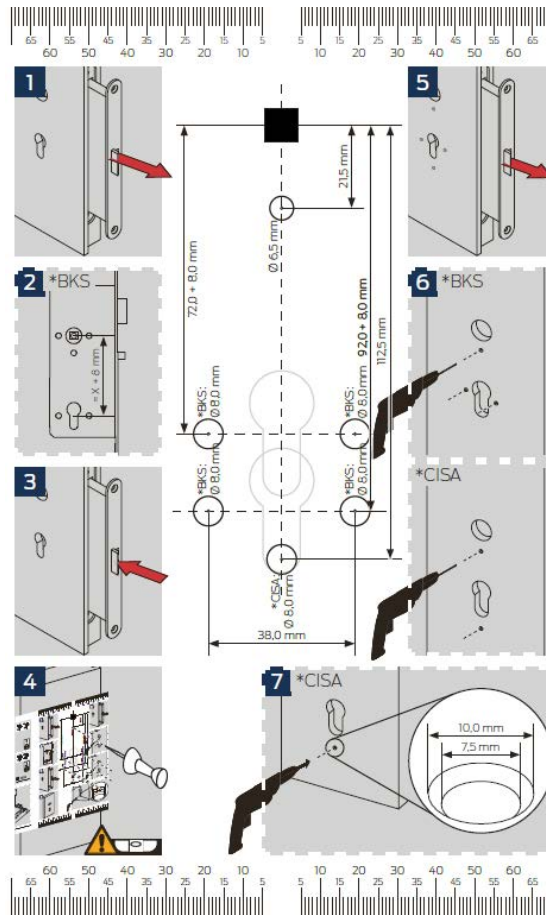

1. Insert the square into the mortise lock.
2. Using the square and the recess in the drilling template, position the drilling template on the door.

IMPORTANT**Horizontal alignment required**

The drill holes must be aligned horizontally.

- Use the printed scale to ensure that the drilling template is aligned horizontally (equal distances).

3. Use a pointed object (e.g. pin needle) to pierce the position of the CISA drill holes in the door.

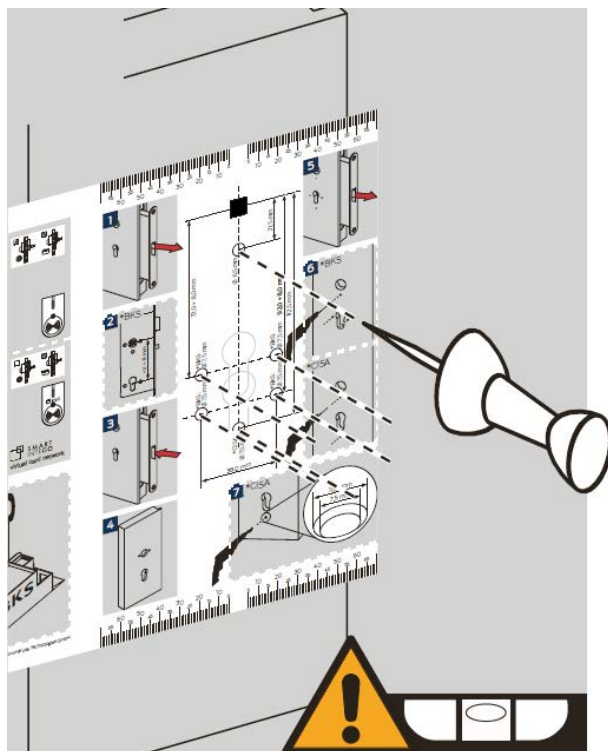

4. Remove the drilling template.
5. Remove the square.
6. Remove the mortise lock.
7. Drill the holes in the door (CISA-specific: \varnothing 8.0 mm or independent of the variant: \varnothing 6.5 mm).

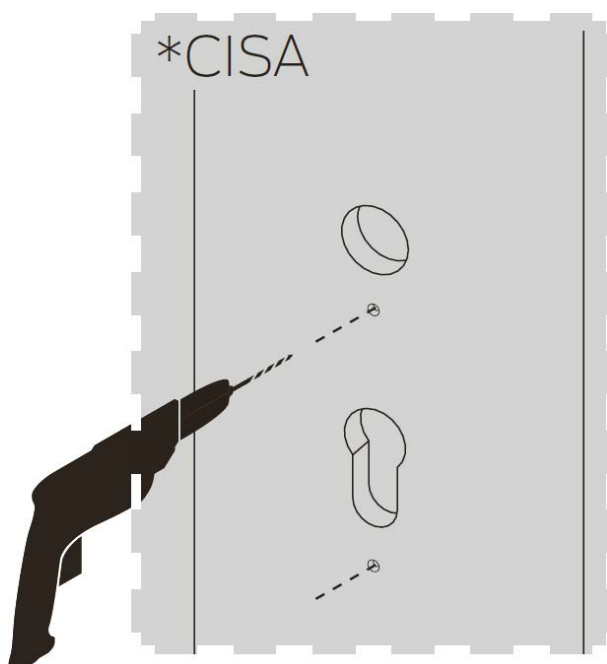

8. Countersink the boreholes as shown with a 90° countersink.

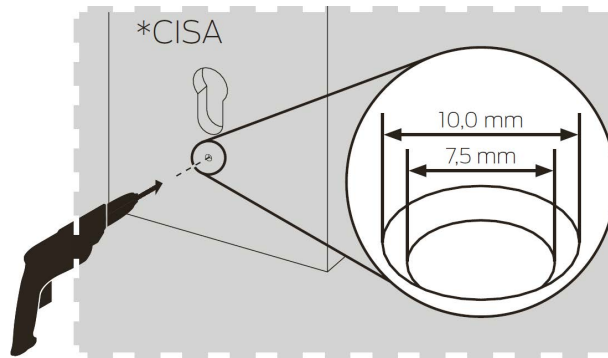

9. Reassemble the mortise lock.

↳ The drill holes are prepared.

Programme



NOTE

Duration of initial programming

A large amount of data is transferred during initial programming. The data transfer speed is significantly higher with a SmartStick AX or a SmartCD.MP (and the programming time is therefore shorter).

- If possible, use a SmartStick AX or a SmartCD.MP for initial programming.

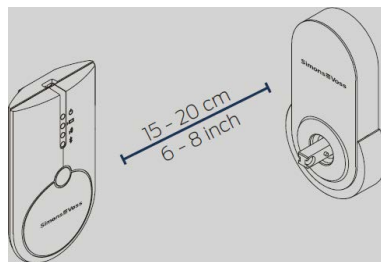

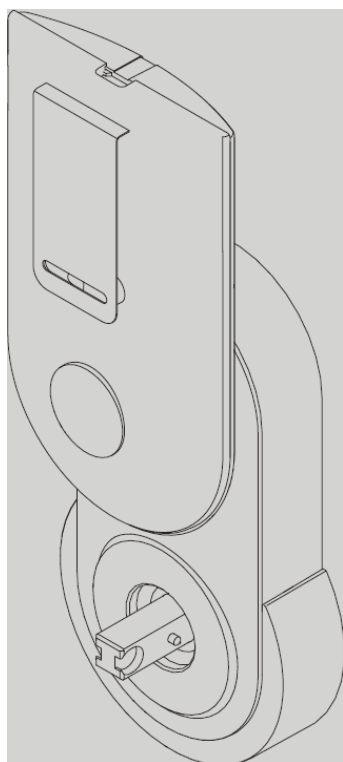

- ✓ Locking device added in LSM software.
 - ✓ LSM software launched.
 - ✓ Programming device connected.
1. Position the programming device.
 2. Programme the SmartHandle AX (see , quick guide or LSM manual for details).
- ↳ SmartHandle AX is programmed.

Prepare square and screws

1. Measure the thickness of your door.

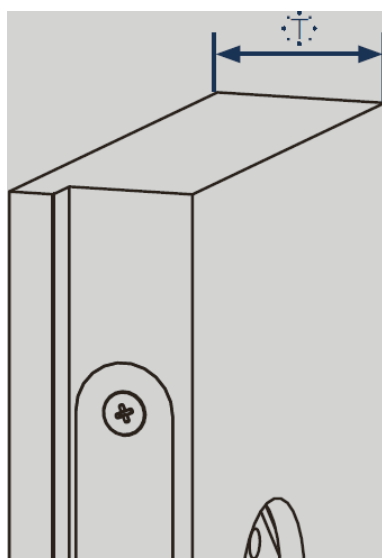

2. Use a saw to shorten the screws and the square (screws: Door thickness-10 mm, square: door thickness+14.5 mm).

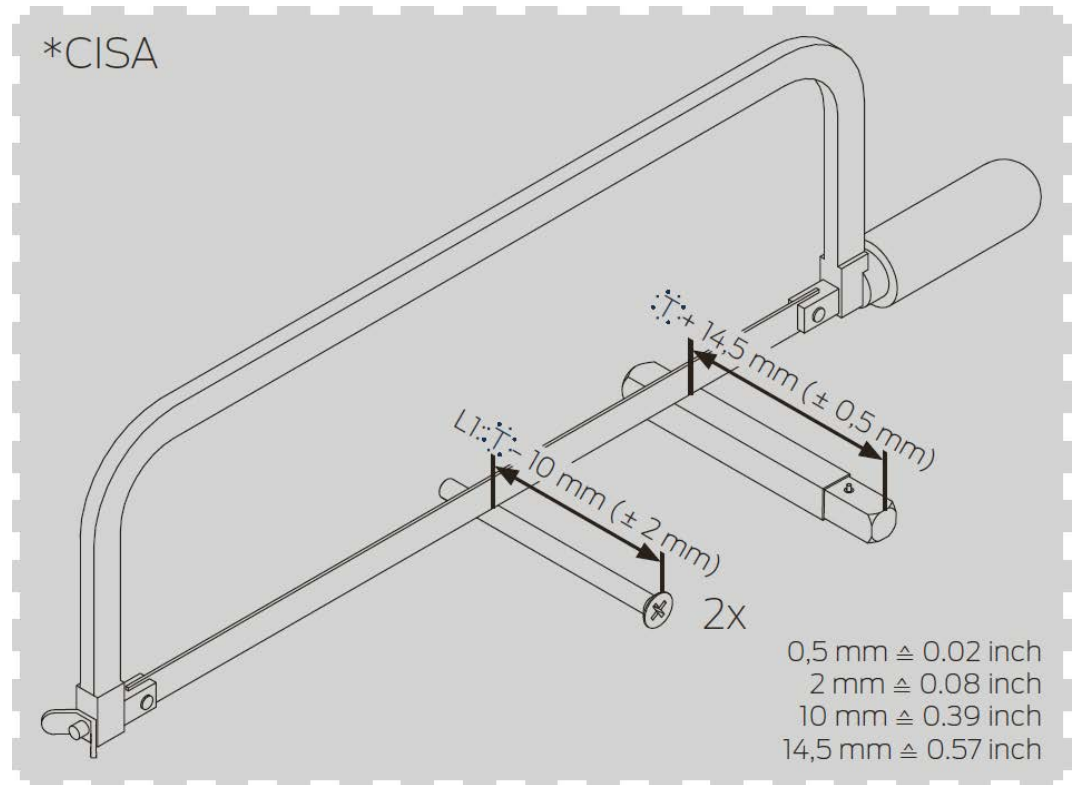

↳ Square and screws prepared.

Preparing the fitting

1. Insert the spacer sleeve into the adapter plate.

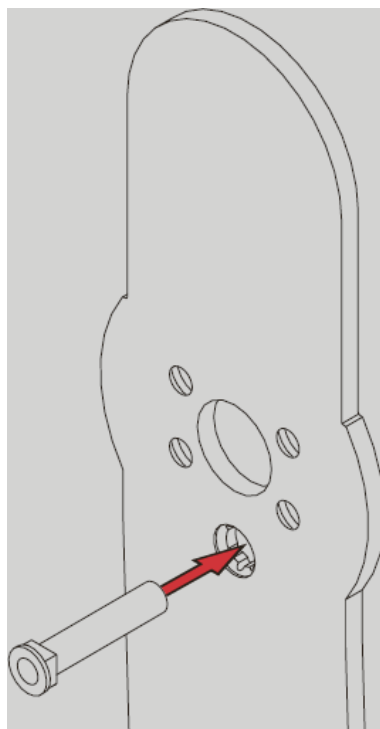

2. Place the fitting against the adapter plate from the opposite side.

**NOTE****Aligning the holes of the fitting and adapter plate**

Offset holes in the adapter plate and threaded mountings in the fitting make installation more difficult.

- Align the holes in the adapter plate and the threaded holders in the fitting.

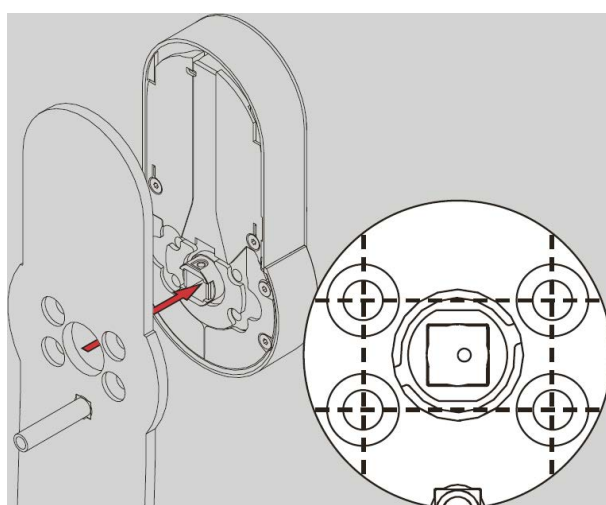

3. Tighten the fitting crosswise with the first two fixing screws (PH2, torque: 1.1 Nm).

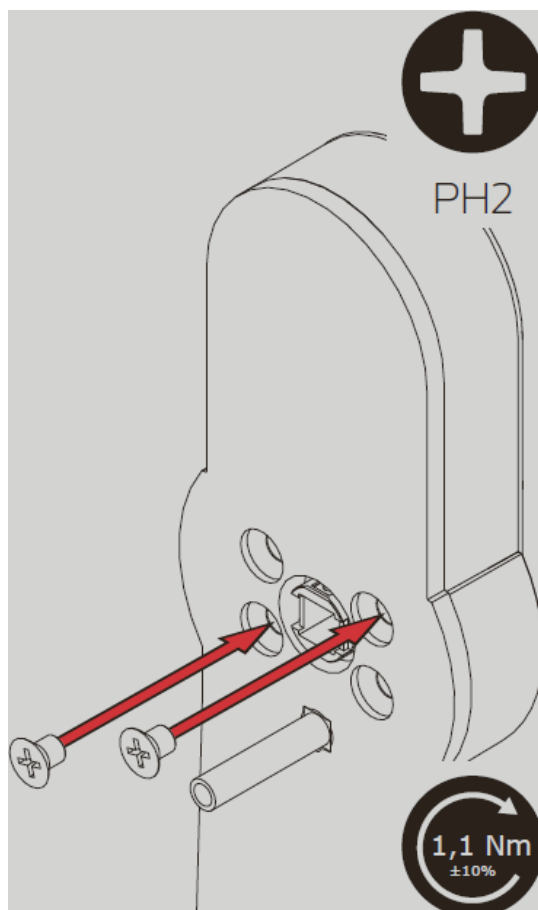

4. Tighten the other two screws crosswise (PH2, torque: 1.1 Nm).

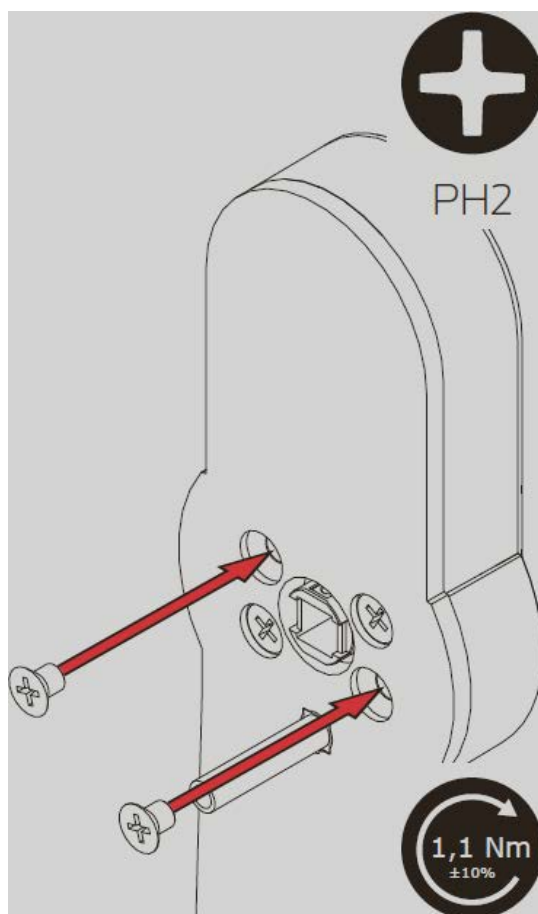

5. Slide the square into the square socket of the fitting.

Mount the fitting and fix the support plate

1. Insert the prepared fitting into the door from the outside.



2. Tighten the CISA mount with the centre mounting screw.

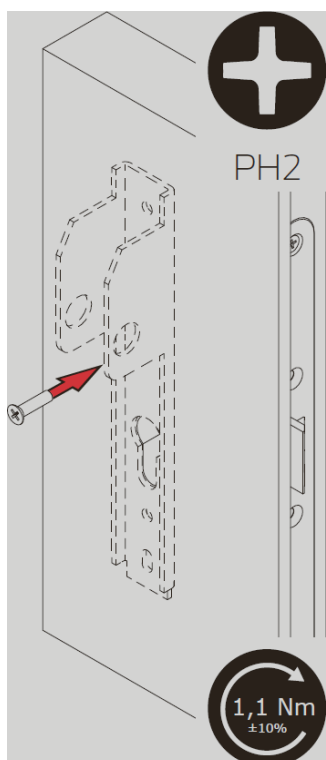

3. Tighten the bottom mounting screw.

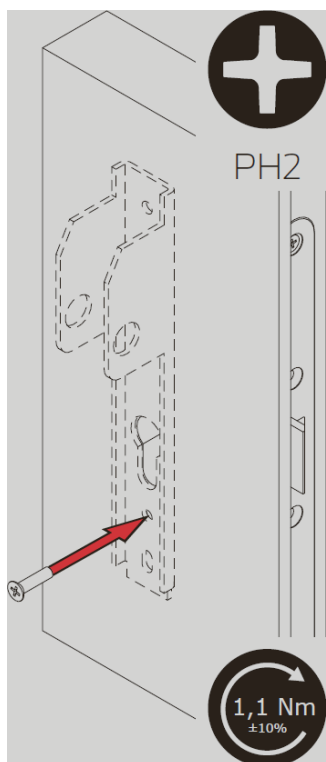

4. Tighten the upper fastening screw (wood screw).

**NOTE****Third party product with own documentation**

The panic bar holder is a third-party product.

- Please follow the manufacturer's instructions and safety instructions.

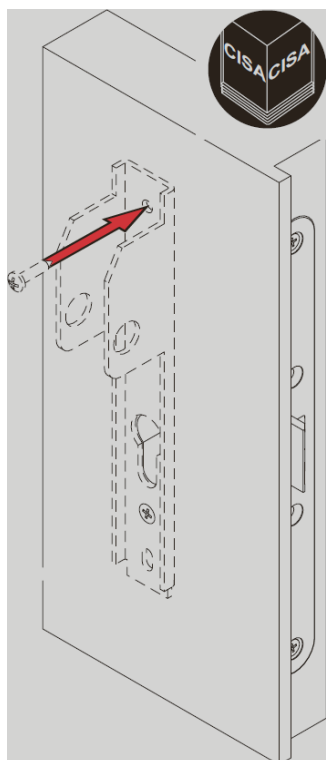

↳ The fitting is fastened.

Mount dummy cylinder and handle

1. Push the handle onto the fitting.

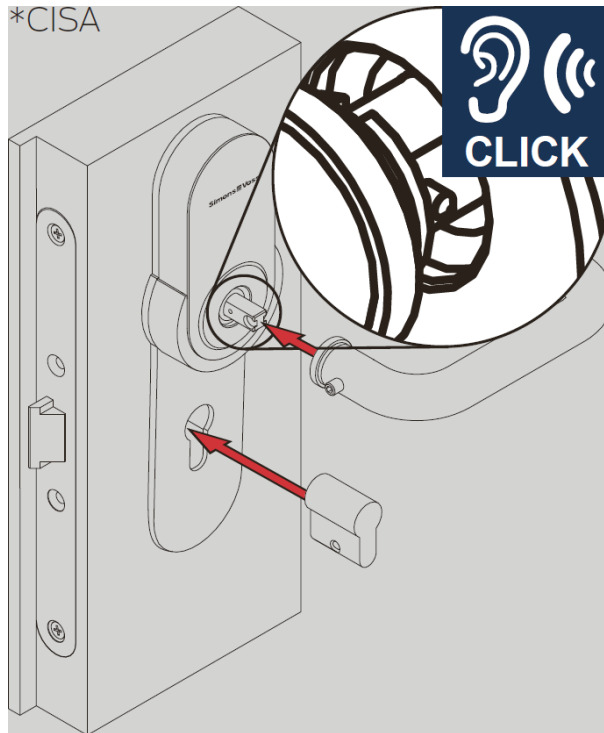

2. Insert the dummy cylinder.
3. Tighten the handle (T15, torque: 5.0 Nm).

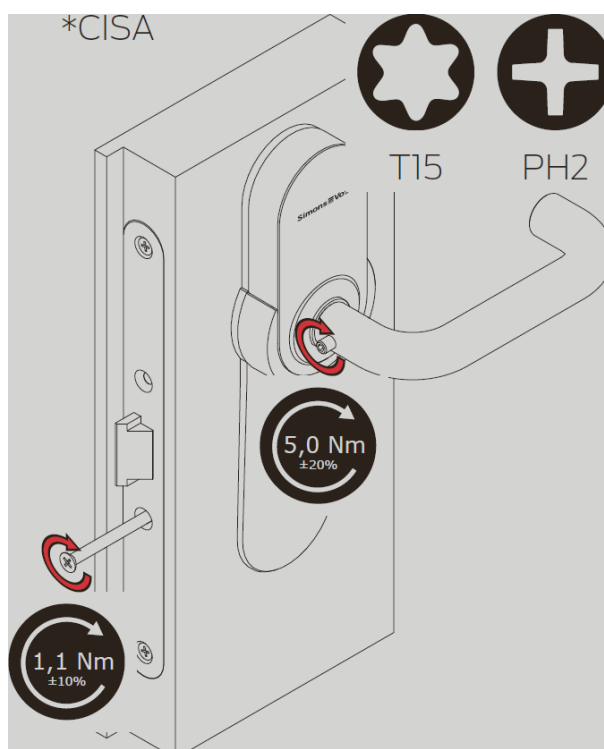

4. Screw the dummy cylinder tight (PH2, torque: 1.1 Nm).
- ↳ SmartHandle AX completely assembled.

Mounting the panic bar



NOTE

Third party product with own documentation

The panic bar holder is a third-party product.

- Please follow the manufacturer's instructions and safety instructions.

7.5.6 Information for panic bar

The adapter plate for the fitting is pre-bent. The pretensioning ensures the frictional connection to the door after installation.

The scope of delivery includes a spare screw. You can use this screw if you have lost a screw for mounting the adapter plate.

7.6 DS variant (reader on both sides)

7.6.1 Contents of packaging

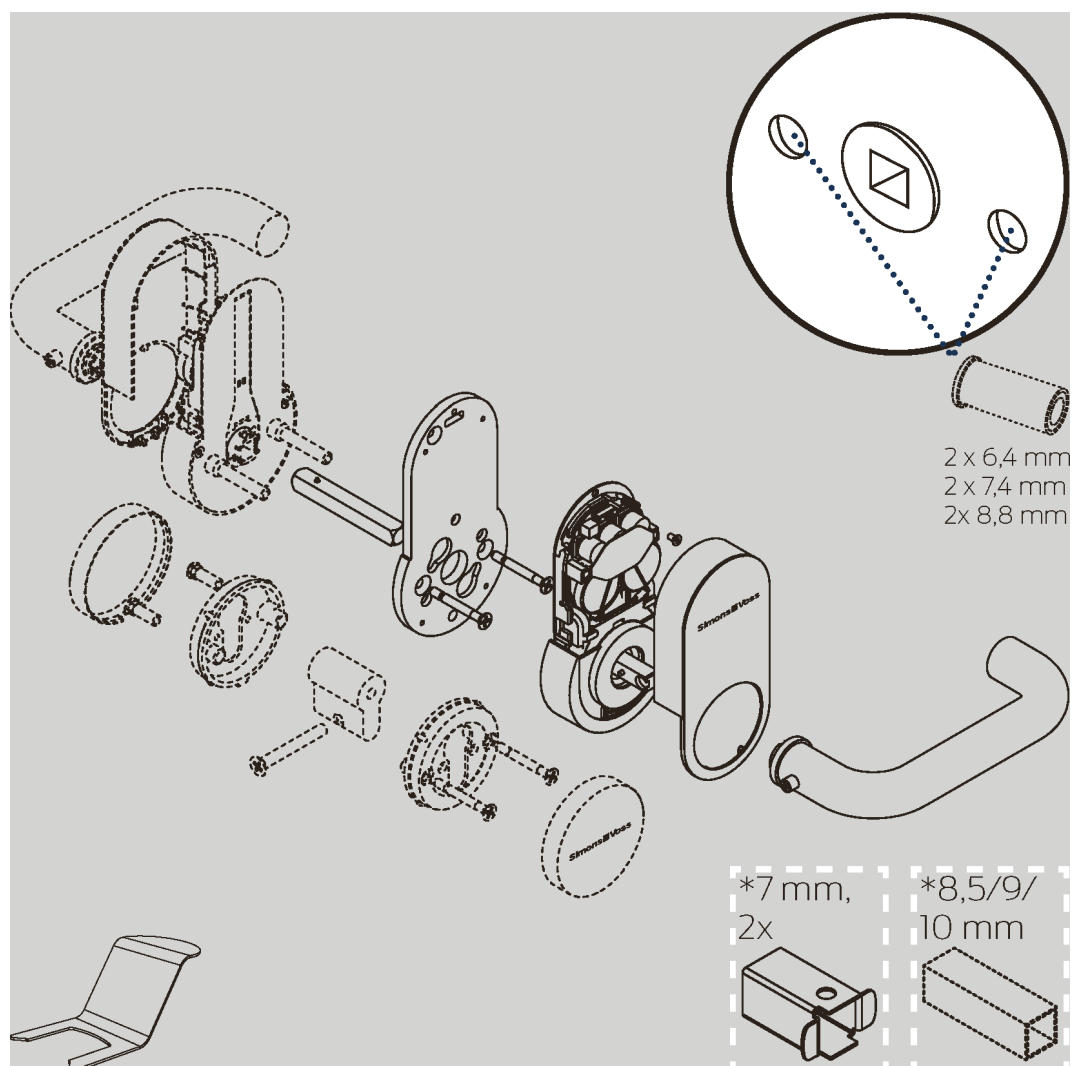

Quantity	Object	
1×	Internal fittings assembly, incl:	
	4×	Battery (CR2450)
	1×	Inlay
1×	Interior handle, incl:	
	1×	Headless screw
1×	Adapter plate with non-slip foil	
2×	Screws for adapter plate	
1×	Screw as anti-twist protection	
1×	Spindle	
1×	Installation tool	
1×	Quick guide with integrated drilling template	

All other components are hatched and are included with the SmartHandle AX, which must be ordered separately. Depending on the square ordered, appropriate adapters are included.

7.6.2 Tool

You require the following tools for installation:

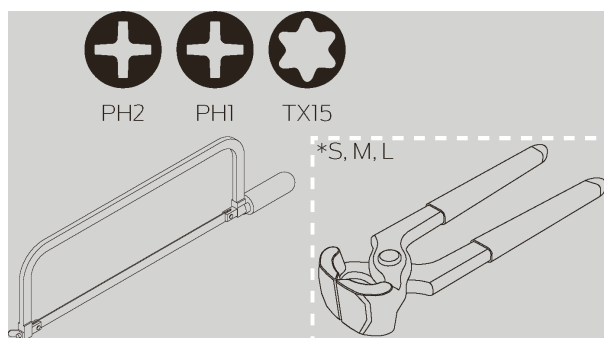

- TX15 screwdriver
- PH2 screwdriver
- PH1 screwdriver
- Saw for shortening the square, e.g. hacksaw
- (S, M or L variant: Pliers for shortening screws)

7.6.3 Procedure

Preparing drill holes

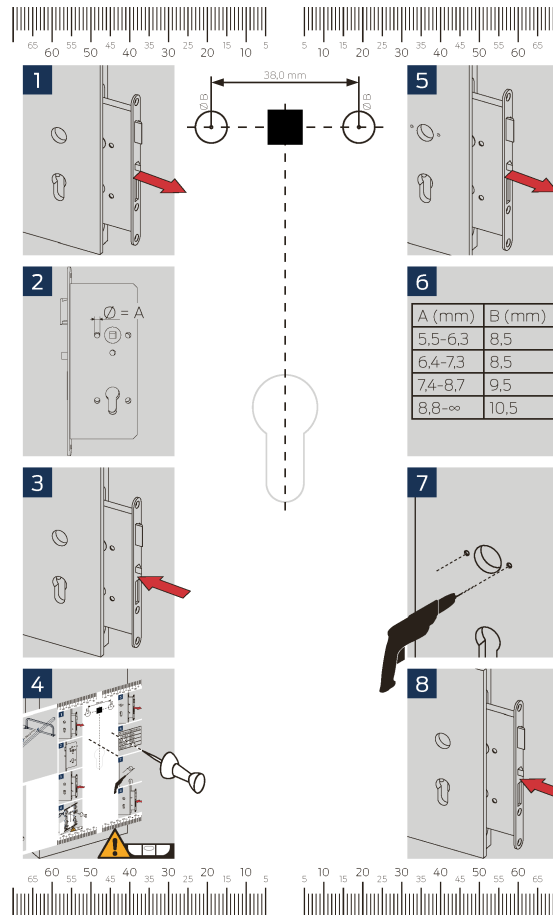

Diameter A	Drill B
5.5 - 6.3 mm	8.5 mm
6.4 - 7.3 mm	8.5 mm
7.4 - 8.7 mm	9.5 mm
8.8 or larger	10.5 mm

1. Pull out the mortise lock.



2. Measure the diameter of the fixing holes on the mortise lock.

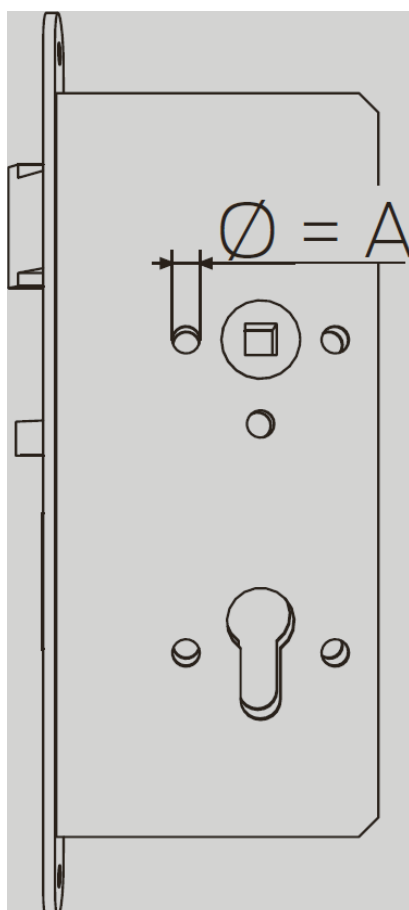

3. Slide the mortise lock back into the door.



4. Insert the square into the mortise lock.
5. Using the square and the recess in the drilling template, position the drilling template on the door.

IMPORTANT

Horizontal alignment required

The drill holes must be aligned horizontally.

- Use the printed scale to ensure that the drilling template is aligned horizontally (equal distances).
-

6. Use a pointed object (e.g. pin needle) to pierce the position of the drill holes in the door.

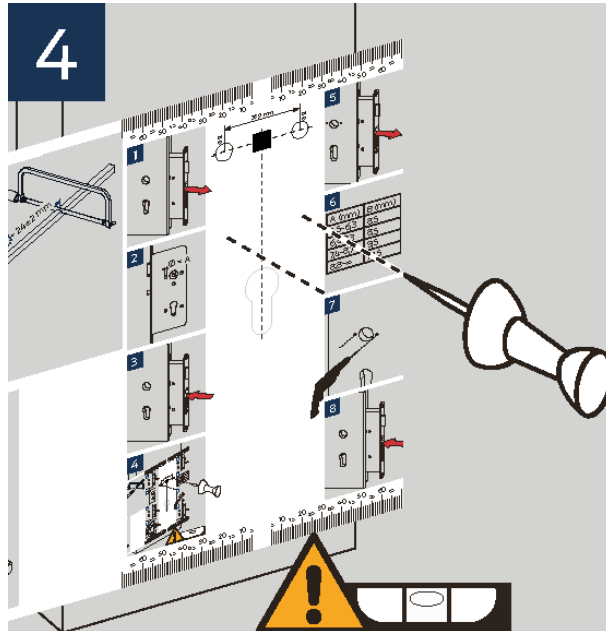

7. Remove the drilling template.
8. Remove the square.
9. Remove the mortise lock.

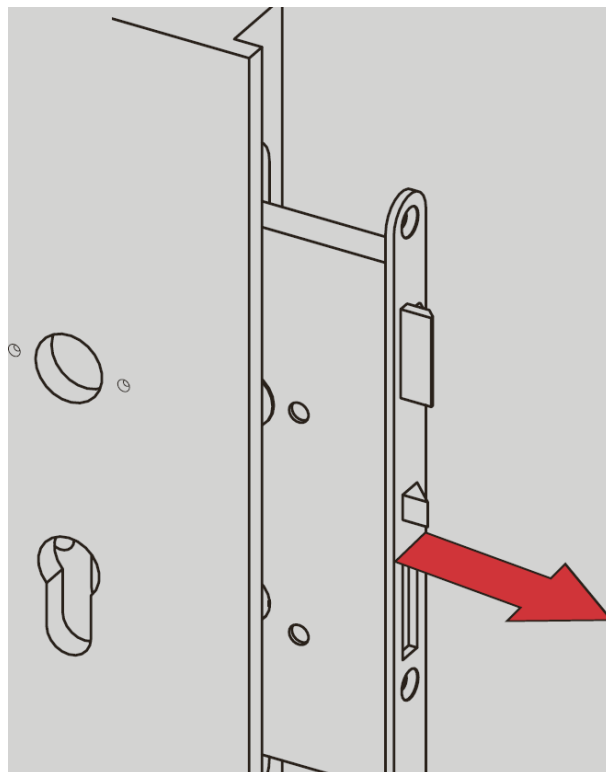

10. Select a suitable drill, depending on the diameter of the mounting holes of your mortise lock (see table).

11. Drill the holes in the door.

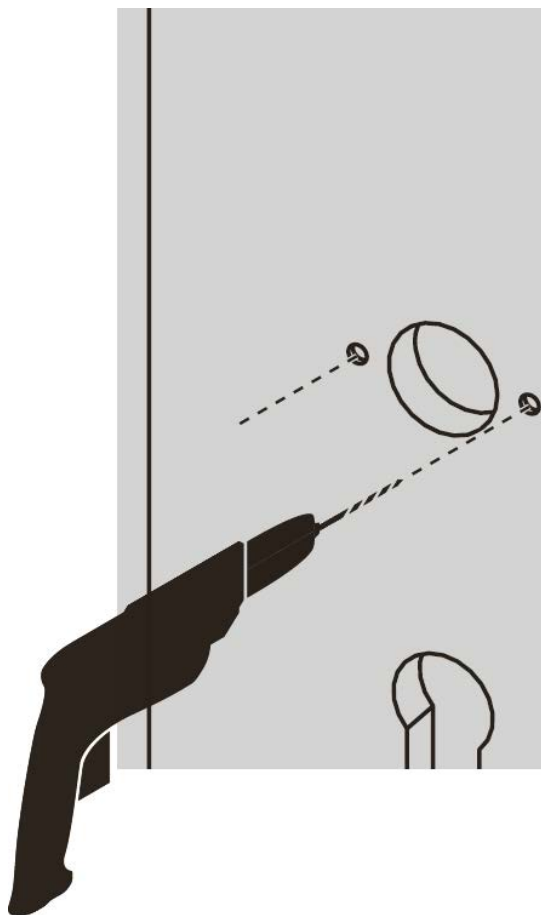

12. Reassemble the mortise lock.



↳ The drill holes are prepared.

Performing programming

Programme both SmartHandle AX.



NOTE

Duration of initial programming

A large amount of data is transferred during initial programming. The data transfer speed is significantly higher with a SmartStick AX or a SmartCD.MP (and the programming time is therefore shorter).

- If possible, use a SmartStick AX or a SmartCD.MP for initial programming.

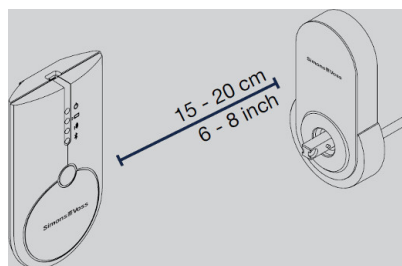

Fig. 5: Programming active (SmartCD.G2)

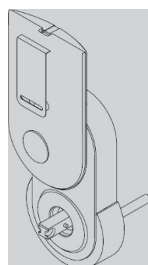

Fig. 6: Programming passive (SmartCD.MP)

- ✓ Locking device added in LSM software.
- ✓ LSM software launched.
- ✓ Programming device connected.

1. Position the programming device.
 2. Programme the SmartHandle AX (see , quick guide or LSM manual for details).
- ↳ SmartHandle AX is programmed.

Shorten screws and square

Screw/square	Length
2× L	T - 11 mm (± 3 mm)
Spindle	T + 24 mm (± 2 mm)

1. Measure the thickness of the door.

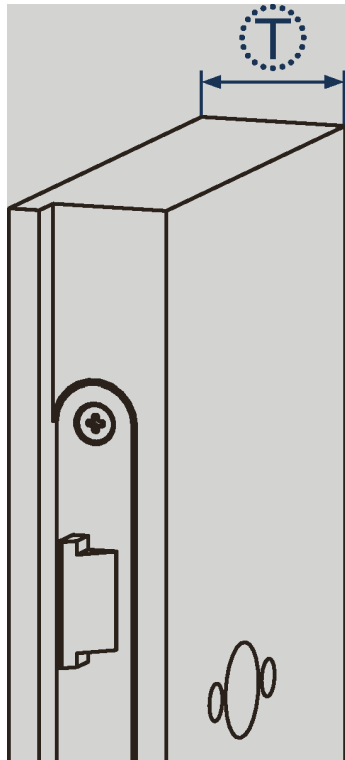

2. Calculate the screw lengths.
3. Select suitable predetermined breaking points that are no more than 3 mm from the calculated length.
4. Separate the predetermined breaking points with pliers.

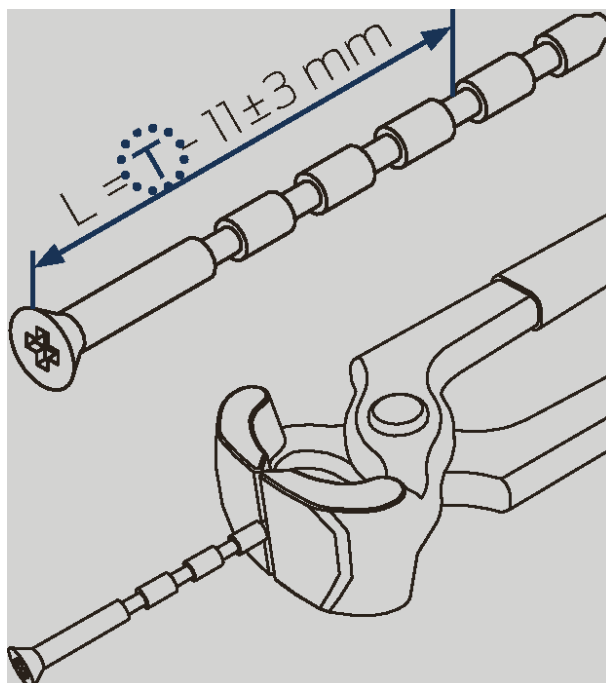

↳ Screws are shortened.

Shorten the square of the extra long version (X)

The square of the extra long version is supplied with 200 mm.

- If you have the extra-long version, you shorten the square yourself with a suitable saw (e.g. hacksaw): Length = door thickness + 58 mm, tolerance ± 1 mm).

1. Assemble the screws, the extension sleeves and the threaded rods.

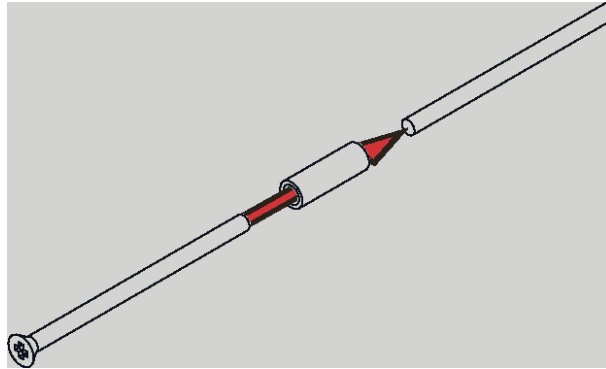

2. Shorten the screws.

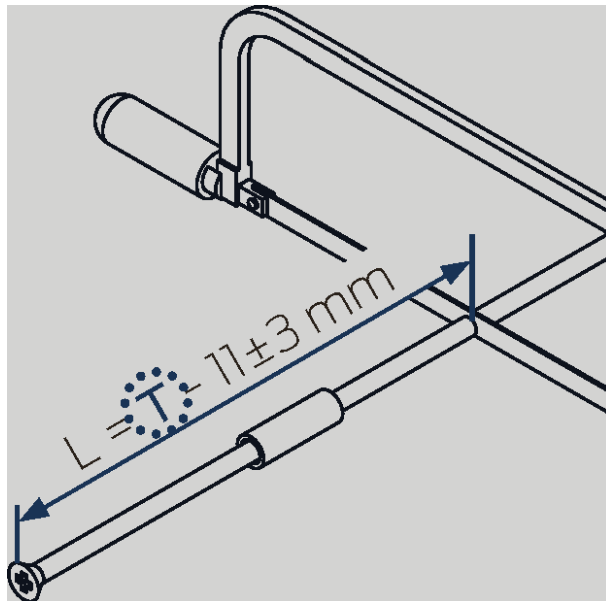

- ↳ Screws of the X-variant are shortened.

Shorten square

- Shorten the square.

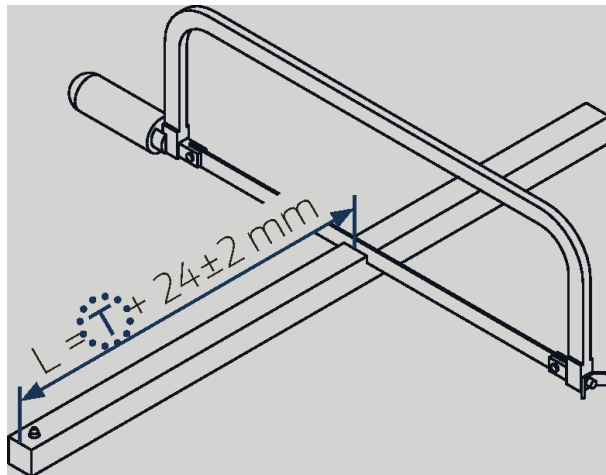

↳ All parts are shortened.

Insert square

7 mm square

The 7 mm square only fits into the 8 mm receptacle of the SmartHandle AX with an adapter shoe (included in the scope of delivery for the 7 mm version).

- ❑ Before mounting the 7 mm square, place the adapter shoe on the square.

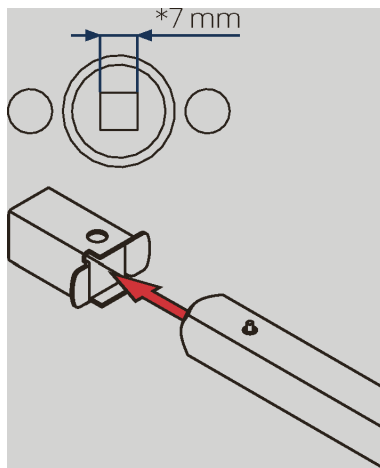

- ❑ Slide the square into the outer assembly of the SmartHandle AX until the pin engages the square.

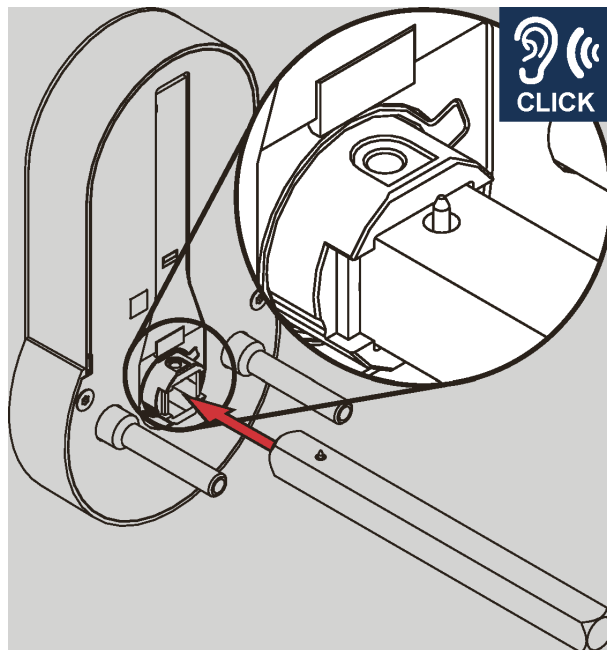

↳ Square is inserted.

Mounting the outer assembly

Square > 8 mm

The SmartHandle AX is supplied with 8 mm square. If the slot of the mortise lock is larger than 8 mm, the square has play.

1. Thicken the square with the push-on sleeve.
2. Use a hammer and centre punch to carefully make a dent in the assembled push-on sleeve.

↳ The slip-on sleeve fits snugly on the square and does not slip easily.

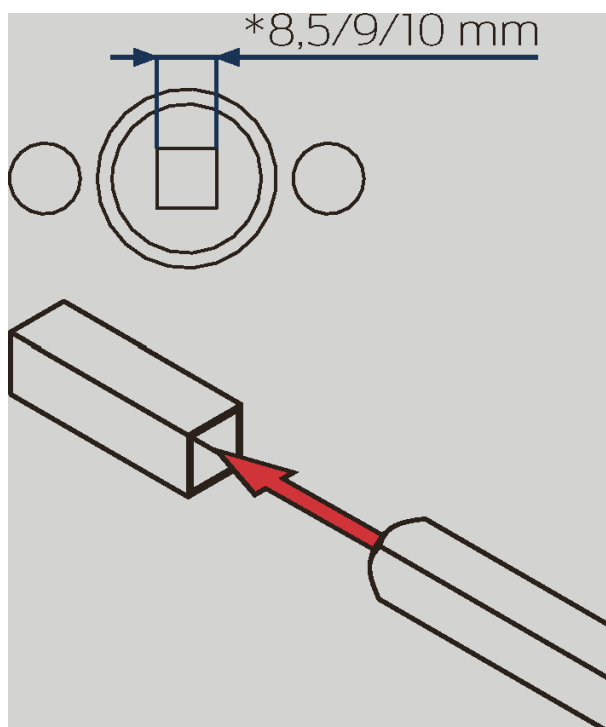

1. Insert the outer assembly with the adapter sleeves and the escutcheon base with the sleeve nuts into the drill holes.

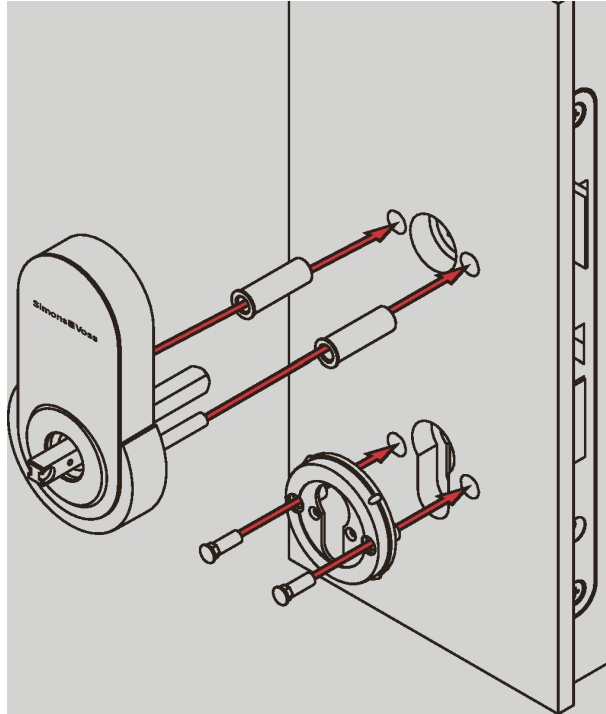

2. On the other side of the door, attach the second escutcheon base and screw it in place.

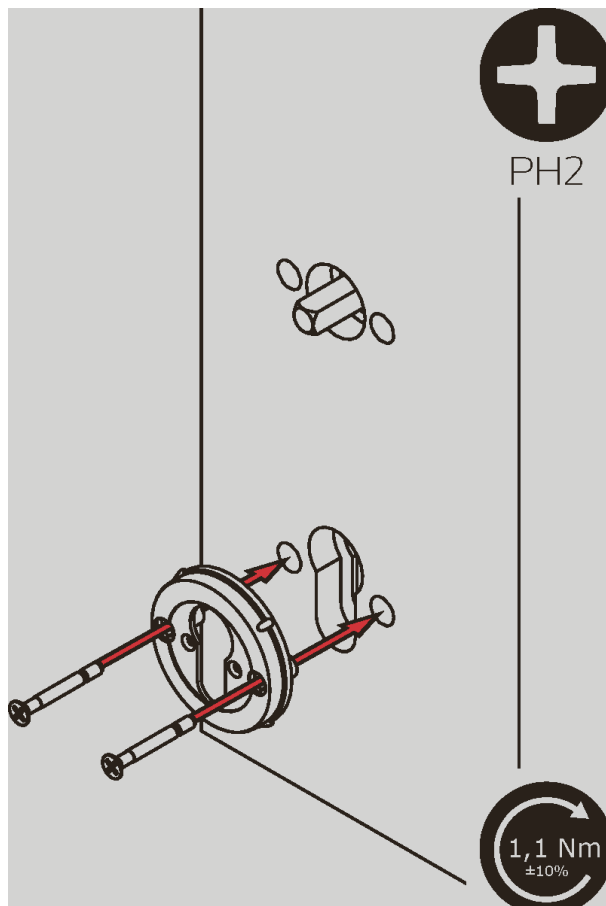

3. Insert the blind cylinder into the mortise lock.
4. Carefully place the adapter plate against the door.

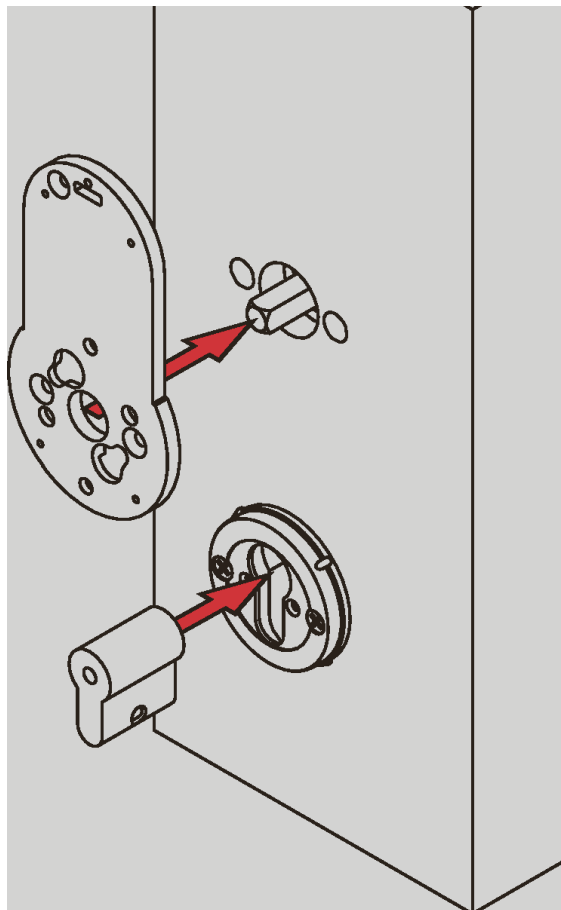

5. Align the adapter plate as shown (holes of the adapter plate horizontal and square in the middle).

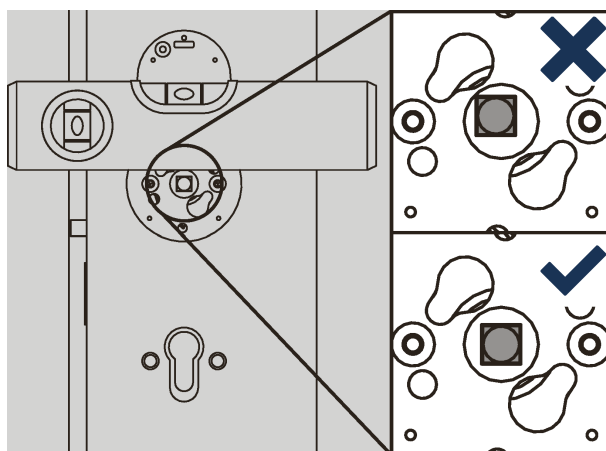

6. Screw the adapter plate and the dummy cylinder tight.

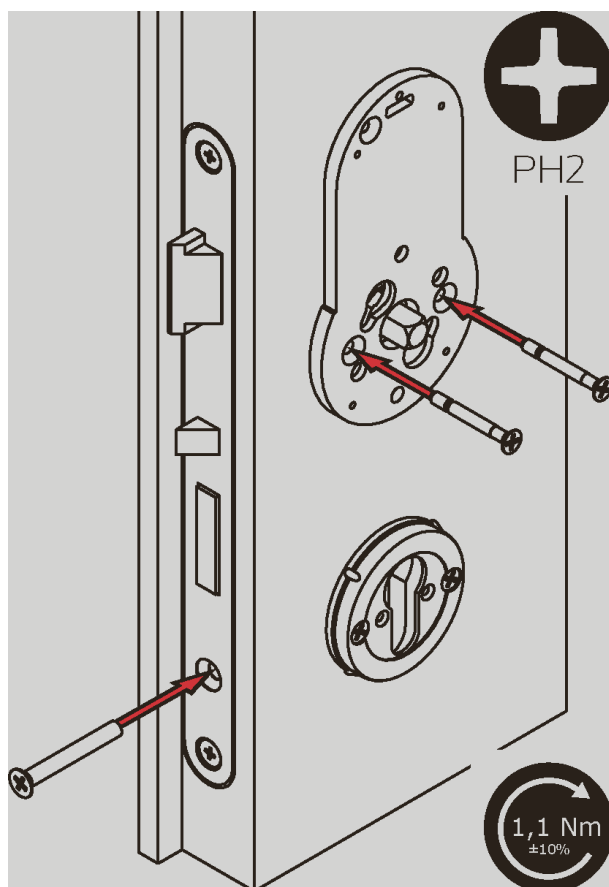

7. Wait five hours.

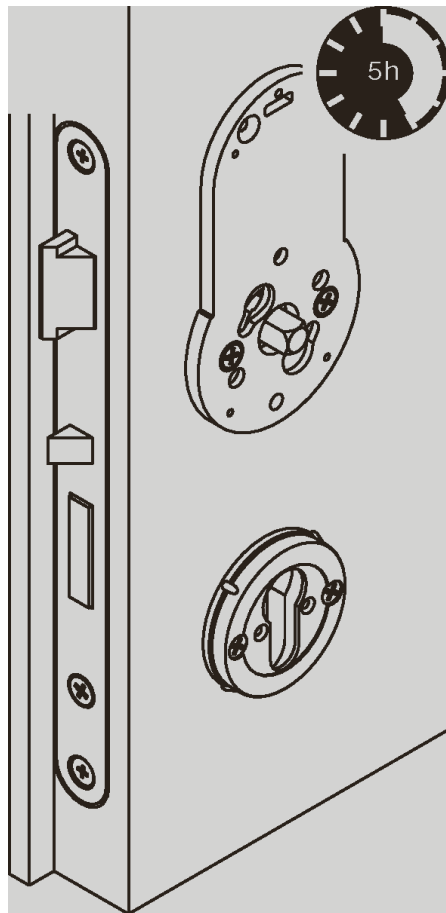

- ↳ Anti-slip film bonds to the door.
- ↳ External assembly mounted



NOTE

Skip waiting time

The non-slip film prevents the external assembly from twisting. If the handle on the inside is not pushed all the way until the anti-slip foil is tightened (five hours), you can finish assembly immediately.

Installing the inner assembly

1. Place the inner assembly diagonally on the openings of the adapter plate.

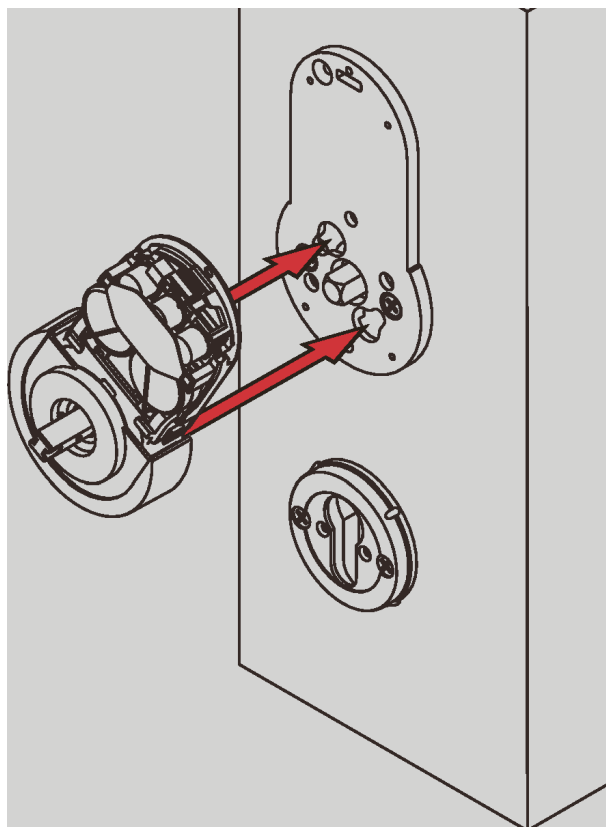

2. Turn the assembly counterclockwise until it is flush with the adapter plate.

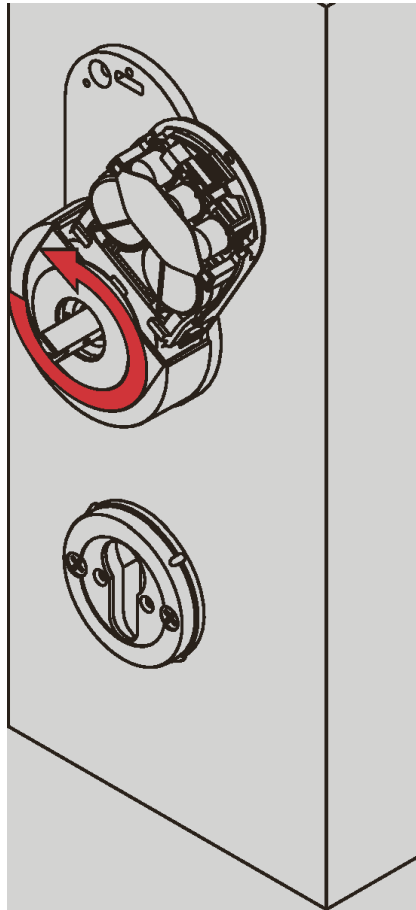

3. Fix the assembly to the adapter plate with the anti-rotation screw.
4. Push the cover onto the assembly.
↳ Both assemblies are mounted.

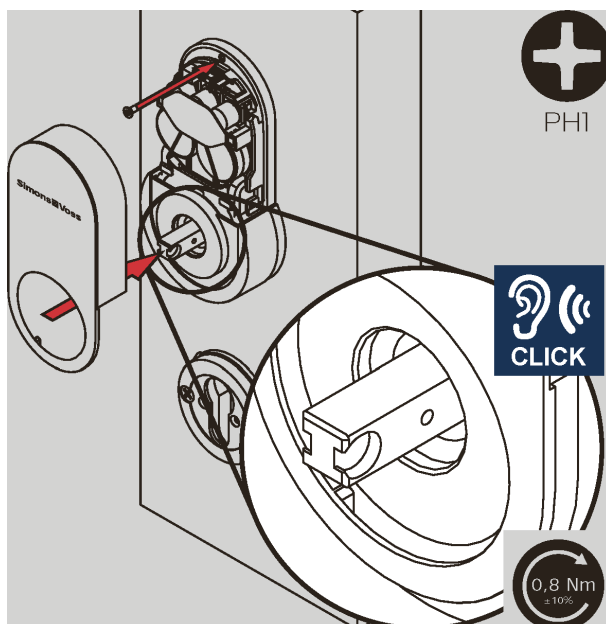

Mounting the handle

1. Fit the handles and the covers of the escutcheons.

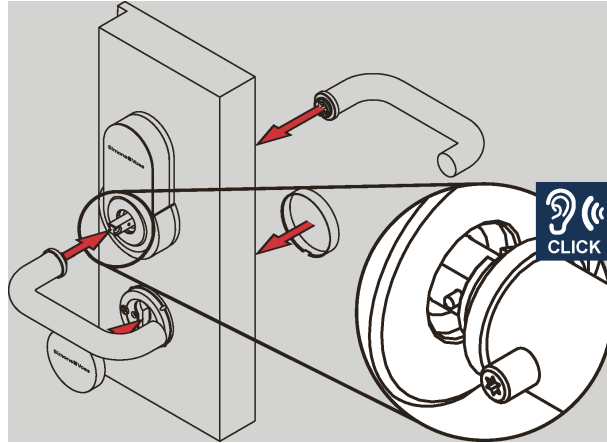

2. Screw on both handles.

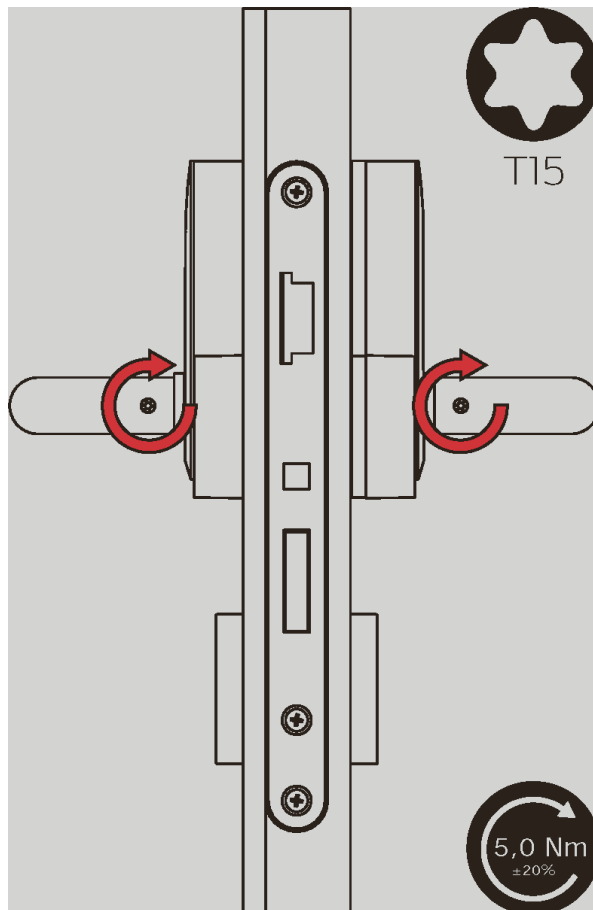

↳ SmartHandle AX are mounted.

7.7 Variants E0 and E1 (Scandinavian Oval)

The assembly of the variants E0 and E1 is very similar. Variant E1 differs from variant E0 by the break-out for the locking cylinder.

7.7.1 Contents of packaging

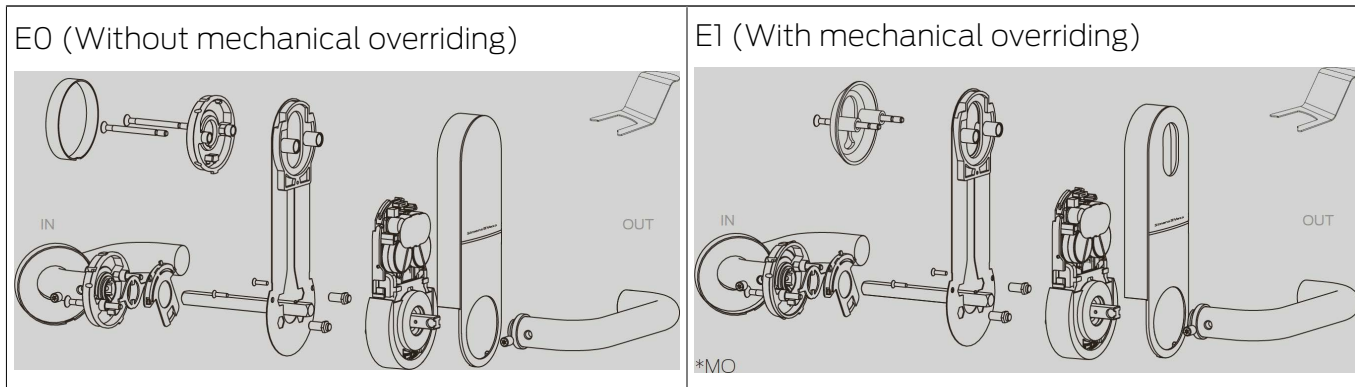

Quantity	Object	
1×	External fitting assembly, incl:	
	4×	Battery (CR2450)
	1×	Inlay
	1×	Support plate
	2×	PH2 screws
	1×	MO top group (not with MO)
	2×	Interchangeable bolts
1×	Exterior handle, incl:	
	1×	Headless screw
1×	Interior handle, incl:	
	1×	Headless screw
	1×	pre-assembled escutcheon base
1×	Exchangeable plate	
1×	Spring element	
1×	Escutcheon base for cylinder opening	
1×	Escutcheon cover for interior handle	
1×	Escutcheon diaphragm for cylinder opening (not for MO)	
2×	Screw with predetermined breaking points (long)	
2×	Screw with predetermined breaking points (short)	
1×	Spindle	
1×	Installation tool	
1×	Quick guide	

7.7.2 Tools

You require the following tools for installation:

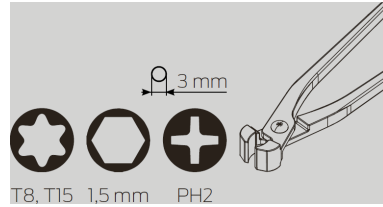

- TX-15 screwdriver
- TX-8 screwdriver
- PH2 screwdriver
- Suitable pliers for shortening screws, e.g. mechanic's nippers
- (X-variant: Saw for shortening square, e.g. hacksaw)

7.7.3 Procedure

Performing programming



NOTE

Duration of initial programming

A large amount of data is transferred during initial programming. The data transfer speed is significantly higher with a SmartStick AX or a SmartCD.MP (and the programming time is therefore shorter).

- If possible, use a SmartStick AX or a SmartCD.MP for initial programming.

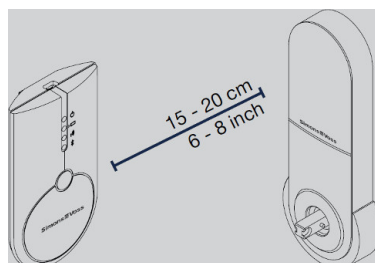

Fig. 7: Programming active (SmartCD.G2)

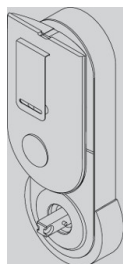

Fig. 8: Programming passive (SmartCD.MP)

- ✓ Locking device added in LSM software.
 - ✓ LSM software launched.
 - ✓ Programming device connected.
1. Position the programming device.
 2. Programme the SmartHandle AX (see , quick guide or LSM manual for details).
- ↳ SmartHandle AX is programmed.

Shorten screws

Screw/square	Length
2× L1	T + 10 mm (± 3 mm)
2× L2	T + 3 mm (± 3 mm)
Spindle	T + 37 mm (± 4 mm)

1. Measure the thickness of the door (T).

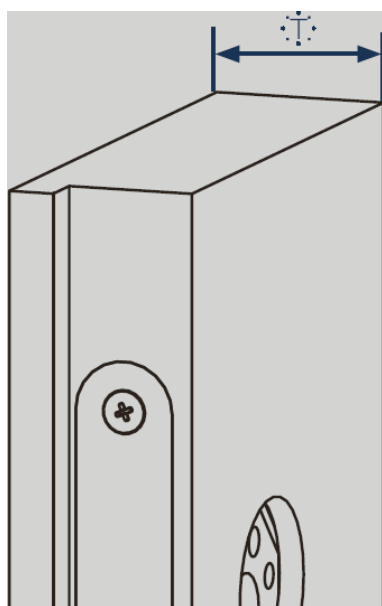

2. Calculate the screw lengths.
3. Select suitable predetermined breaking points that are no more than 3 mm from the calculated length.

4. Separate the predetermined breaking points with pliers.

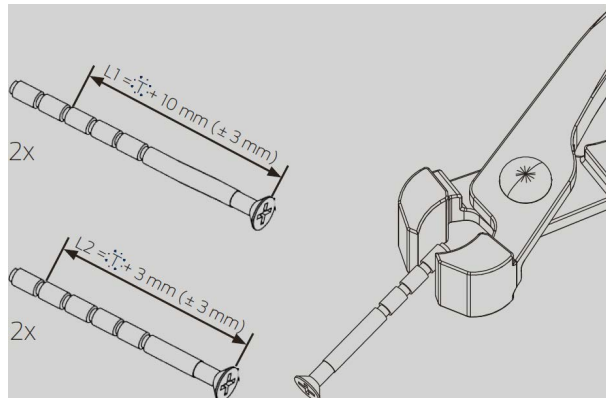

↳ Screws shortened.

X-variant

If you have ordered version X for very thick doors, your delivery includes an extra long square rod and threaded rods together with extension sleeves. In this case the length specification refers to the total length of the screw (= screw, extension sleeve and threaded rod).

▣ Proceed as described below.

1. Assemble the screws, the extension sleeves and the threaded rods.

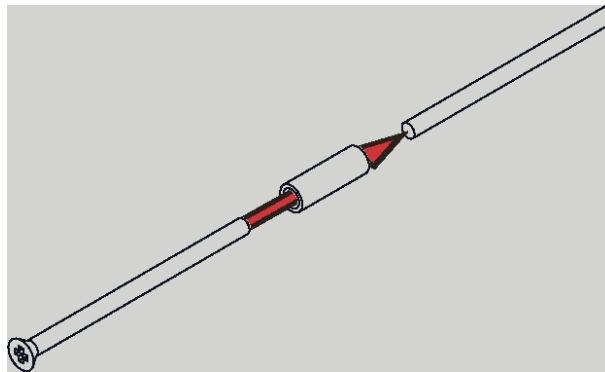

2. Shorten the screws and the square.

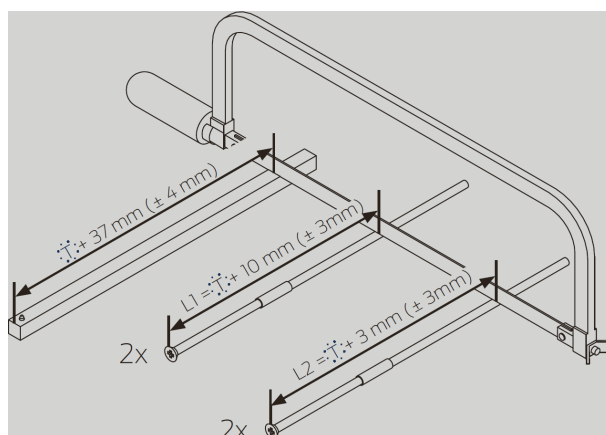

↳ Screws and square of the X-variant are shortened.

Identify door direction

The preparation of the interior handle varies depending on the opening side of the door (DIN R or DIN L).

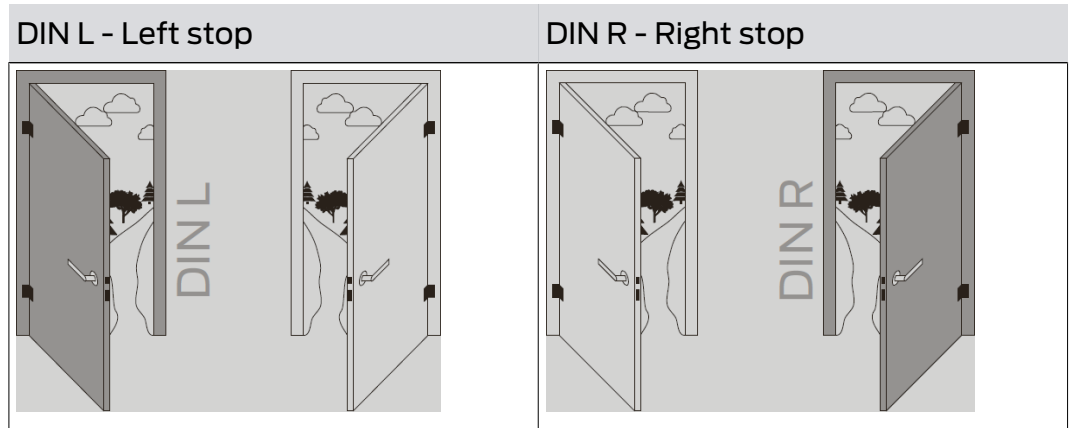

Prepare the interior handle (DIN R)

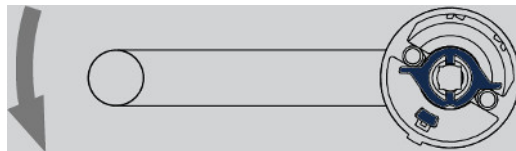

1. Insert the switching plate as shown.

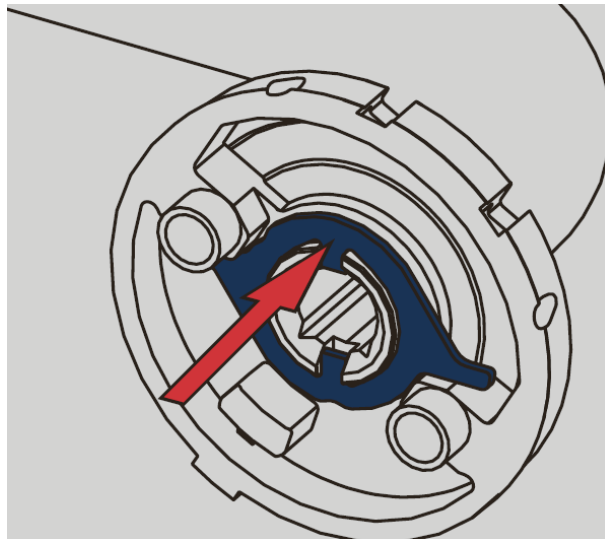

2. Position the spring sub-assembly at an angle to the escutcheon base until it touches the switching plate.

3. Draw the spring sub-assembly back, so that the spring is compressed.

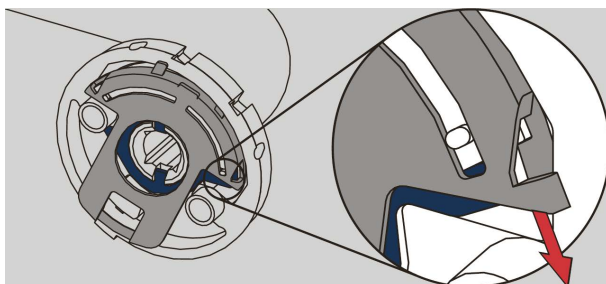

4. Slide the spring sub-assembly pawls into the escutcheon base.

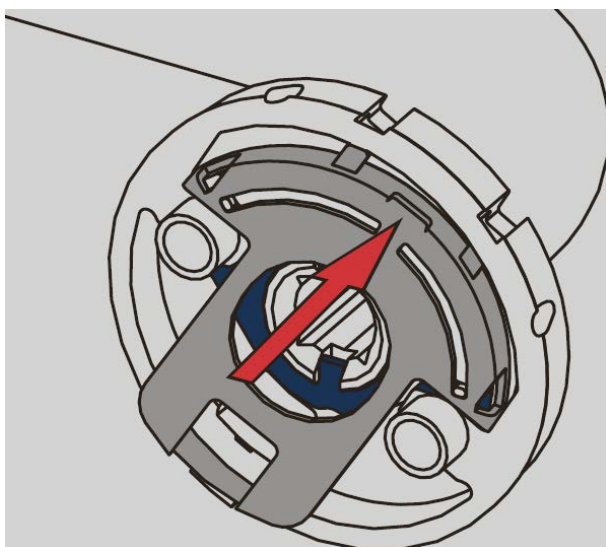

5. Press the rear clip into the designated pawl.

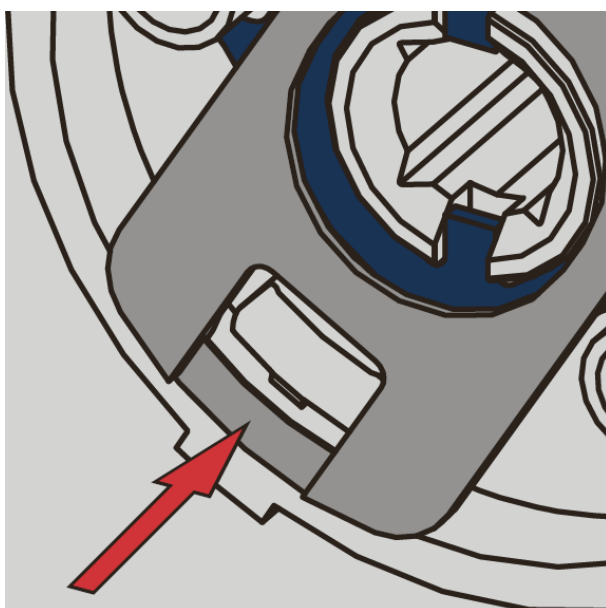

↳ Spring plate is inserted.

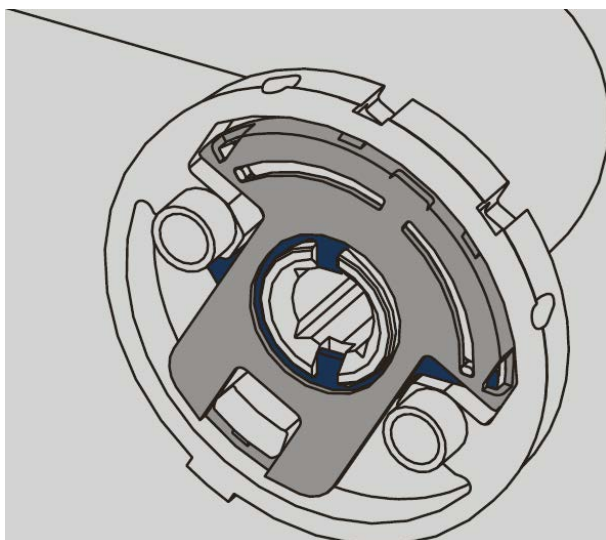

Prepare the interior handle (DIN L)



1. Insert the switching plate as shown.

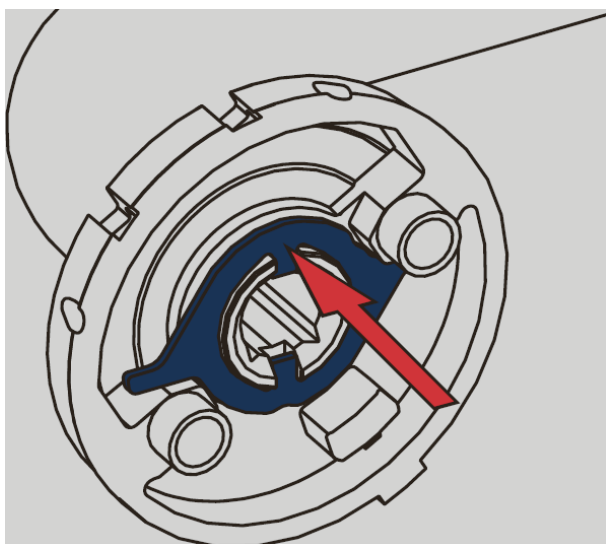

2. Position the spring sub-assembly at an angle to the escutcheon base until it touches the switching plate.

3. Draw the spring sub-assembly back, so that the spring is compressed.

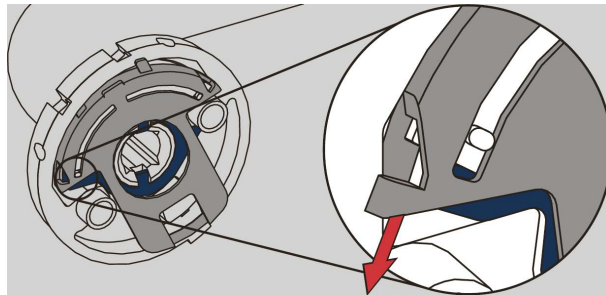

4. Slide the spring sub-assembly pawls into the escutcheon base.

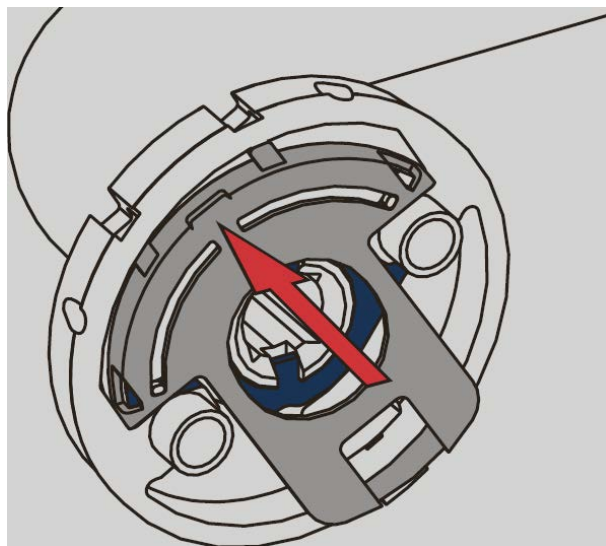

5. Press the rear clip into the designated pawl.

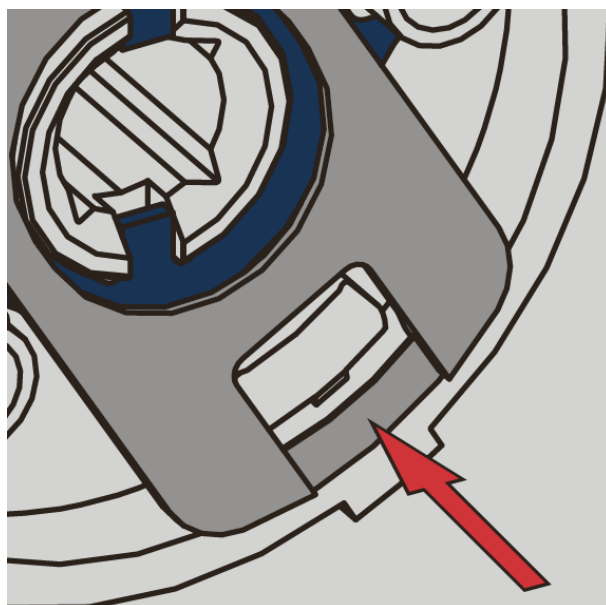

↳ Spring plate is inserted.

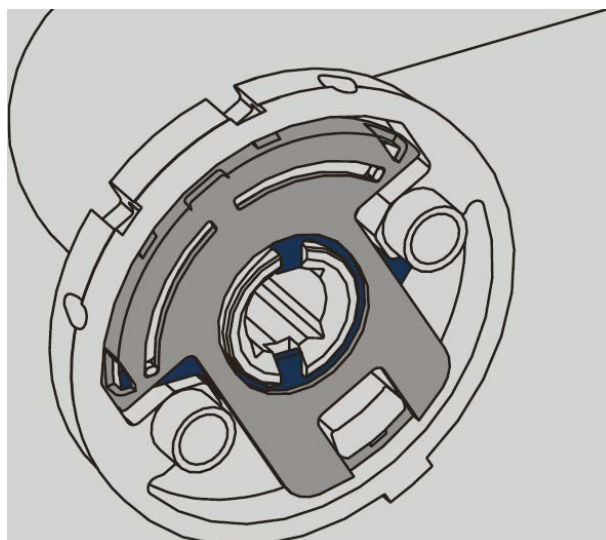

Turn stud bolt (only for DIN R)

Your SmartHandle AX is supplied ex works in the Scandinavian Oval version with matching stud bolts for DIN L doors. If you want to use your SmartHandle AX on a DIN R door, then screw the stud bolts around as follows:

1. Unscrew only the screws shown.

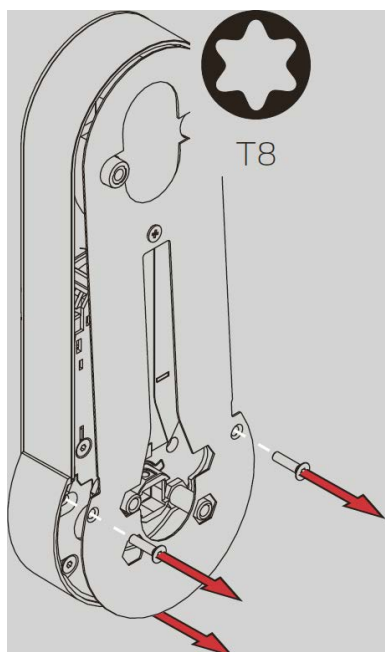

2. Remove the cover plate.

3. Unscrew the stud bolts.

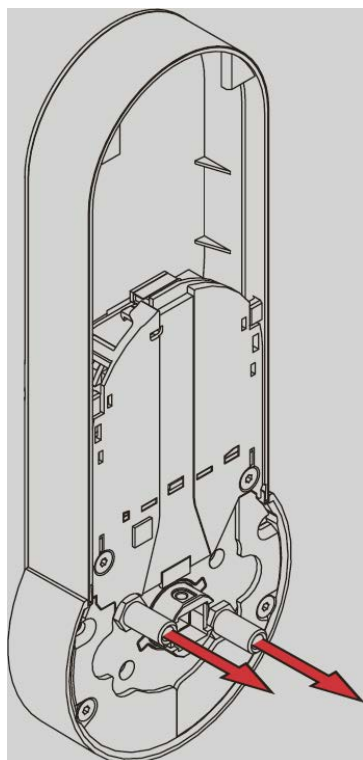

4. Screw in the stud bolts as shown.

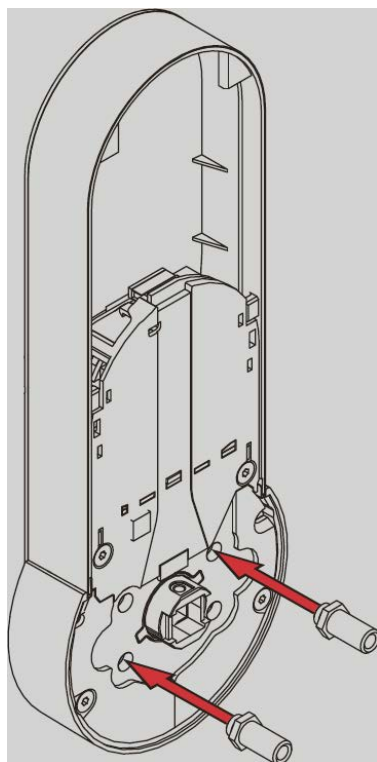

5. Put the cover plate back in place.

**NOTE****Recesses congruent with stud bolts**

The cover plate has recesses which later prevent the stud bolts from loosening.

1. Make sure that the recesses enclose the hexagon of the stud bolts.
2. If necessary, turn the stud bolts until the hexagon fits into the recesses provided.

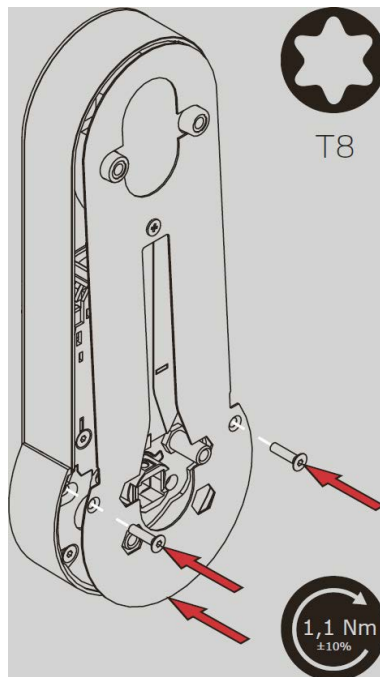

6. Screw the screws shown back in (T8, torque: 1.1 Nm).

↳ Assembly is prepared for DIN R.

Insert square**NOTE**

If you use a 7 mm spindle, attach the adapter shoe to the spindle before fitting the spindle.

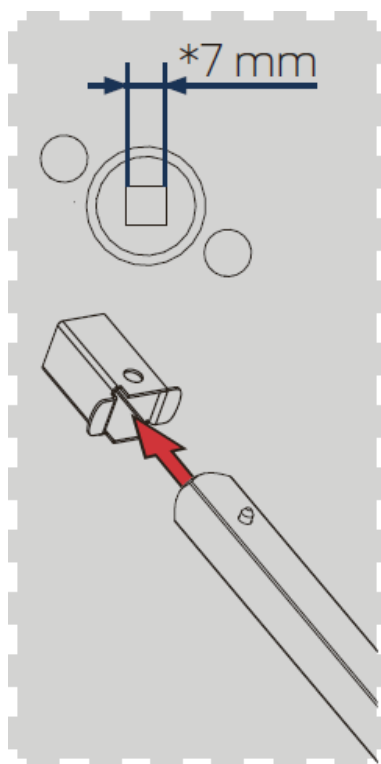

- Slide the square into the square socket of your SmartHandle AX until the pin of the square engages.

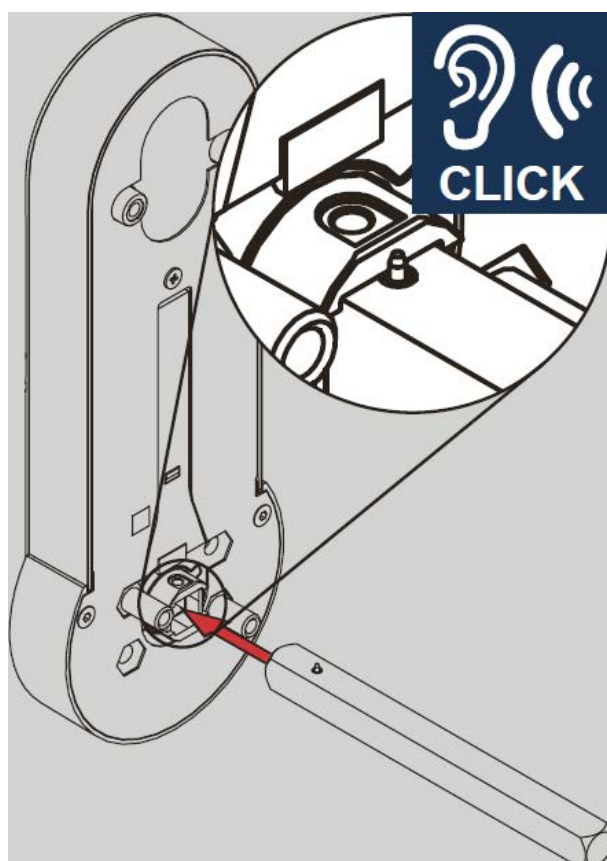

- ↳ Square is inserted.

Mount the assembly

1. Push the sub-assembly with the spindle into the door from the outer side.

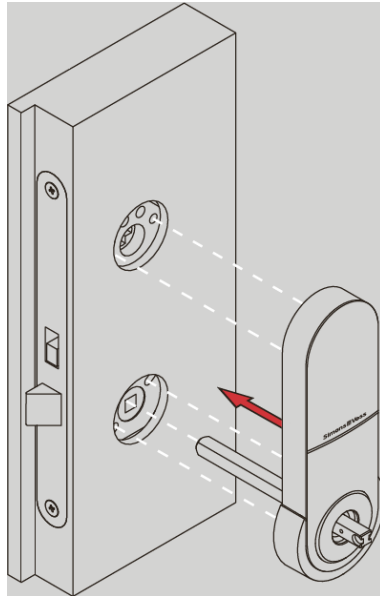

2. Position the escutcheon base for the cylinder opening on the other side of the door.
3. Screw the escutcheon base tight with the L1 screws (MO: Screw the complete escutcheon with the L1 screws)(PH2, torque: 1.1 Nm).



NOTE

If you use a 7 mm spindle, place the adapter sleeve on the free side of the spindle.

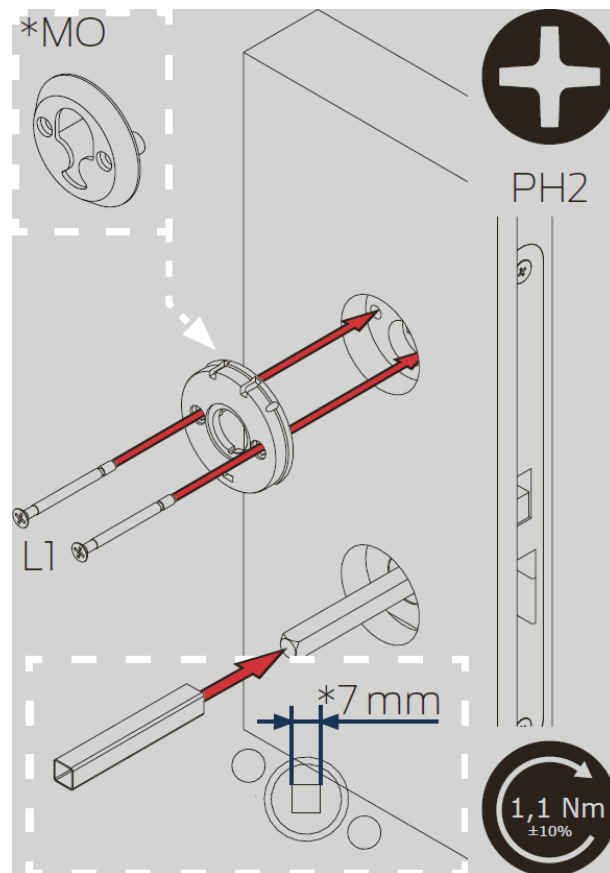

4. Screw the handle to the assembly with the L2 screws (PH2, torque: variable mounted. 1.1 Nm).

**NOTE**

Press the handle downwards if there is not enough room.

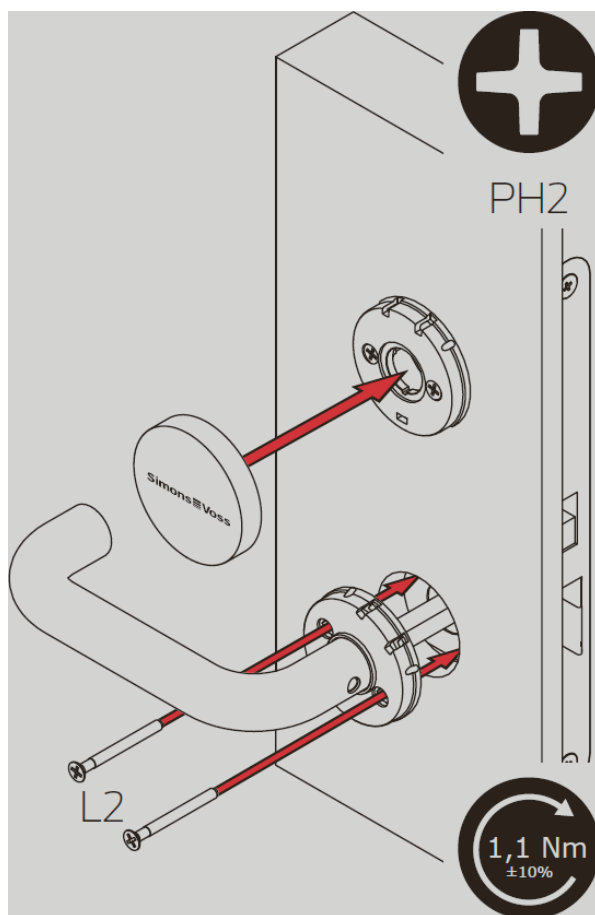

5. Press the escutcheon onto the escutcheon base on the cylinder opening until it locks into place.

6. Screw the headless screw into the handle to fix it in place (T15, torque: 5.0 Nm)

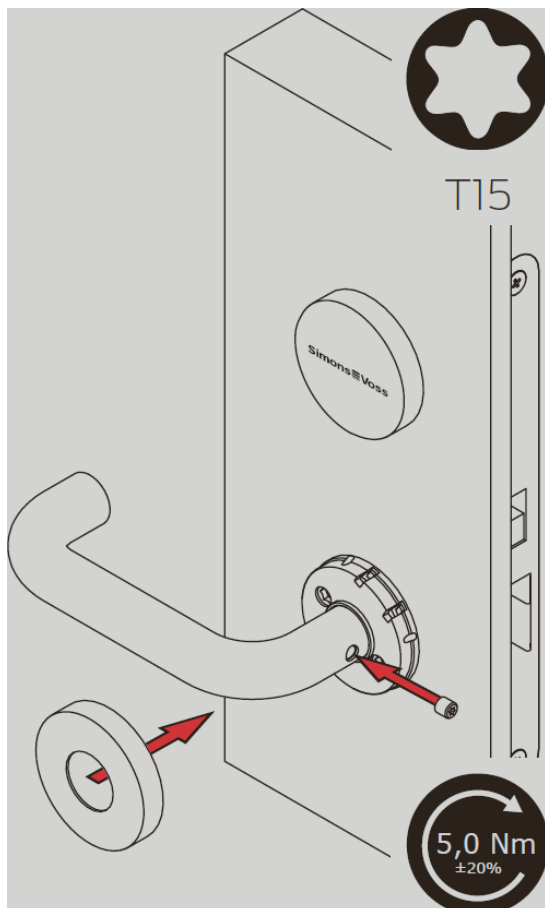

7. Slide the escutcheon along the handle and press the escutcheon onto the escutcheon base until it locks into position.
↳ The sub-assembly is mounted.

Fit exterior handle

1. Push the outer handle into the sub-assembly until the pin locks into the spindle.

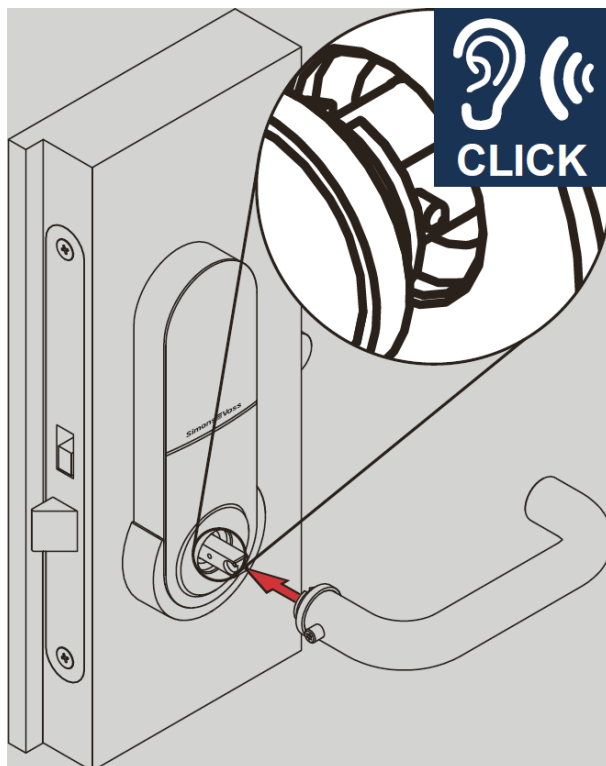

2. Screw the headless screw into the handle to fix it in place (T15, torque: 5.0 Nm)

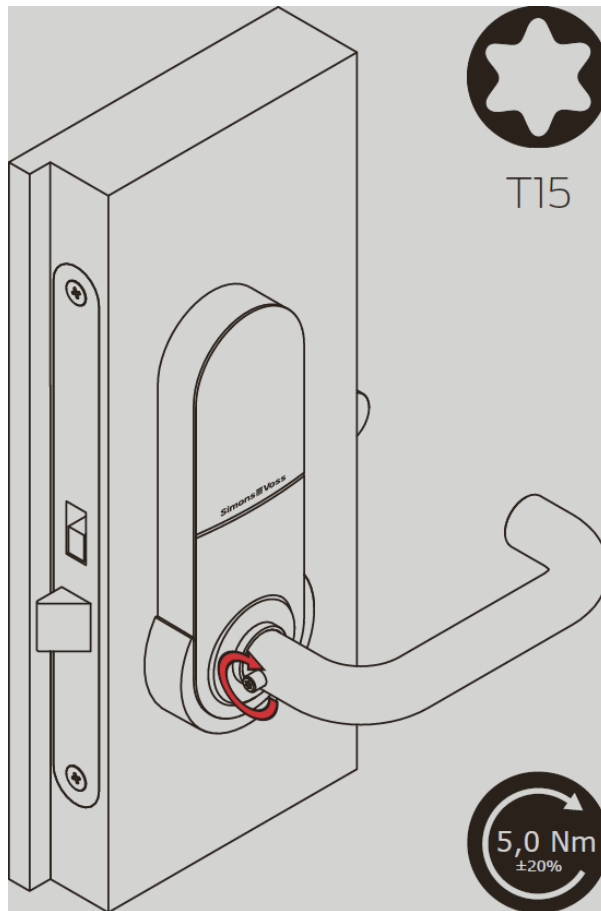

↳ SmartHandle AX mounted.

7.8 LockNode (LNI)

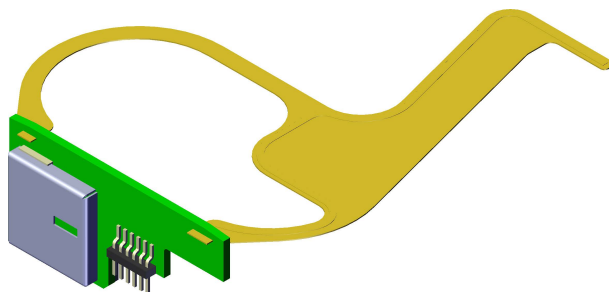

7.8.1 Contents of packaging

The package contains the LockNode and the quick guide.

7.8.2 Tools

You do not need any tools other than the SimonsVoss installation tool. The installation tool is included in the scope of delivery of your SmartHandle AX.

7.8.3 Procedure

IMPORTANT**Damage to the flex board**

The flex board is sensitive to mechanical stress.

- ❑ Do not bend the flex board.

1. Insert the mounting tool into the opening slots provided for this purpose.

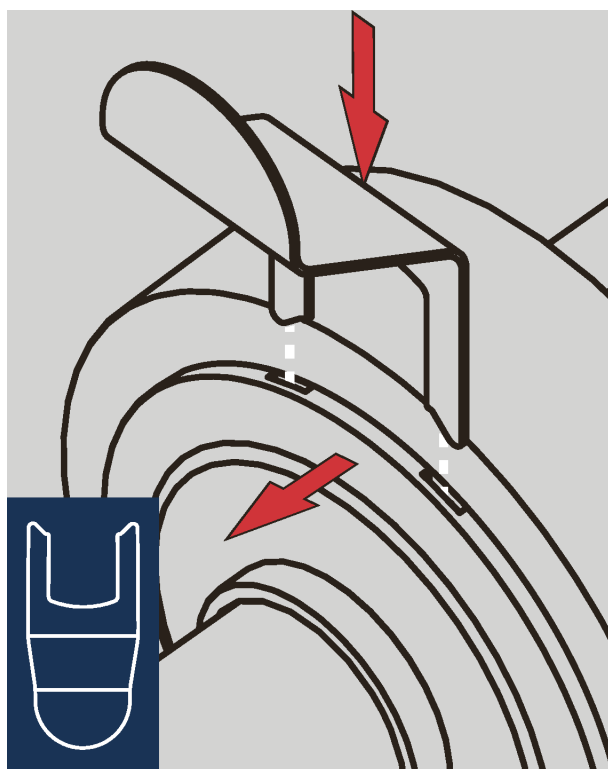

- ↳ Cover loose.

2. Pull the cover downwards (or upwards)

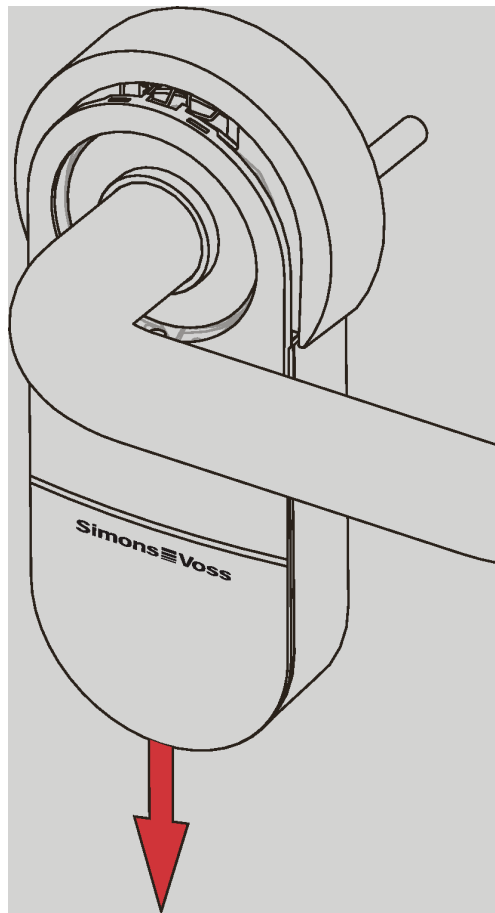

3. Take off the cover.

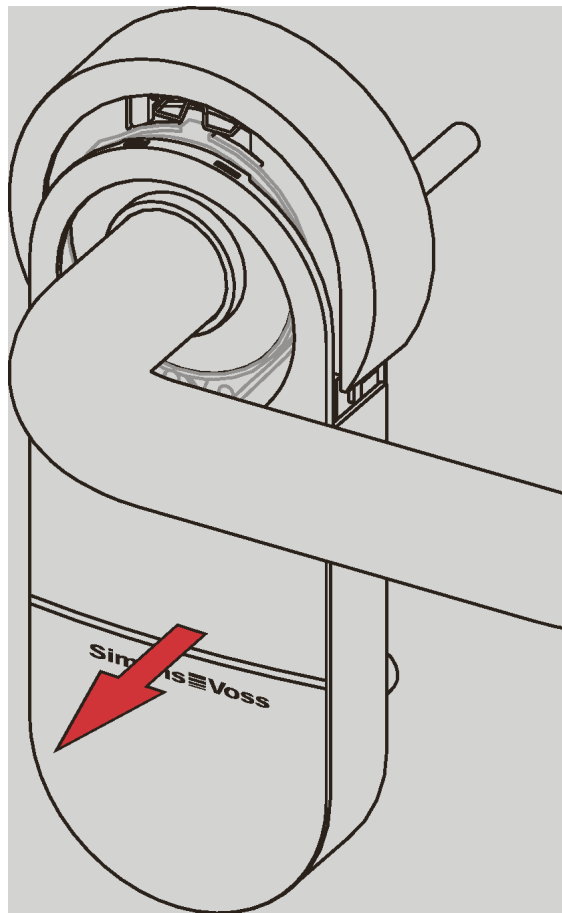

4. Insert the pins of the LockNode into the designated slot on the board of the SmartHandle AX.

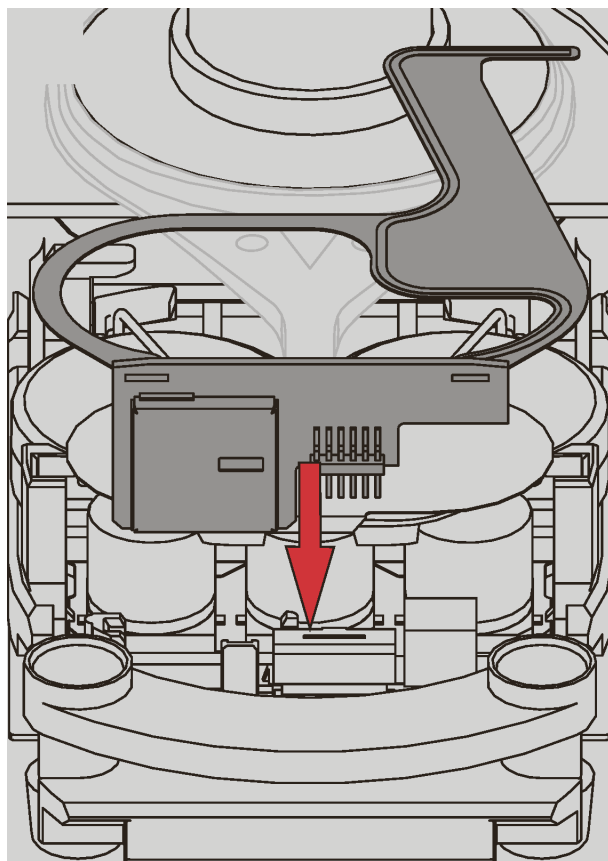

5. Press the LockNode firmly until the plastic latch snaps into the metal holder of the LockNode.

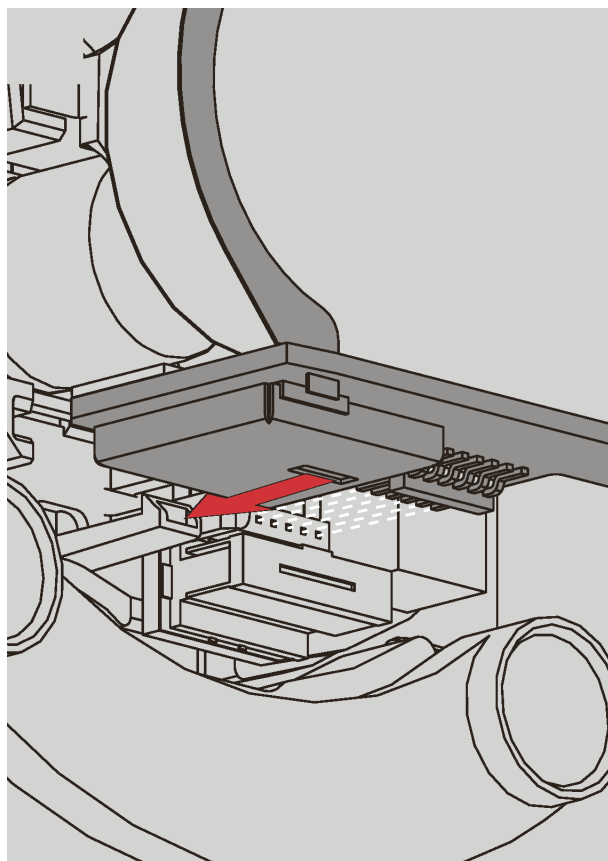

↳ SmartHandle AX beeps and flashes four times.

6. Slide the end of the flex board under the transparent plastic ring of the SmartHandle AX.



7. Press the end of the flex board under the holder provided.

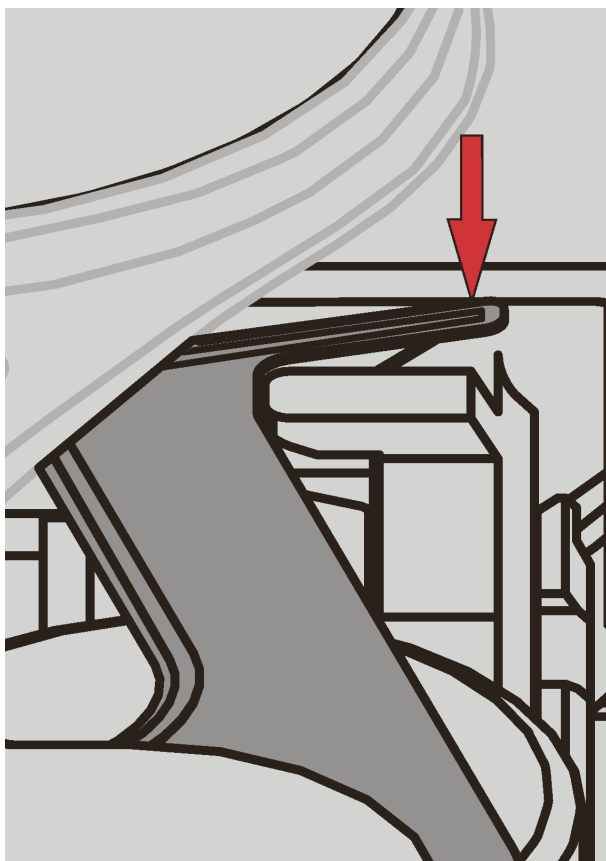

8. Carefully put the cover back on.

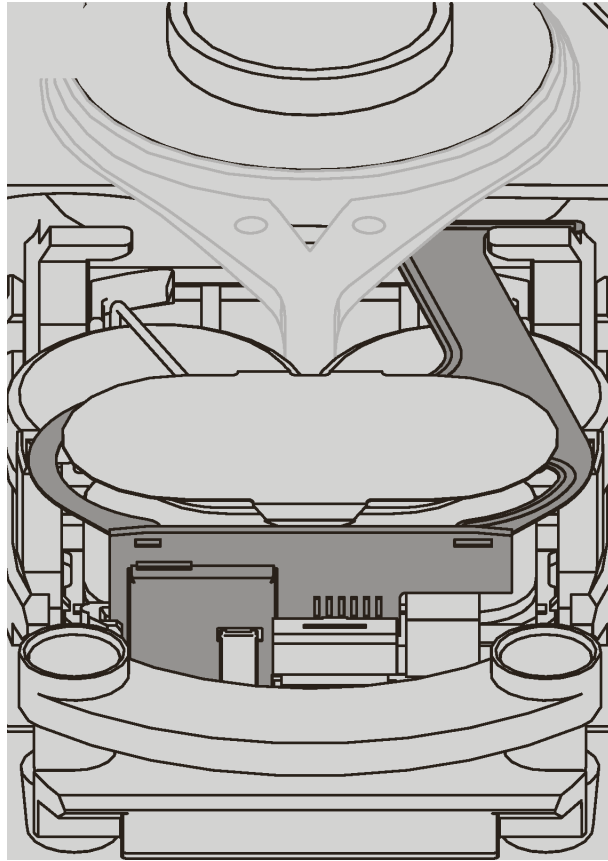

↳ LockNode is mounted.

8 Programming

- ✓ LSM software version 3.4 SP1 or higher installed.
 - ✓ LSM open.
 - ✓ SmartCD.MP or SmartCD.G2 connected (recommended: SmartCD.MP).
1. Select the locking system that you require. Use the **...** button to open the locking system properties and use the **▶** and **◀** buttons to select the required lock system.
 2. Click on the **+** button to add a new locking device.
 - ↳ The "New lock" window will open.
 3. Open the **▼ Area** drop-down menu.
 4. Select the area.
 5. Open the **▼ Lock type** drop-down menu.
 6. Select the "AX SmartHandle" item.
 7. Complete the rest of the form.
 8. Click on the **Save & next** button.
 - ↳ Locking device has been added.
 9. Click on the **Exit** button.
 - ↳ Window closes.
 10. Highlight the entry on the SmartHandle AX in the matrix.
 11. Align the Smart CD.MP with the SmartHandle AX or place the SmartCD.G2 about ten centimetres away from the SmartHandle.AX.



NOTE

Duration of initial programming

A large amount of data is transferred during initial programming. The data transfer speed is significantly higher with a SmartStick AX or a SmartCD.MP (and the programming time is therefore shorter).

- If possible, use a SmartStick AX or a SmartCD.MP for initial programming.

12. Right-click on the SmartHandle AX entry in the matrix to open the context menu.
13. Select the **Programming** item.
14. Open the **▼ Type** drop-down menu.
15. Select the "Card reader (SmartCD MP)" entry or "SmartCD" entry.
16. Click on the **Programming** button.
 - ↳ Programming launches.
17. Wait for programming to complete.
 - ↳ SmartHandle AX is programmed.

9 Configuration

9.1 Pulse length

SmartHandle is pre-set to engage for about 5 seconds. The time that it engages can be freely configured between 1 and 25 seconds for each lock in the software. This does not result in a shorter battery life.

9.2 Access control

Identification media bookings are logged if access control is activated. The following information is stored in SmartHandle.

- Date
- Time
- Identification medium ID

Each SmartHandle AX can store up to 3,000 bookings.



NOTE

These settings are only available in the .ZK version.

- ✓ LSM open.
- 1. Double-click on the SmartHandle AX entry in the matrix to open the settings.
- 2. Change to the [Configuration/Data] tab.
- 3. Enable the Audit trail checkbox.
- 4. Click on the **Apply** button.
- 5. Click on the **Exit** button.
- ↳ Access control is enabled.

Only authorised transponder operations are logged by default. However, you can also log non-authorised bookings (see *Logging unauthorised attempted access events* [▶ 156]). You will find information on how to read access lists in the LSM manual.

9.3 Time zone control

You can load a time zone plan. Identification media will then be granted or denied access based on their time zone group. Up to 100+1 time groups are possible.

You can also implement automatic time-controlled changeover using a time zone plan (see *Time switch-over function* [▶ 157]).

**NOTE**

These settings are only available in the .ZK version.

- ✓ LSM open.
 - ✓ Add time zone plan (see LSM manual).
1. Double-click on the SmartHandle AX entry in the matrix to open the settings.
 2. Change to the [Door] tab.
 3. Open the ▼ **Time zone** drop-down menu.
 4. Select your time zone.
 5. Click on the **Apply** button.
 6. Click on the **Exit** button.
- ↳ Time zone is selected.

9.4 Logging unauthorised attempted access events

Only authorised accesses are logged in storage mode. There is an option to log unauthorised access attempts too.

**NOTE**

These settings are only available in the .ZK version.

- ✓ LSM open.
1. Double-click on the SmartHandle AX entry in the matrix to open the settings.
 2. Change to the [Configuration/Data] tab.
 3. Enable the Log unauthorised attempts checkbox.
 4. Click on the **Apply** button.
 5. Click on the **Exit** button.
 6. Execute programming (see).
- ↳ Unauthorised access attempts are now also logged.

9.5 Flip flop

Pulse mode (default setting) is switched off and the pulse duration is no longer in effect. When flip flop mode is activated, the SmartHandle changes its status from engaged to disengaged or vice versa each time it is

activated using a transponder/SmartCard. This mode is suitable for situations such as when a door needs to be used freely without a transponder/SmartCard to allow visitors to enter, for instance

9.6 Close range mode

A reduced reader range is required in some situations. The near-field mode reduces the reader range for transponders. This diminishes the impact of possible interferences and prevents the transponder from overriding.

- ✓ LSM open.
- 1. Double-click on the SmartHandle AX entry in the matrix to open the settings.
- 2. Change to the [Configuration/Data] tab.
- 3. Enable the Close-up range mode checkbox.
- 4. Click on the **Apply** button.
- 5. Click on the **Exit** button.
- 6. Execute programming (see).
- ↳ Near-field mode is activated.

9.7 Time switch-over function

The fifth group in the time zone plan is relevant for time change-over.



NOTE

These settings are only available in the .ZK version.

Assignment of a time zone plan

- ✓ LSM open.
- ✓ Add time zone plan (see LSM manual).
- 1. Double-click on the SmartHandle AX entry in the matrix to open the settings.
- 2. Change to the [Door] tab.
- 3. Open the ▼ **Time zone** drop-down menu.
- 4. Select your time zone.
- 5. Click on the **Apply** button.
- 6. Click on the **Exit** button.
 - ↳ Time zone is selected.

Activating time zone control and time change-over

Whereas time zone control itself can only influence identification media authorisations, the time change-over also activates time-dependent switching of the relay in the controller. Both need to be enabled.

- ✓ LSM open.
 - ✓ Time zone plan assigned.
1. Double-click on the SmartHandle AX entry in the matrix to open the settings.
 2. Change to the [Configuration/Data] tab.
 3. Enable the Time zone management checkbox.
 4. Enable the Time switching checkbox.
 5. Click on the **Extended configuration** button.
 - ↳ The "Extended configuration" window will open.

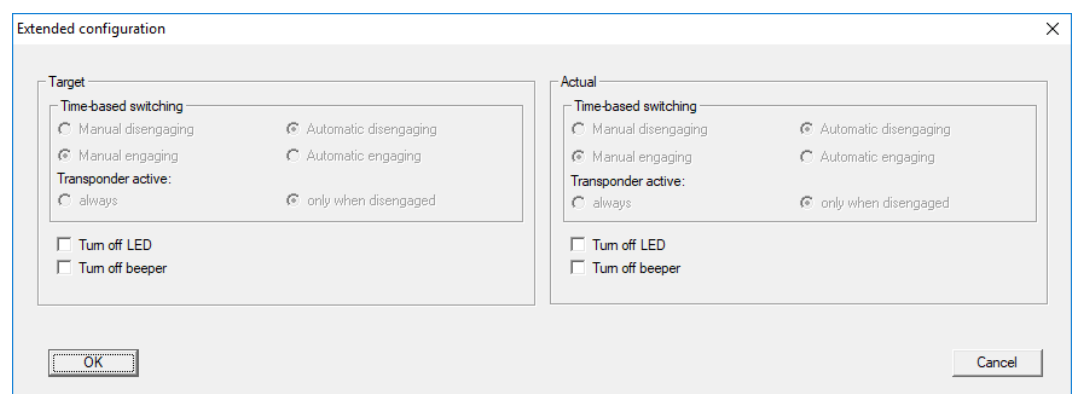

6. Set the options for automatic and manual locking and unlocking in the "Time-based switching" section as you require (see *Time-controlled changeover* [[▶ 159](#)]).
7. Click on the **OK** button.
 - ↳ Window closes.
8. Click on the **Apply** button.
9. Click on the **Exit** button.
 - ↳ Time zone control and time change-over are activated.

Editing the time zone plan

See LSM manual to edit the time zone plan.

9.8 Ignore activation or expiry date

Identification media can be given a validity date. This validity date can be ignored if identification media need to be used regardless.

- ✓ LSM open.
- 1. Double-click on the SmartHandle AX entry in the matrix to open the settings.
- 2. Change to the [Configuration/Data] tab.
- 3. Enable the Ignore activation or expiry date checkbox.
- 4. Click on the **Apply** button.
- 5. Click on the **OK** button.
- 6. Execute programming (see).
- ↳ Activation or expiry date is ignored.

9.9 No audible programming feedback signals

You should check this field if you do not want audible programming feedback signals to be emitted while you are programming a SmartHandle, for example.

This function is particularly advantageous when programming via the WaveNet (network) as the audible signal from SmartHandle cannot be heard as a general rule due to distance.

9.10 Card interface

You need to activate the Card interface box in the locking device properties when using a SmartHandle Hybrid or MP.

9.11 Extended configuration

9.11.1 Time-controlled changeover



NOTE

These settings are only available in the .ZK version.

Unlock in the authorised time period			
Engage automatically		Engage manually	
always	only when disengaged	always	only when disengaged

Unlock in the authorised time period			
SmartHandle AX: engages to open as soon as authorisation starts in the time zone plan. Behaves in the same way as a flip-flop for the remaining authorised time period.	SmartHandle AX: engages to open as soon as authorisation starts in the time zone plan. No influence by identification media for the rest of the authorised time period.	SmartHandle AX: engages to open as soon as identification medium is activated after authorisation starts in the time zone plan. Behaves in the same way as a flip-flop for the remaining authorised time period.	SmartHandle AX: engages to open as soon as identification medium is activated after authorisation starts in the time zone plan. No influence by identification media for the rest of the authorised time period.
Locking in the non-authorised time period			
Disengage automatically		Disengage manually	
always	only when disengaged	always	only when disengaged
SmartHandle AX: disengages as soon as authorisation ends in the time zone plan. Identification media engage ready to open during non-authorised time period for pre-set pulse duration.	SmartHandle AX: disengages as soon as authorisation ends in the time zone plan. Identification media engage ready to open during non-authorised time period for pre-set pulse duration.	SmartHandle AX: disengages as soon as the identification medium is activated. Identification media engage ready to open during non-authorised time period for pre-set pulse duration.	Not possible

9.11.2 Turn off LED/beeper

You can also adjust signal settings as you wish.

Open extended configuration

✓ LSM open.

1. Double-click on the SmartHandle AX entry in the matrix to open the settings.
2. Change to the [Configuration/Data] tab.

3. Click on the **Extended configuration** button.
↳ The "Extended configuration" window will open.

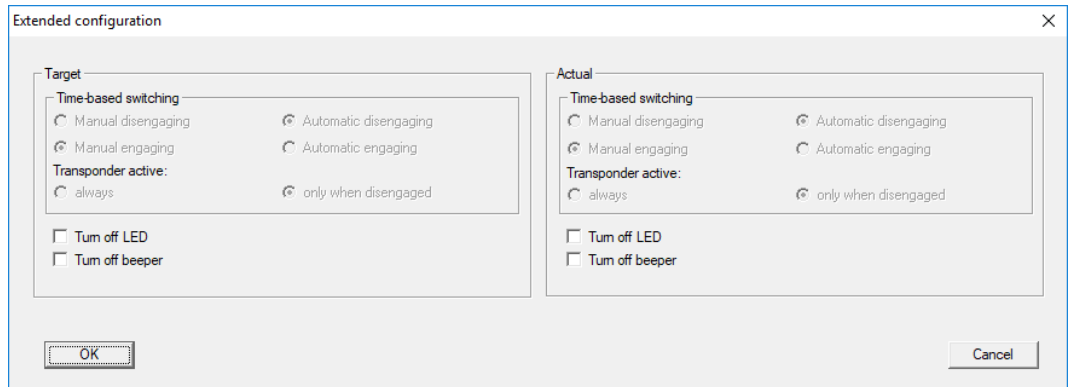

Turn off LED/beeper

- ✓ LSM open.
 - ✓ "Extended configuration" window open.
1. Enable the Turn off LED checkbox or the Turn off beeper checkbox.
 2. Click on the **OK** button.
↳ Window closes.
 3. Click on the **Apply** button.
 4. Click on the **Exit** button.
 5. Execute programming (see).
↳ LED or beeper is switched off.

10 Operation

The SmartHandle AX can be operated in different ways, depending on the programming.



NOTE

Gap

The size of the gap affects the wireless connection.

1. If you use a transponder, you must position it between five and thirty centimetres away.
2. If you use a passive medium, place it under the groove on the cover. If there is no groove, position the identification medium on the SimonsVoss inscription.

Pulse opening

To use pulse opening, ensure that the Flip Flop checkbox is disabled.

✓ Identification medium is authorised to use the SmartHandle AX.

1. Position the identification medium.
 2. If you are using a transponder, press it once.
 - ↳ SmartHandle AX will beep and flash green twice.
- ↳ The SmartHandle AX will remain open for the pre-set pulse interval.

Flip-flop mode

To use flip-flop mode, ensure that the Flip Flop checkbox is enabled.

✓ Identification medium is authorised to use the SmartHandle AX.

1. Position the identification medium.
 2. If you are using a transponder, press it once.
 - ↳ When the SmartHandle AX engages to open, it will beep and flash (short-long).
 - ↳ When SmartHandle AX is decoupled, it will beep and flash (long-short).
- ↳ The SmartHandle AX will remain engaged to open or decoupled until it is activated again.

11 Status messages

11.1 Battery status feedback

OK	Batteries OK. You do not need to do anything.
Low	Batteries low. Change the batteries.
Very low	Batteries very low. Replace the batteries immediately.

11.2 Emergency release

11.3 Deactivated

If SmartHandle is deactivated via a SimonsVoss Block Lock or the SV network, the programming software automatically checks this box.

11.4 Engaged

This box is checked when SmartHandle is engaged for use if a time switch-over or flip-flop mode is programmed.

11.5 Possible DoorMonitoring states of SmartHandle AX

- Door open/closed (prepared, retrofittable)
- Door open for too long (prepared, retrofittable)
- Locked (only for self-locking mortise locks, retrofittable)
- Handle in use/not in use
- Sabotage detection

12 Signal

Signal	Meaning
2x short before engaging to open (green)	Identification medium accepted – normal activation
1 x short (red)	Identification medium not authorised
1× short, 1× long (green)	Flip-flop mode: Locking device is now engaged ready to open
1× long, 1× short (green)	Flip-flop mode: Locking device is now disengaged

13 Battery warning

You or the user will be warned of a failure of the SmartHandle AX by flat batteries. Replace the batteries in time (see *Battery replacement* [▶ 166]). The electronic part with the batteries is located on the outside. If the batteries are completely empty, you can still reach the SmartHandle AX to change the batteries.

13.1 Warning level

warning level	Signalling	Meaning
Warning Level 1	8 x short bleep/flash before engagement (red)	Batteries are nearly dead and must be changed. Remaining openings (temperature dependent): min. 10000 or 6 months
Warning Level 2	16 x short bleep/flash before engagement (red)	Batteries are very weak and must be changed immediately. Remaining openings (temperature dependent): min. 1000 or 2 months

14 Battery replacement

14.1 Instructions on battery replacement

- ❑ Only specialists may replace the batteries.
- ❑ Do not touch electronics/components; do not allow them to come into contact with oil, paint, moisture, alkali or acids.
- ❑ Only use batteries approved by SimonsVoss.
- ❑ The batteries used may pose a fire or burn hazard if handled incorrectly. Do not recharge, open, heat or burn these batteries. Do not short-circuit!
- ❑ Dispose of old or used batteries correctly. Store out of children's reach.
- ❑ Check the polarity of the batteries.
- ❑ The batteries will have discharged to roughly the same level. That is why you must replace all batteries.
- ❑ Do not touch the contacts on the new batteries with your hands when replacing the old ones. Use cotton gloves free of fat or grease.
- ❑ When replacing the batteries, make sure that no pressure is applied to the electronics or that they are not damaged in any other way.

14.2 Procedure

The batteries are located under the cover of the SmartHandle AX. You will need the SimonsVoss installation tool to change the batteries.

1. Place the SimonsVoss installation tool in the recesses provided in the cover. These are located on the side facing away from the electronics.



2. Push the SimonsVoss mounting tool into the recesses until the cover pops out.
3. Pull the cover downwards until it clicks loose.
4. Remove the cover.

5. Press the end of the battery clip inwards until it pops out.

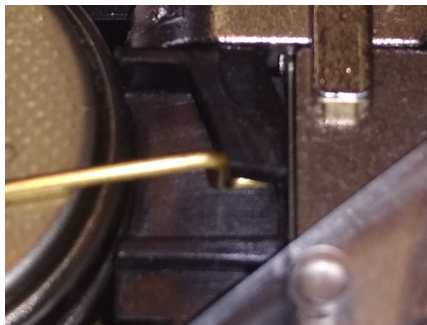
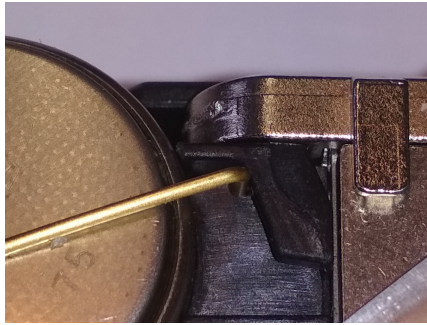

IMPORTANT

Loss of the battery clip

The battery clip is plugged in. If both ends of the clip are pushed inwards and released from the holder at the same time, the battery clip may fall out.

1. Change one side first, then the other.
2. Do not open both ends of the battery clip at the same time.

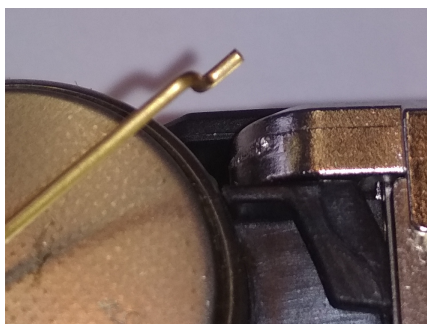

6. Remove the batteries.
7. Insert new batteries.
8. Slide the end of the battery clip back in.
9. Push the end of the battery clip down.
10. Slide the end of the battery clip into the holders provided.
11. Do the same with the other side.

12. Slide the cover back onto the SmartHandle AX.
 13. Press the cover firmly in the area of the recesses for the mounting tool until it snaps into place.
 14. Read off the battery status (see LSM Handbook).
- ↳ Batteries are replaced.

15 Maintenance, cleaning and disinfection

- If necessary, clean the SmartHandle AX with a soft and, if necessary, damp cloth.
- When disinfecting the SmartHandle AX, only use agents that are expressly intended for disinfecting sensitive metal or plastic surfaces.
- If necessary, change the battery.

16 Disassembly

You will also find information on disassembly in the supplied quick guides.

16.1 Variant A0 (vertical)

You need the following tools for disassembly:

- TX-15 screwdriver
- Slotted-head screwdriver
- PH-2 screwdriver
- 1.5 mm hex key

Remove fittings

1. Disassemble electronic cylinders if necessary.
2. Unscrew the headless screws of both handles.
3. If necessary, remove the escutcheon covers with a slotted screwdriver.
4. If necessary, remove the escutcheon covers.
5. If necessary, unscrew the escutcheon bases.
6. Remove the inlay of the inside handle with a slotted screwdriver.
7. Unscrew the screws of the base of the inside handle.
8. Remove the inside handle.
9. Pull out the assembly with the square.
 - ↳ SmartHandle AX is removed from the door.
10. Push the locking pin of the square inward and pull the square out of the assembly.
 - ↳ The square is removed.

Removing the handle from the assembly

1. Insert the Allen wrench into the hole provided in the square socket.

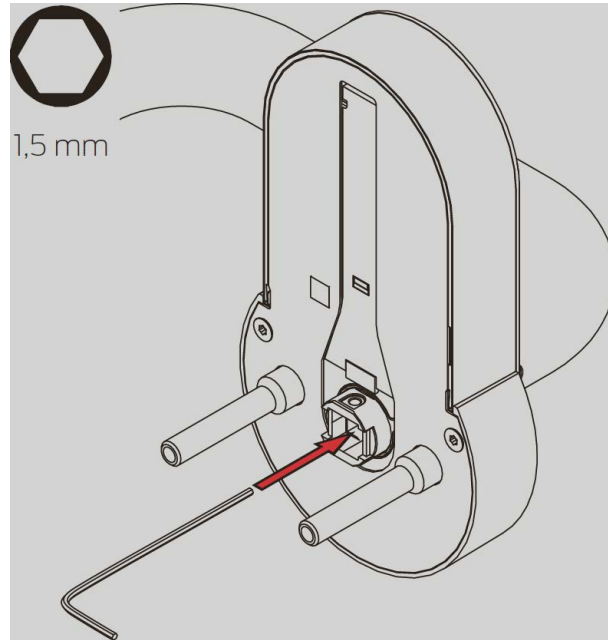

2. Push the Allen wrench towards the nearer edge and hold it pressed.

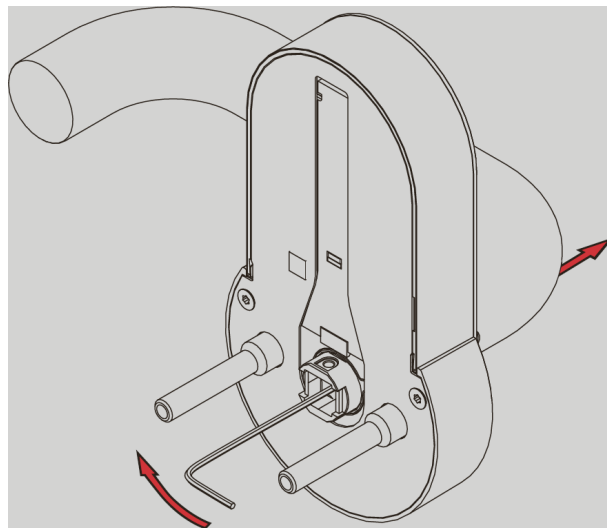

3. Remove the handle from the assembly.
↳ SmartHandle AX is disassembled.

16.2 Variant A1/A2 (suspended short/long)

You need the following tools for disassembly:

- TX-15 screwdriver
- Slotted-head screwdriver
- PH-2 screwdriver

- 1.5 mm hex key

Remove fittings

1. Disassemble electronic cylinders if necessary.
2. Unscrew the headless screws of both handles.
3. If necessary, remove the escutcheon covers with a slotted screwdriver.
4. If necessary, remove the escutcheon covers.
5. If necessary, unscrew the escutcheon bases.
6. Remove the inlay of the inside handle with a slotted screwdriver.
7. Unscrew the screws of the base of the inside handle.
8. Remove the inside handle.
9. Pull out the assembly with the square.
 - ↳ SmartHandle AX is removed from the door.
10. Push the locking pin of the square inward and pull the square out of the assembly.
 - ↳ The square is removed.

Removing the handle from the assembly

1. Insert the Allen wrench into the hole provided in the square socket.

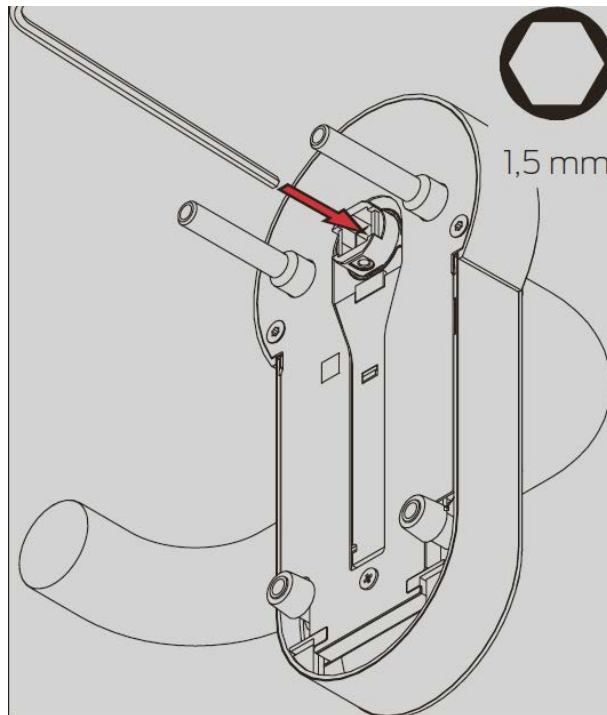

2. Push the Allen wrench towards the nearer edge and hold it pressed.

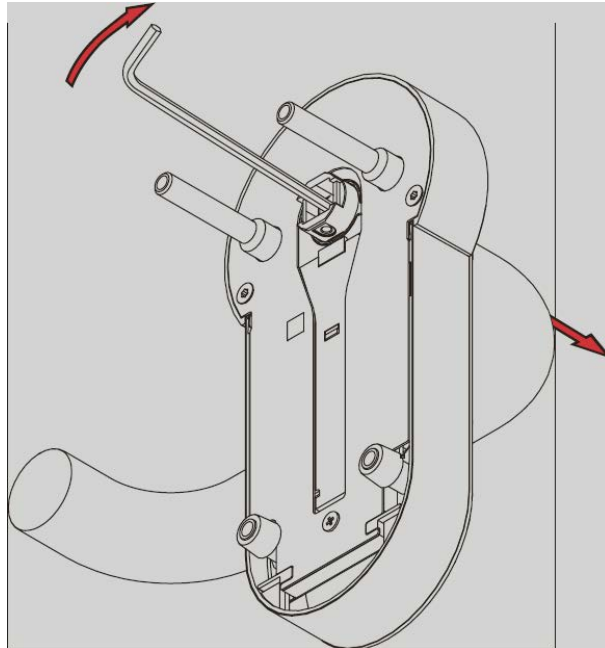

3. Remove the handle from the assembly.
↳ SmartHandle AX is disassembled.

16.3 Variant A3 (steel frame)

Remove fittings

1. Disassemble electronic cylinders if necessary.
2. Unscrew the headless screws of both handles.
3. If necessary, remove the escutcheon covers with a slotted screwdriver.
4. If necessary, remove the escutcheon covers.
5. If necessary, unscrew the escutcheon bases.
6. Remove the inlay of the inside handle with a slotted screwdriver.
7. Unscrew the screws of the base of the inside handle.
8. Remove the inside handle.
9. Take off the cover.
10. Unscrew the small screw at the round end.
11. Slide the assembly upwards.
12. Pull the assembly with the square end out of the adapter plate.
13. Unscrew the adapter plate.
↳ SmartHandle AX is removed from the door.
14. Push the locking pin of the square inward and pull the square out of the assembly.

Removing the handle from the assembly

1. Insert the Allen wrench into the hole provided in the square socket.

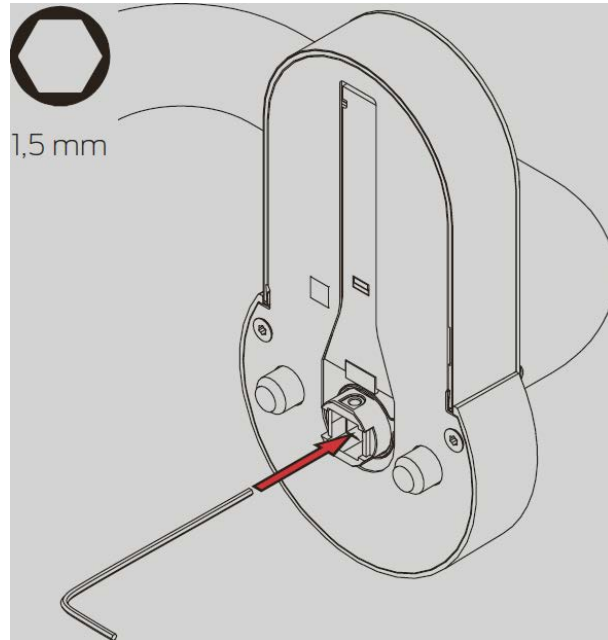

2. Push the Allen wrench towards the nearer edge and hold it pressed.

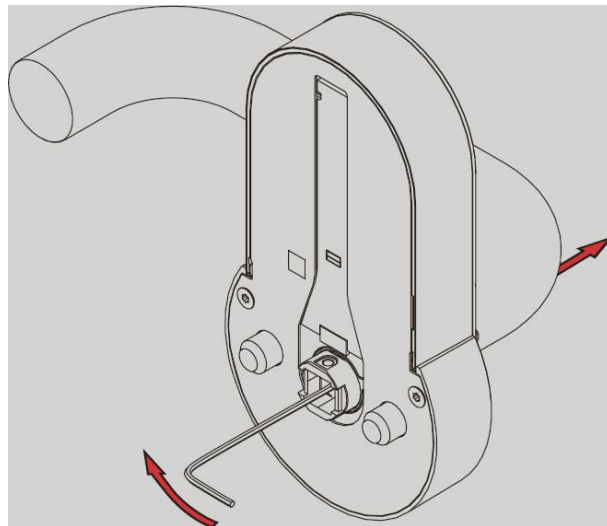

3. Remove the handle from the assembly.
↳ SmartHandle AX is disassembled.

16.4 Variant A4 (Panic bar)

16.4.1 BKS

Remove fittings

1. Remove the panic bar as described in the manufacturer's documentation except for the adapter plate.

**NOTE****Third party product with own documentation**

The panic bar holder is a third-party product.

■ Please follow the manufacturer's instructions and safety instructions.

2. Remove the covers of the escutcheons with a slotted screwdriver.
3. Unscrew the screws of the escutcheon bases.
4. Unscrew the screws of the mounting plate.
5. Pull out the fitting with the adapter plate and the square.
 - ↳ SmartHandle AX is removed from the door.
6. Unscrew the screws that fix the SmartHandle AX to the adapter plate.
 - ↳ Adapter plate is removed.
7. Push the locking pin of the square inward and pull the square out of the assembly.
 - ↳ The square is removed.

Removing the handle from the assembly

1. Insert the Allen wrench into the hole provided in the square socket.

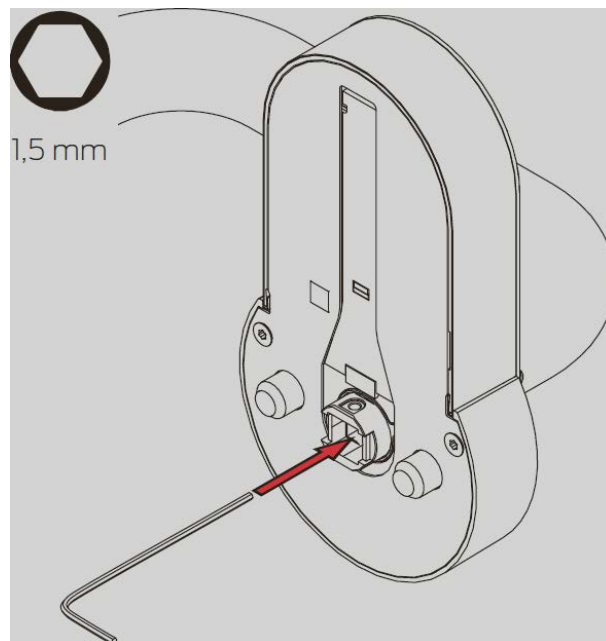

2. Push the Allen wrench towards the nearer edge and hold it pressed.

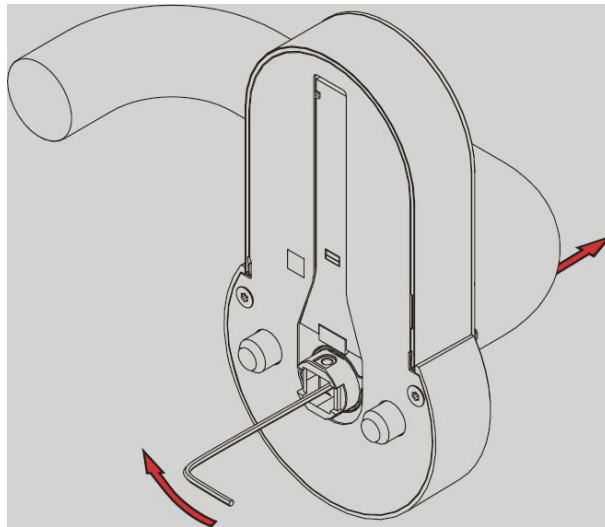

3. Remove the handle from the assembly.
↳ SmartHandle AX is disassembled.

16.4.2 CISA

1. Remove the panic bar as described in the manufacturer's documentation except for the adapter plate.



NOTE

Third party product with own documentation

The panic bar holder is a third-party product.

- Please follow the manufacturer's instructions and safety instructions.
2. Unscrew the screws of the mounting plate.
 3. Pull out the fitting with the adapter plate and the square.
↳ SmartHandle AX is removed from the door.
 4. Unscrew the screws that fix the SmartHandle AX to the adapter plate.
↳ Adapter plate is removed.
 5. Push the locking pin of the square inward and pull the square out of the assembly.
↳ The square is removed.

Removing the handle from the assembly

1. Insert the Allen wrench into the hole provided in the square socket.

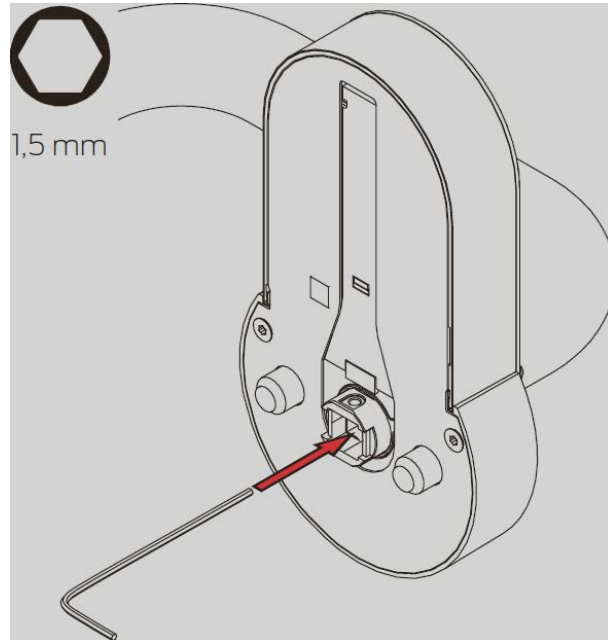

2. Push the Allen wrench towards the nearer edge and hold it pressed.

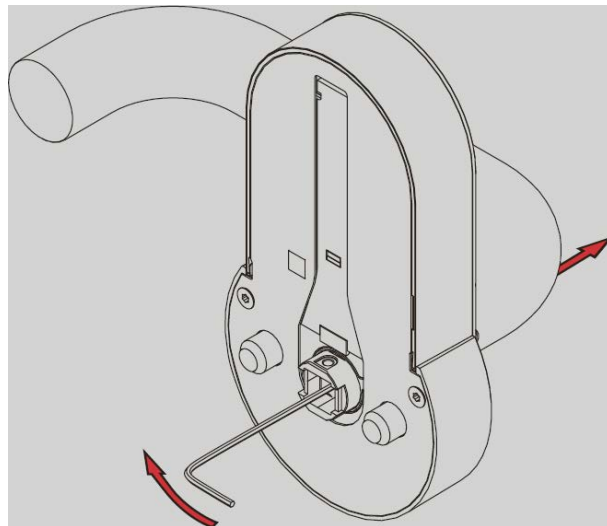

3. Remove the handle from the assembly.
↳ SmartHandle AX is disassembled.

16.5 DS variant (reader on both sides)

Remove fittings

1. Disassemble electronic cylinders if necessary.
2. Unscrew the set screws of both handles.
3. If necessary, remove the escutcheon covers with a slotted screwdriver.
4. If necessary, remove the escutcheon covers.

5. If necessary, unscrew the escutcheon bases.
6. Remove the cover of the SmartHandles AX that is attached to the adapter plate.
7. Unscrew the screw above the card reader.
8. Turn the entire SmartHandle AX clockwise until it can be removed.
9. Remove the SmartHandle AX.
10. Unscrew the adapter plate.
11. Pull out the second SmartHandle AX.
 - ↳ SmartHandle AX are removed from the door.
12. Push the locking pin of the square inward and pull the square out of the assembly.

Removing the handle from the assembly

1. Insert the Allen wrench into the hole provided in the square socket.

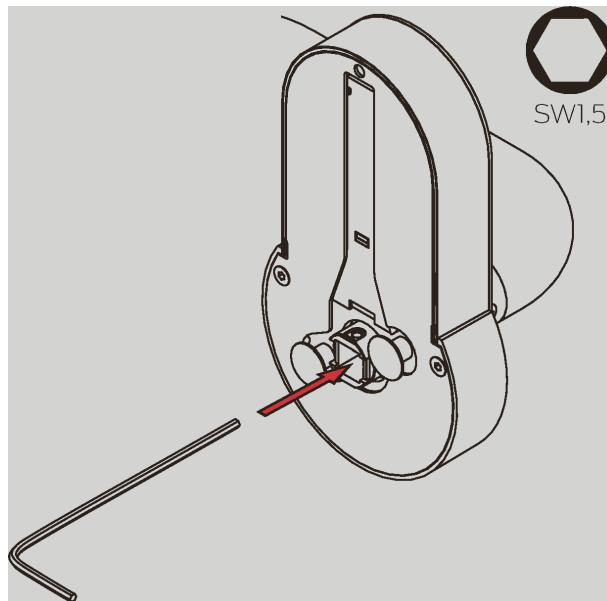

2. Push the Allen wrench towards the nearer edge and hold it pressed.

3. Remove the handle from the assembly.

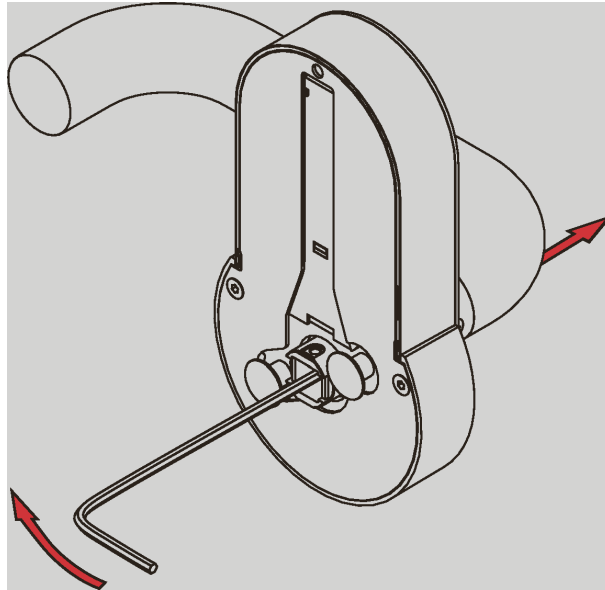

↳ SmartHandle AX is disassembled.

16.6 Variant E0 and E1 (Scandinavian Oval)

You need the following tools for disassembly:

- TX-15 screwdriver
- Slotted-head screwdriver
- PH-2 screwdriver
- 1.5 mm hex key

Remove fittings

1. Disassemble electronic cylinders if necessary.
2. Unscrew the headless screws of both handles.
3. If necessary, remove the escutcheon covers with a slotted screwdriver.
4. If necessary, remove the escutcheon covers.
5. If necessary, unscrew the escutcheon bases.
6. Remove the inlay of the inside handle with a slotted screwdriver.
7. Unscrew the screws of the base of the inside handle.
8. Remove the inside handle.
9. Pull out the assembly with the square.
 - ↳ SmartHandle AX is removed from the door.
10. Push the locking pin of the square inward and pull the square out of the assembly.
 - ↳ The square is removed.

Removing the handle from the assembly

1. Insert the Allen wrench into the hole provided in the square socket.

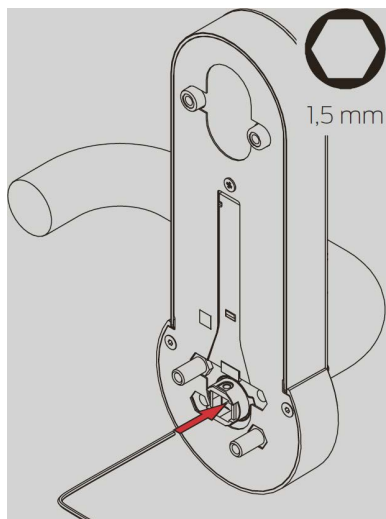

2. Push the Allen wrench towards the nearer edge and hold it pressed.

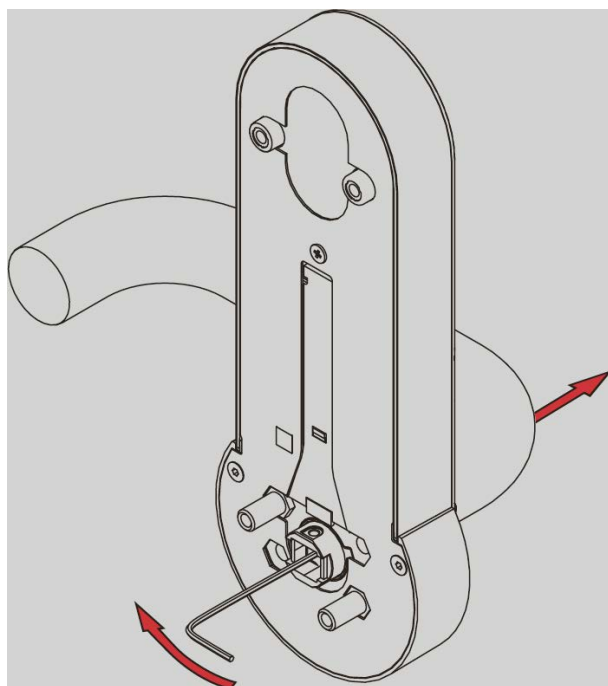

3. Remove the handle from the assembly.
↳ SmartHandle AX is disassembled.

17 Accessories

Networking

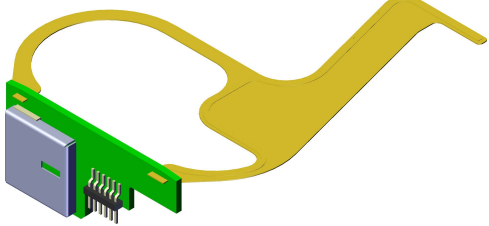
Order code	Description
WNM.LNI.S2	<p>In your SmartHandle AX integratable LockNode for direct networking (with auto-configuration).</p>  <p>Also see <i>Network</i> [▶ 16] and <i>Lock-Node (LNI)</i> [▶ 145].</p>

Third party handle adapter

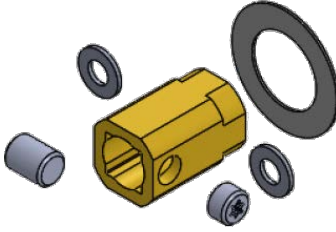
Order code	Description	Compatibility
S2.ADAPTER.FSB	<p>Adapter set for FSB brand lever handles (www.fsb.de) from FSB model year 2018 upwards</p> 	<p>All FSB models from 2018 with one of the following mounting types:</p> <ul style="list-style-type: none"> ■ Standard (FSB ASL®) ■ Object (FSB AGL®)
S2.ADAPTER.GLUTZ	<p>Adapter set for Glutz brand lever handles (www.glutz.com)</p>	<ul style="list-style-type: none"> ■ 5083 Tulln ■ Others on request / after qualification.

Handle and square

Order code	Description
S2.LEVER.x.x	<p>Handle interior and exterior for post-fitting (see <i>Handle variants</i> [▶ 16]).</p> <p>Please indicate variant:</p> <ul style="list-style-type: none"> ■ A ■ B ■ C ■ D ■ L <p>Please specify square (see <i>Spindle</i> [▶ 15]):</p> <ul style="list-style-type: none"> ■ 7 mm ■ 8 mm ■ 9 mm
S2.SQUARE.x.x	<p>Square, please specify length (see <i>Distances and door thicknesses</i> [▶ 14]):</p> <ul style="list-style-type: none"> ■ S ■ M ■ L ■ X <p>Please specify diameter (siehe <i>Spindle</i> [▶ 15]):</p> <ul style="list-style-type: none"> ■ 7 mm ■ 8 mm ■ 9 mm
SH.SLEEVES.8.5	<p>Extension sleeve from 8 mm to 8.5 mm in length (10 units)</p>

Cover



Order code	Description
S2.COVER.0.SG	Cover for variant A0/B0 (stationary), RR (metal frame) and DS (both sides) in black-grey
S2.COVER.0.W	Cover for variant A0/B0 (stationary), RR (metal frame) and DS (both sides) in white
S2.COVER.1.SG	Cover for variant A1/B1 (suspended short) in black-grey
S2.COVER.1.W	Cover for variant A1/B1 (suspended short) in white
S2.COVER.2.SG	Cover for variant A2/B2 (suspended long) in black-grey
S2.COVER.2.W	Cover for variant A2/B2 (suspended long) in white
S2.COVER.E0.SG	Cover for variant E0 (Scandinavian oval without locking cylinder cut-out) in black-grey
S2.COVER.E0.W	Cover for variant E0 (Scandinavian oval without locking cylinder cut-out) in white
S2.COVER.E1.SG	Cover for variant E1 (Scandinavian oval with locking cylinder cut-out) in black-grey
S2.COVER.E1.W	Cover for variant E1 (Scandinavian oval with locking cylinder cut-out) in white

Small parts

Order code	Description
S2.SLEEVENUT	Sleeve nut for escutcheon (50 pieces)
S2.SCREW.x	Screw set, please specify length (see <i>Distances and door thicknesses</i> [▶ 14]): <ul style="list-style-type: none"> ■ S ■ M ■ L ■ X
S2.COMPSHELL	Compensating bushes for the variants A0/B0 (10 bags with 2x3 pieces each in three different lengths)

Escutcheon

Order code	Description
S2.ROSE	Escutcheon cover without locking cylinder opening, for retrofit
S2.ROSEPZ	Escutcheon cover with locking cylinder opening for Euro profile cylinder for retrofitting
S2.ROSESO	Escutcheon cover with locking cylinder opening for Scandinavian Oval Cylinders for retrofitting

Dummy cylinders

Order code	Description
DUMMY CYLINDER.PZ	Dummy cylinder (15-15 mm) for filling the locking cylinder opening (Euro profile cylinder)
DUMMY CYLINDER.SR	Dummy cylinder (15-15 mm) for filling the locking cylinder opening (Swiss-Round cylinder)

18 Technical specifications

18.1 Electronics

Read systems	<ul style="list-style-type: none"> ■ Active ■ Passive 	
Read ranges	Active	5 cm to 30 cm
	Passive	Close range
Power supply		
Battery type	4× CR2450 (3 V)	
Battery manufacturer	<ul style="list-style-type: none"> ■ Murata ■ Varta ■ Panasonic 	
Battery life	<ul style="list-style-type: none"> ■ Up to 300000 operations (active) ■ Up to 200000 operations (passive) ■ Up to 10 years stand-by without operation 	
Battery life with LockNode	tba	
Ambient conditions		
Temperature range	Operational: -25 °C to +50 °C	
	In storage (temporary): -40 °C to +50 °C	
	In storage (long-term): 0 °C to +30 °C	
Protection rating	IP40	
Feedback		
Signalling	<ul style="list-style-type: none"> ■ Acoustic (beeper) ■ Optical (two-colour LED) 	
Administration and settings		
Loggable access events	Max. 3000	
Time zone groups	100+1	
Max. transponders per SH AX	Max. 64000	
Max. SmartCards per SH AX	max. 64000 (depending on card configuration)	
Coupling time	<ul style="list-style-type: none"> ■ Impulse power: 1 s to 25 s ■ Flipflop 	

Networking capability	Retrofittable LockNode	
Other information		
Can be upgraded	Upgradeable firmware	
Handle operating angle	48° effective	
Colours	Cover	<ul style="list-style-type: none"> ■ Traffic white (RAL 9016) ■ Dark grey (RAL 7021)
	Escutcheon	Brushed nickel, lacquered
	Handle	Stainless steel, brushed

Radio emissions		
SRD	15.25 kHz - 72.03 kHz	10 dB μ A/m (3 m distance)
RFID	13.560006 MHz - 13.560780 MHz	1.04 dB μ A/m (3 m distance)
BLE (depending on equipment)	2402 MHz - 2480 MHz	2.5 mW
SRD (WaveNet) (depending on equipment)	868.000 MHz - 868.600 MHz	<25 mW ERP

There are no geographical restrictions within the EU.

18.2 Mechanical system

Dimensions

The dimensions refer to the side with the electronic fitting.

Height	<ul style="list-style-type: none"> ■ A0 (stationary) ■ A3 (metal frame) ■ DS (reader on both sides) 	120 mm
	A1 (suspended short)	140 mm
	<ul style="list-style-type: none"> ■ A2 (suspended long) ■ E0/E1 (Scandinavian Oval) 	174 mm
	A4 (panic bar)	<ul style="list-style-type: none"> ■ BKS (distance: 72 mm): 193.4 mm ■ BKS (distance: 92 mm): 213.4 mm ■ CISA (distance: 72 mm): 224.4 mm (Specifications with adapter plate)
Width	66 mm	
Depth	<ul style="list-style-type: none"> ■ A0 (stationary) ■ A1 (suspended short) ■ A2 (suspended long) ■ E0/E1 (Scandinavian Oval) 	21 mm
	A3 (metal frame)	26 mm (Specifications with adapter plate)
	A4 (panic bar)	25 mm (Specifications with adapter plate)
	DS (reader on both sides)	<ul style="list-style-type: none"> ■ 21 mm (side without adapter plate) ■ 26 mm (side with adapter plate)

Available detailed dimensional drawings can be found at the end of the chapter.

Distances and door thicknesses

A* = Euro profile, B* = Swiss round, E* = Scandinavian Oval

Versions	Centres distance	Door thickness
A0/B0 Stationary	not relevant (stationary installation: Handle shaft axis and profile cylinder axis not connected at the fitting)	S: 38 - 60 mm
		M: 59 - 80 mm
		L: 79 - 100 mm
		X: 100-200 mm
A1/B1 Suspended, short	70 - 79 mm	S: 38 - 60 mm
		M: 59 - 80 mm
		L: 79 - 100 mm
		X: 100-200 mm
A2/B2 Suspended, long	70 - 110 mm	S: 38 - 60 mm
		M: 59 - 80 mm
		L: 79 - 100 mm
		X: 100-200 mm
A3 Metal frames	not relevant (stationary installation: Handle shaft axis and profile cylinder axis not connected at the fitting)	S: 38 - 57 mm
		M: 58 - 77 mm
		L: 78 - 97 mm
		X: 97 - 196 mm
A4 Panic bar	92 mm (BKS full-leaf door without plate) 72 mm (CISA full-leaf door, with plate or BKS full-leaf door without sign)	S: 38 - 60 mm
		M: 59 - 80 mm
		L: 79 - 100 mm
		X: 100-200 mm
DS Reader on both sides (double-sided)	not relevant (stationary installation: Handle shaft axis and profile cylinder axis not connected at the fitting)	S: 38 - 58 mm
		M: 59 - 78 mm
		L: 79 - 99 mm
		X: 100-200 mm

Versions	Centres distance	Door thickness
E0, E1 Scandinavian Oval	105 mm	S: 38 - 60 mm
		M: 59 - 80 mm
		L: 79 - 100 mm
		X: 100 - 200 mm

Handle turning angle and colours

Handle turning angle		48° effective
Colours	Cover	<ul style="list-style-type: none"> ■ Traffic white (RAL 9016) ■ Dark grey (RAL 7021) ■ Brass For colours of the covers see also <i>Surface finishes</i> [▶ 17]
	Escutcheon	<ul style="list-style-type: none"> ■ Brushed nickel, coated ■ Brushed Brass, coated
	Handle	<ul style="list-style-type: none"> ■ Brushed stainless steel, coated ■ Brushed Brass, coated

18.2.1 Dimensional drawings SmartHandle AX



NOTE

Height depends on the variant (see table).

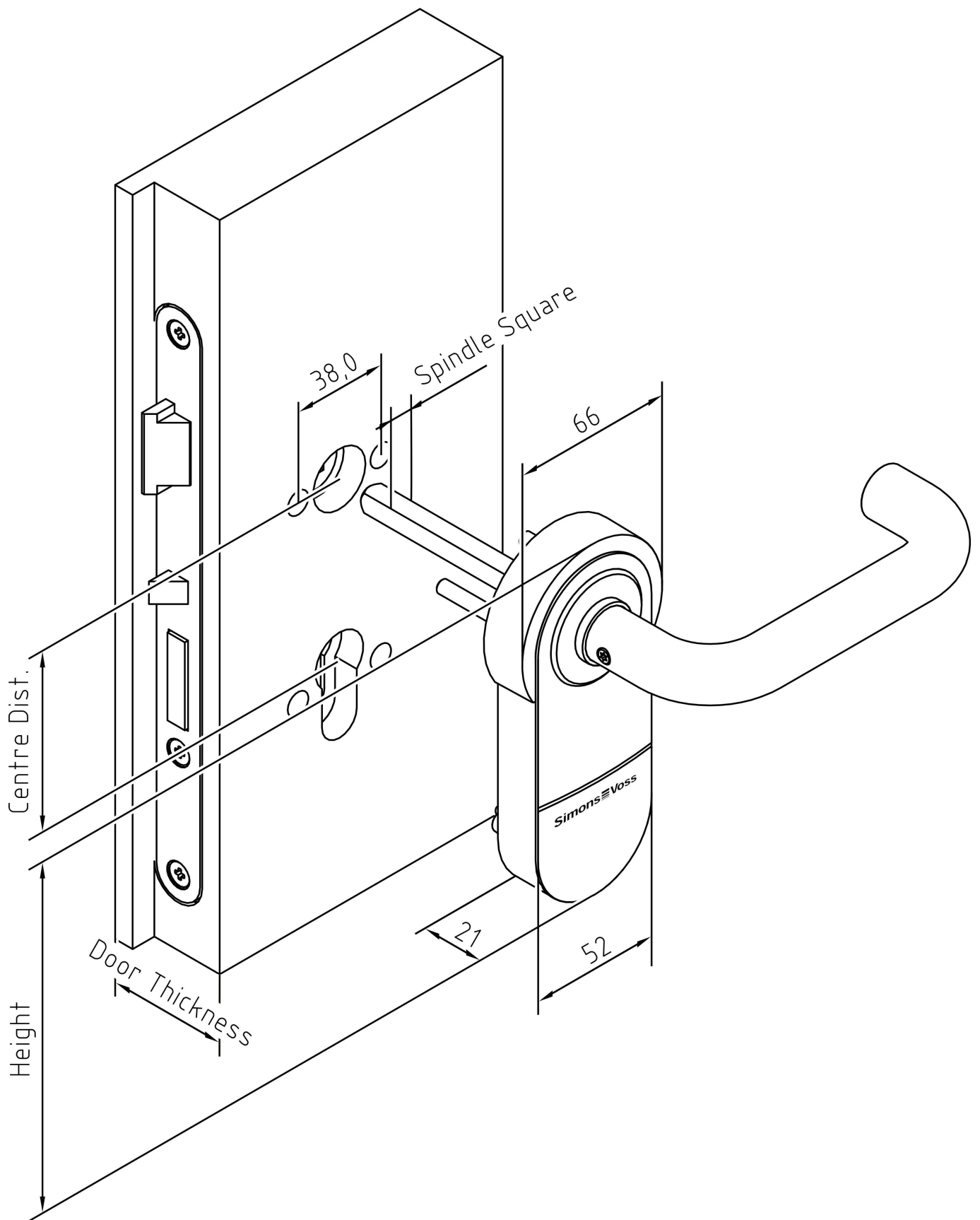

Fig. 9: Dimensioning SmartHandle AX suspended (A1, A2)

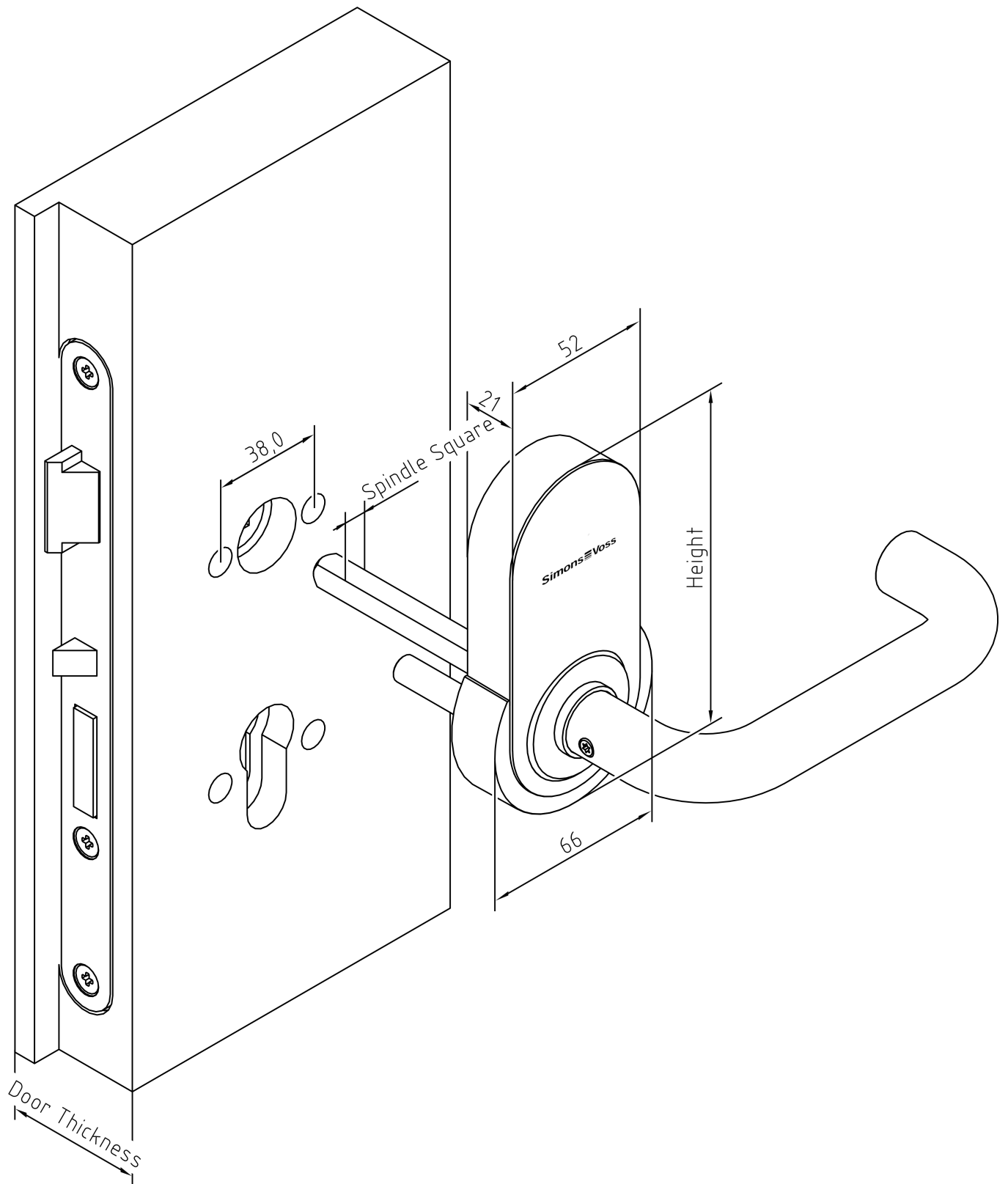

Fig. 10: Dimensioning SmartHandle AX stationary (A0)

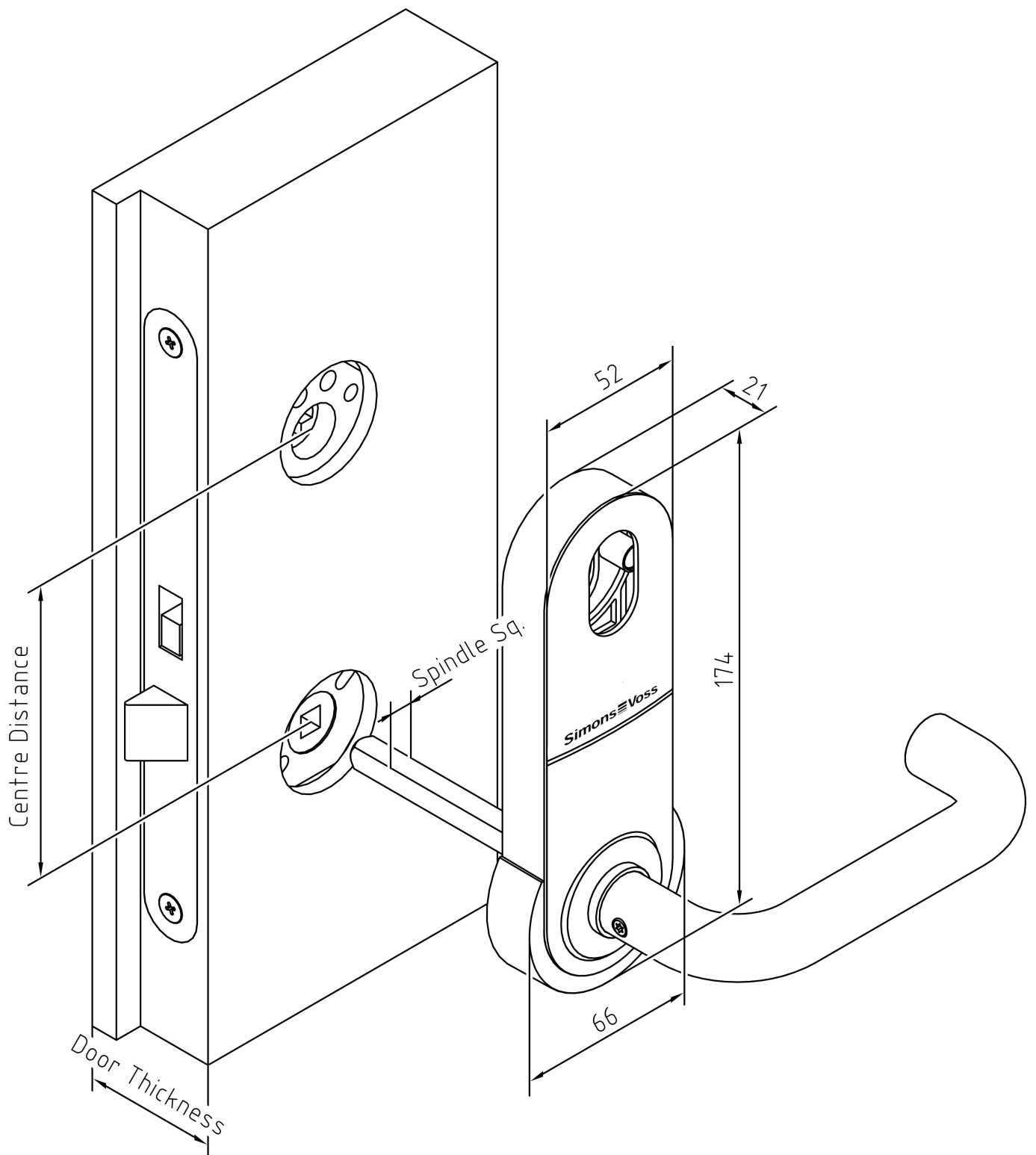

Fig. 11: Dimensioning SmartHandle AX Scandinavian Oval (E0, E1)

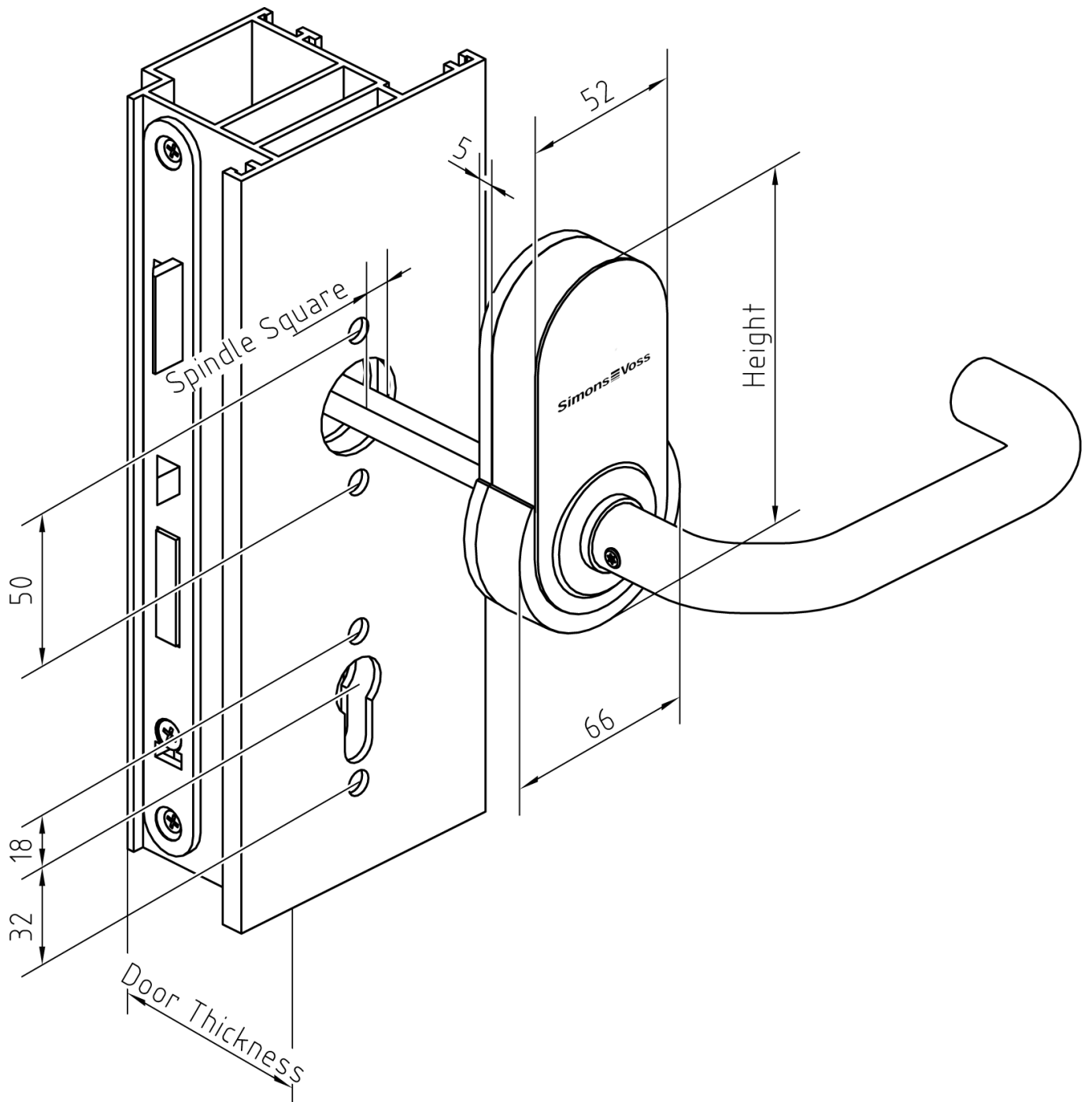

Fig. 12: Dimensioning SmartHandle AX metal frame (A3)

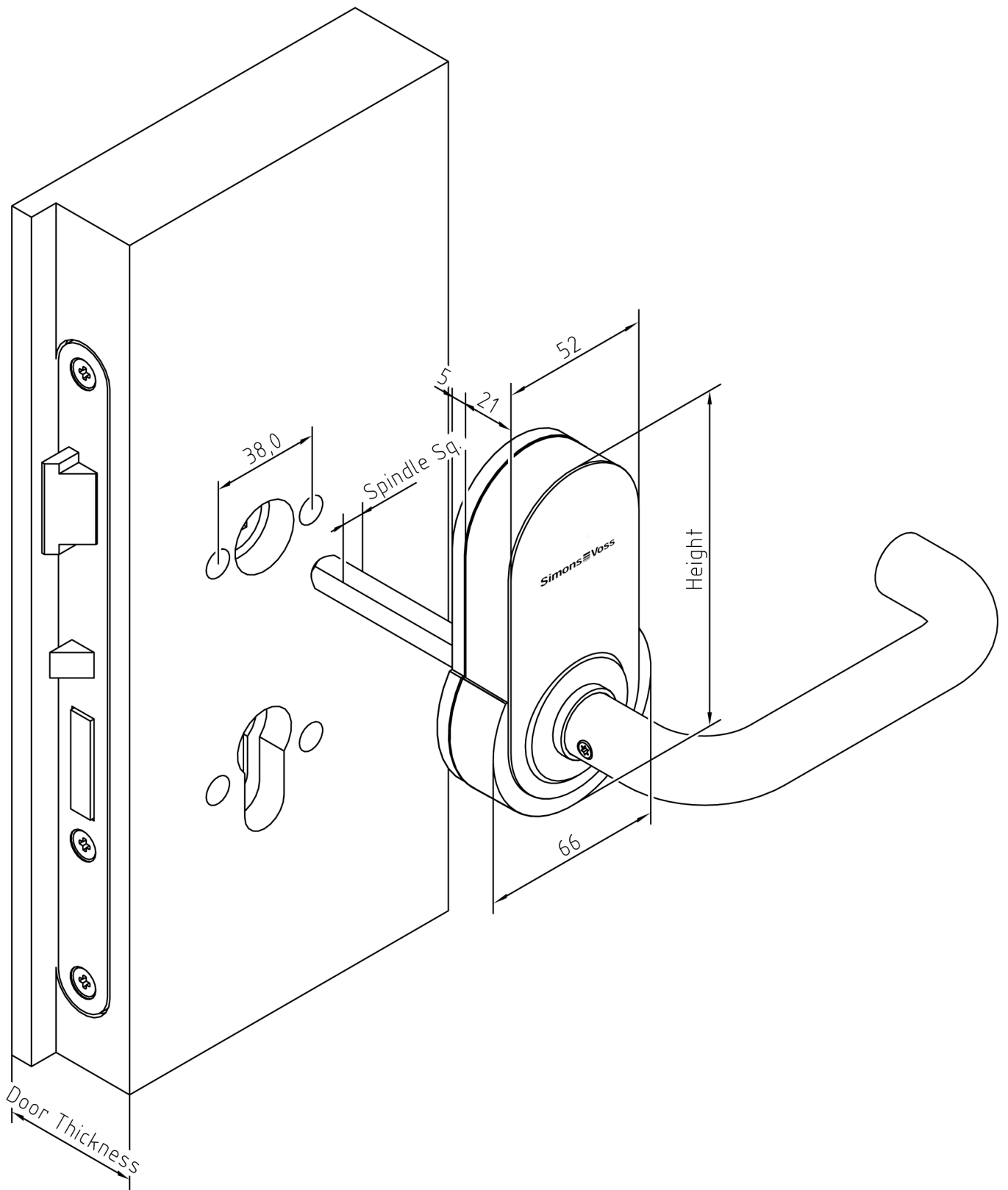
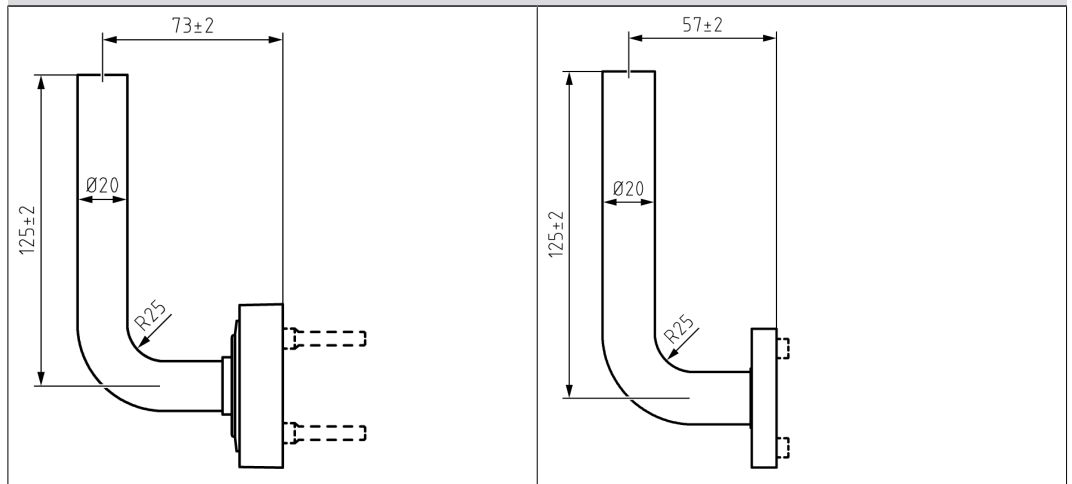

Fig. 13: Dimensioning SmartHandle AX BSL (DS)

18.2.2 Dimensional drawings handles

Shape A (Outside/Inside)



Shape B (Outside/Inside)

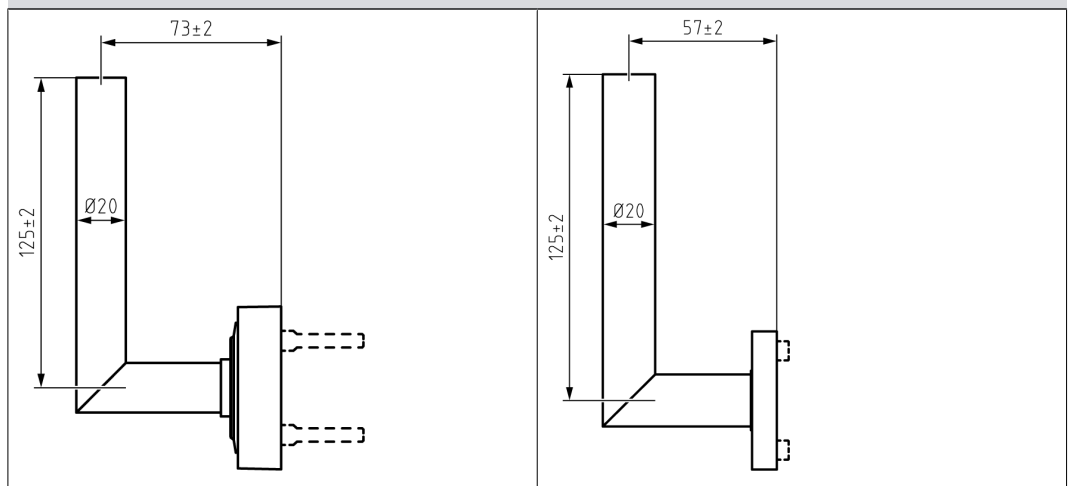

Shape C (Outside/Inside)

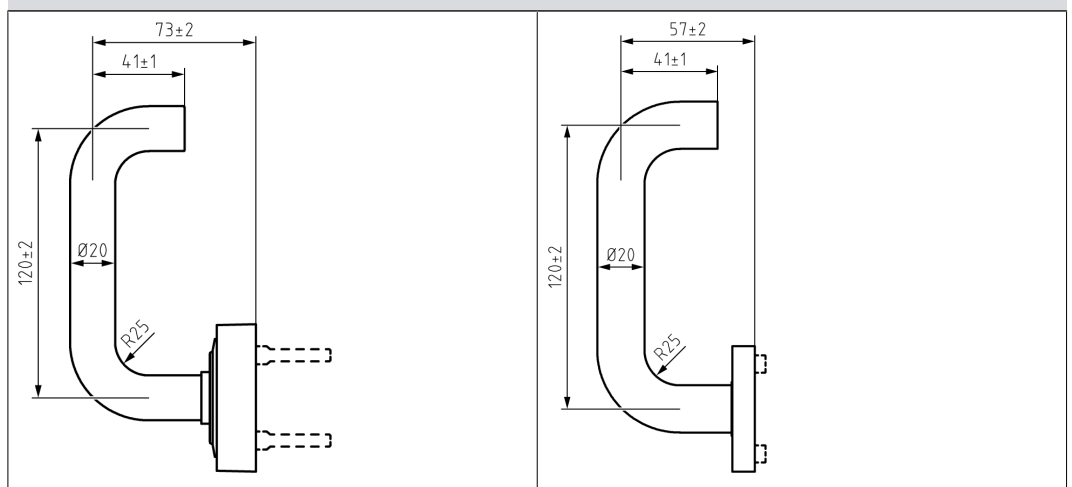

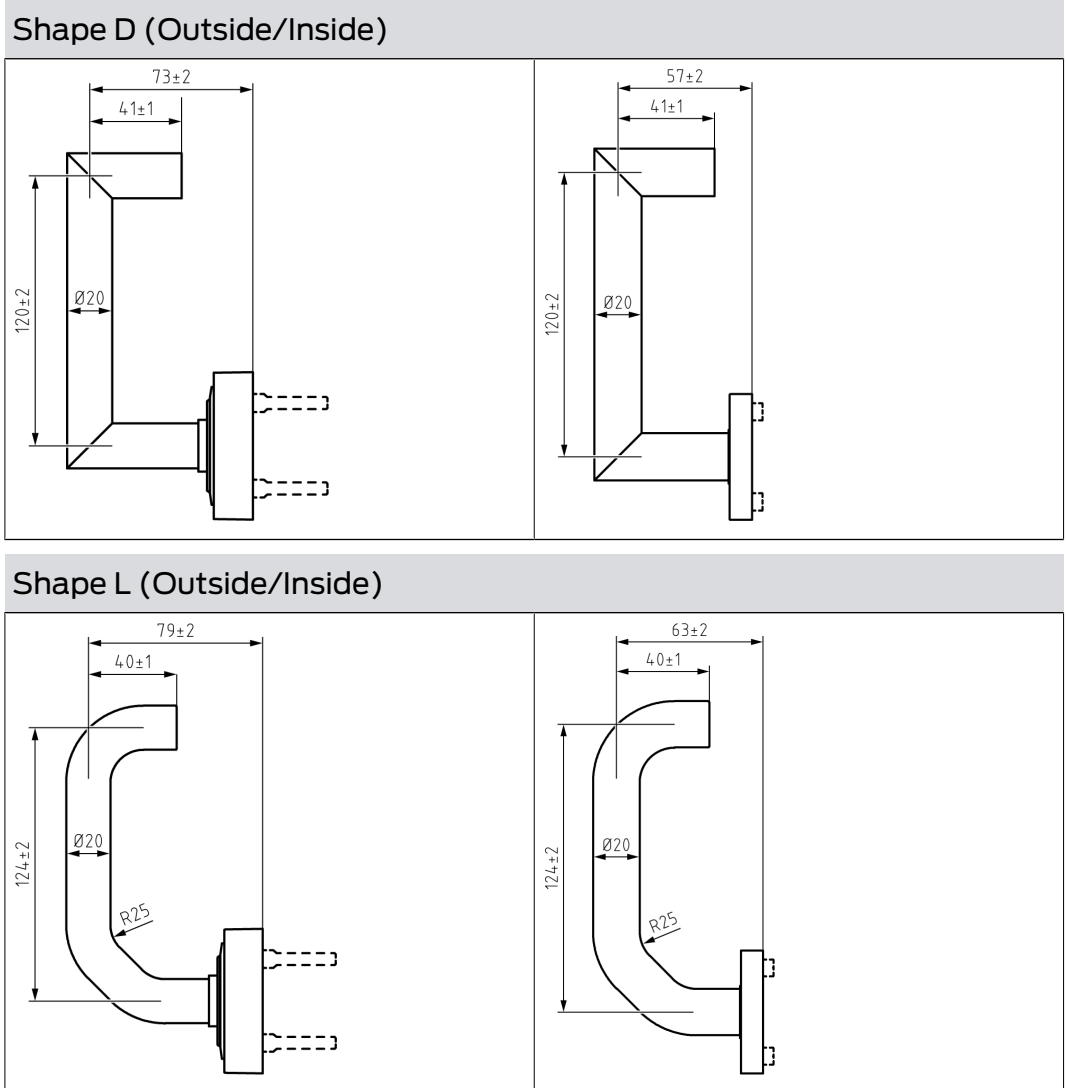

18.3 Configuration

Administration and settings

Loggable access events	Max. 1500
Time zone groups	100+1
Max. transponders per SH AX	Max. 64000
Max. SmartCards per SH AX	max. 64000 (depending on card configuration)
Coupling time	<ul style="list-style-type: none"> ■ Impulse power: 1 s to 25 s ■ Flipflop
Networking capability	Retrofittable LockNode

Other information

Can be upgraded	Upgradeable firmware
-----------------	----------------------

19 EU/UK Declaration of conformity

The company SimonsVoss Technologies GmbH hereby declares that article SI.S2.*, S2.* complies with the following guidelines:

- 2014/53/EU "Radio equipment"
as well as the corresponding UK statutory 2017 No. 1206 "Radio equipment"
- 2014/30/EU "EMC"
as well as the corresponding UK statutory 2016 No. 1091 "EMC"
- 2012/19/EU "WEEE"
as well as the corresponding UK statutory 2013/3113 "WEEE"
- 2011/65/EU "RoHS"
as well as the corresponding UK statutory 2012 No. 3032 "RoHS"
- and regulation (EG) 1907/2006 "EU REACH"
as well as the corresponding "UK REACH"

The full text of the EU/UK Declaration of conformity is available at the following internet address:

www.simons-voss.com/en/certificates.html



20 Help and other information

Information material/documents

You will find detailed information on operation and configuration and other documents on the website:

www.simons-voss.com/en/documents.html

Declarations of conformity

You will find declarations of conformity and other certificates on the website:

www.simons-voss.com/en/certificates.html

Information on disposal

- Do not dispose the device (SI.S2.*, S2.*) in the household waste. Dispose of it at a collection point for electronic waste as per European Directive 2012/19/EU.
- Recycle defective or used batteries in line with European Directive 2006/66/EC.
- Observe local regulations on separate disposal of batteries.
- Take the packaging to an environmentally responsible recycling point.



Hotline

Our hotline will be happy to help you (landline, costs depend on provider):

+49 (0) 89 / 99 228 333

Email

You may prefer to send us an email.

support-simonsvoss@allegion.com

FAQs

You will find information and help in the FAQ section:

faq.simons-voss.com/otrs/public.pl

Address

SimonsVoss Technologies GmbH
Feringastr. 4
D-85774 Unterfoehring
Germany



This is SimonsVoss

SimonsVoss, the pioneer in remote-controlled, cable-free locking technology provides system solutions with a wide range of products for SOHOs, SMEs, major companies and public institutions. SimonsVoss locking systems combine intelligent functionality, high quality and award-winning design Made in Germany.

As an innovative system provider, SimonsVoss focuses on scalable systems, high security, reliable components, powerful software and simple operation. As such, SimonsVoss is regarded as a technology leader in digital locking systems.

Our commercial success lies in the courage to innovate, sustainable thinking and action, and heartfelt appreciation of employees and partners.

SimonsVoss is a company in the ALLEGION Group, a globally active network in the security sector. Allegion is represented in around 130 countries worldwide (www.allegion.com).

Made in Germany

SimonsVoss is truly committed to Germany as a manufacturing location: all products are developed and produced exclusively in Germany.

© 2021, SimonsVoss Technologies GmbH, Unterföhring

All rights are reserved. Text, images and diagrams are protected under copyright law.

The content of this document must not be copied, distributed or modified. More information about this product can be found on the SimonsVoss website. Subject to technical changes.

SimonsVoss and MobileKey are registered brands belonging to SimonsVoss Technologies GmbH.



SimonsVoss
technologies

Made in Germany